

FR

DE

EN

NL

IT

ES

PL

RU

Cascade 35-115 kW



Notice de montage
Montageanleitung
Assembly Instructions
Montage instructies

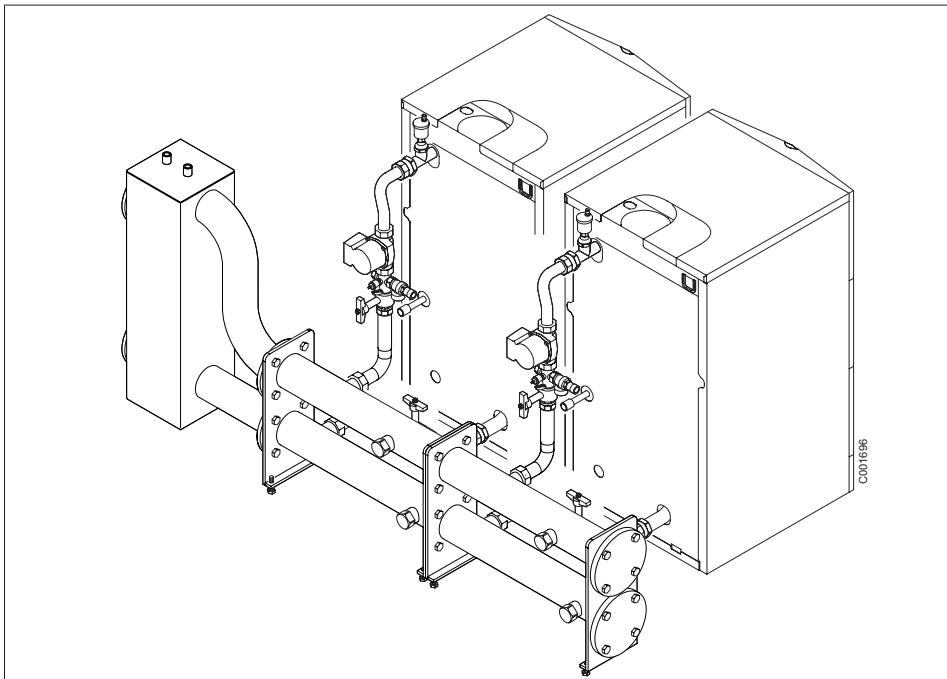

1 Outils nécessaires

1 Benötigtes Werkzeug

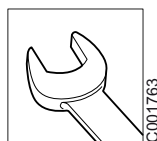

13 - 19 - 24 - 46 - 48 - 50 - 52 - 55

1 Tools required

1 Noodzakelijke gereedschappen en materialen

2 Recommendations

2 Empfehlungen

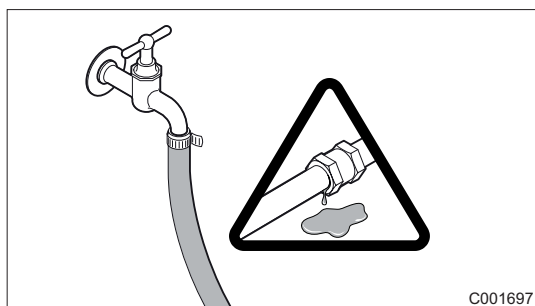
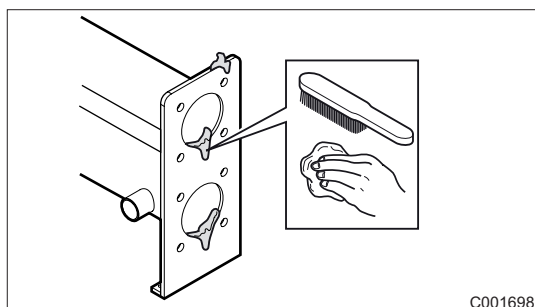
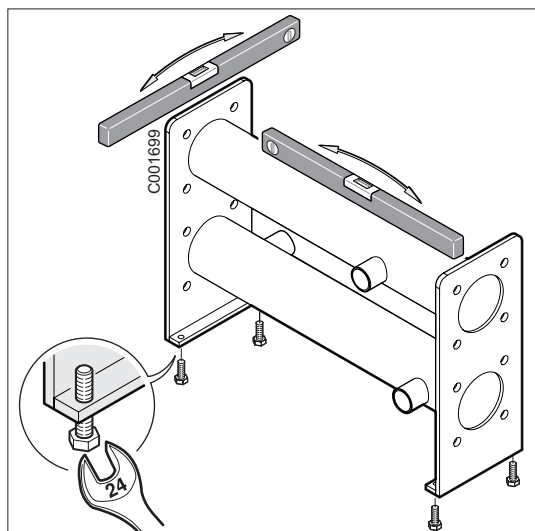

2 Recommendations

2 Aanbevelingen

i Pour le montage des différents composants, utiliser des matériaux d'étanchéité approuvés.

i **Epreuve hydraulique :**
Après le montage des chaudières et du système cascade, il est nécessaire d'effectuer une épreuve hydraulique.

- ▶ Boucher les raccords de départ et de retour.
La pression d'épreuve à l'eau froide doit être de 1.3 x la pression de service.

i Zur Montage der verschiedenen Komponenten zugelassene Dichtmaterialien verwenden.

i **Hydraulischer Drucktest:**
Nach der Montage der Heizkessel und des Kaskadensystems muss eine Hydraulikprüfung durchgeführt werden.

- ▶ Vor- und Rücklaufanschlüsse verstopfen.
Der Prüfdruck bei Kaltwasser muss 1.3 x den Betriebsdruck betragen.

i Preferably approved sealing material should be used.

i **Hydraulic test:**
After assembling the boilers and the cascade system, a pressure-test will visualise water tightness of the cascade system.

- ▶ Flow and return connections must be blanked off.
Apply a cold water pressure of 1.3 x working pressure.

i Gebruik voor de montage van de verschillende onderdelen goedgekeurd afdichtingsmateriaal.

i **Waterdrukproef:**
Na de montage van de verwarmingsketels en het cascadesysteem moet er een hydraulische test uitgevoerd worden.

- ▶ Sluit de aansluitingen van de vertrek- en retourleiding af.
De beproevingsdruk met koud water moet 1.3 x de bedrijfsdruk zijn.

3 Colisage

3 Liefereinheiten

3 Package list

3 Leveringsomvang

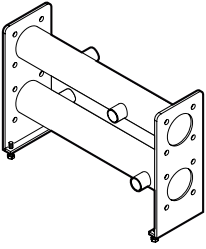
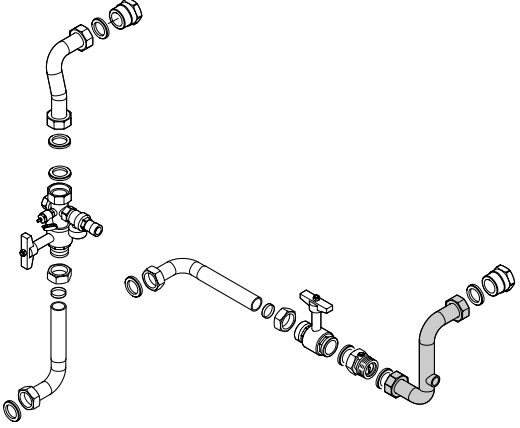
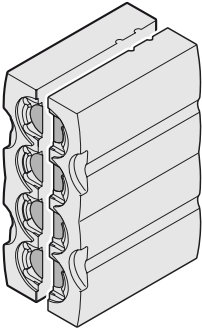
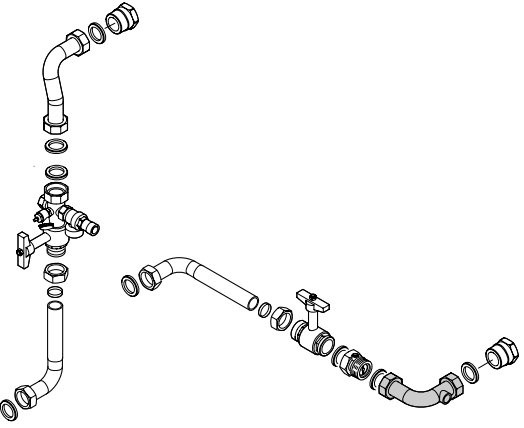
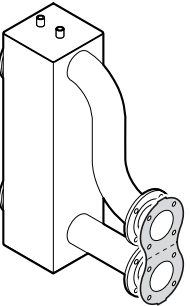
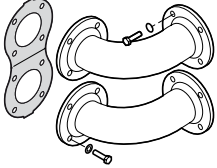
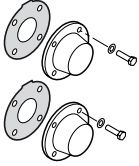
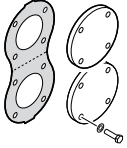
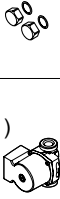
<p>DN65 : 100011703 DN100 : 100011492</p> 	<p>100011491</p> 			
<p>111067</p> 	<p>100011490</p> 			
<p>DN65 : 111712 DN100 : 111714</p> 	<p>DN65 : 111788 DN100 : 111790</p> 	<p>DN65 : 112632 DN100 : 112633</p> 	<p>DN65 : 111701 DN100 : 111703</p> 	<p>111708</p> 

C001605

(1) Pompe à commander en fonction de la puissance de la chaudière.

(1) Pump to be ordered according to the output of the boiler.

(1) Pumpe je nach Leistung des Heizkessels bestellen.

(1) Pomp die bediend wordt aan de hand van het vermogen van de verwarmingsketel.

4 Combinaisons possibles

4 Mögliche Kombinationen

4 Combinations possible

4 Mogelijke combinaties

4.1 LV

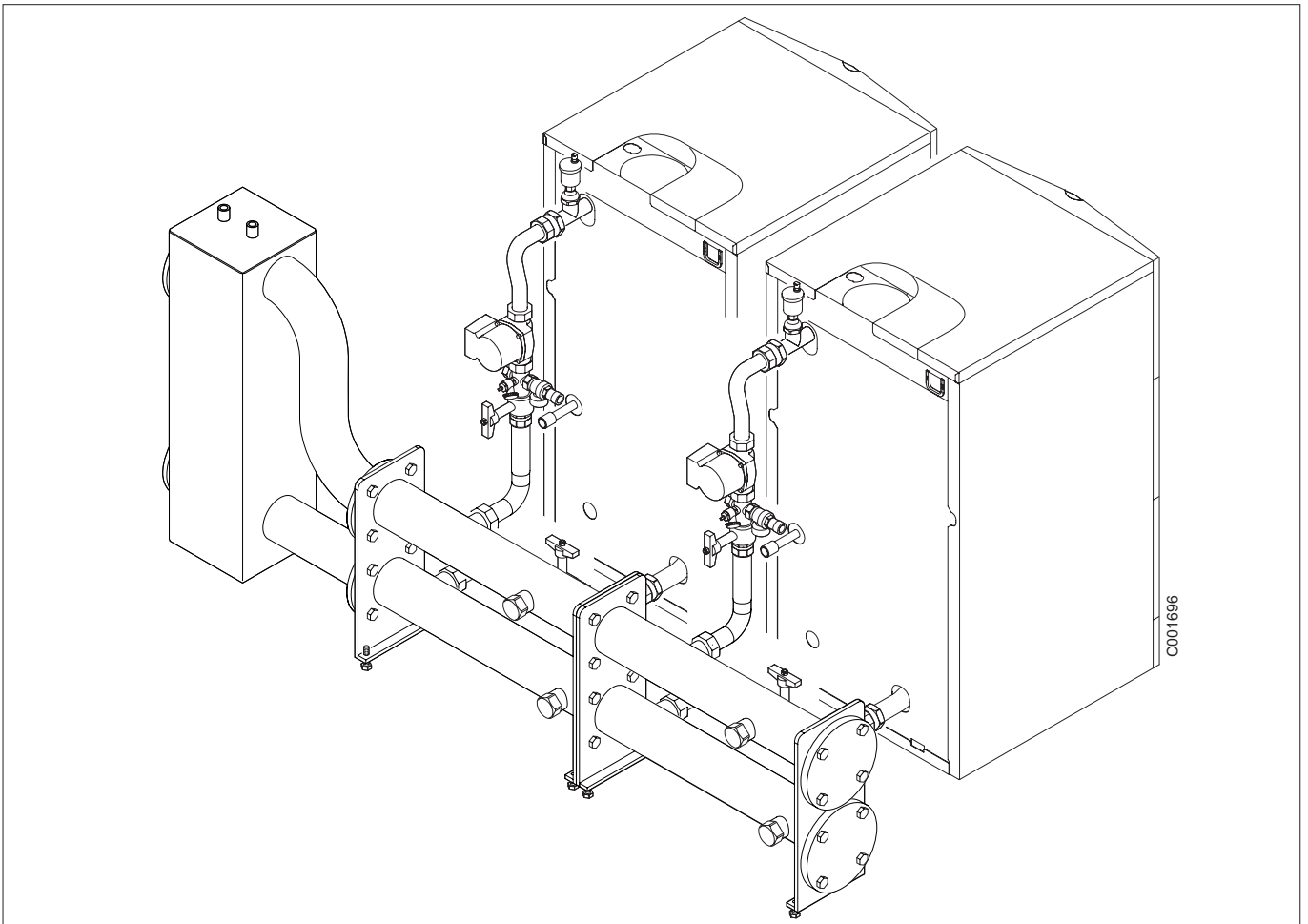

4.2 RG

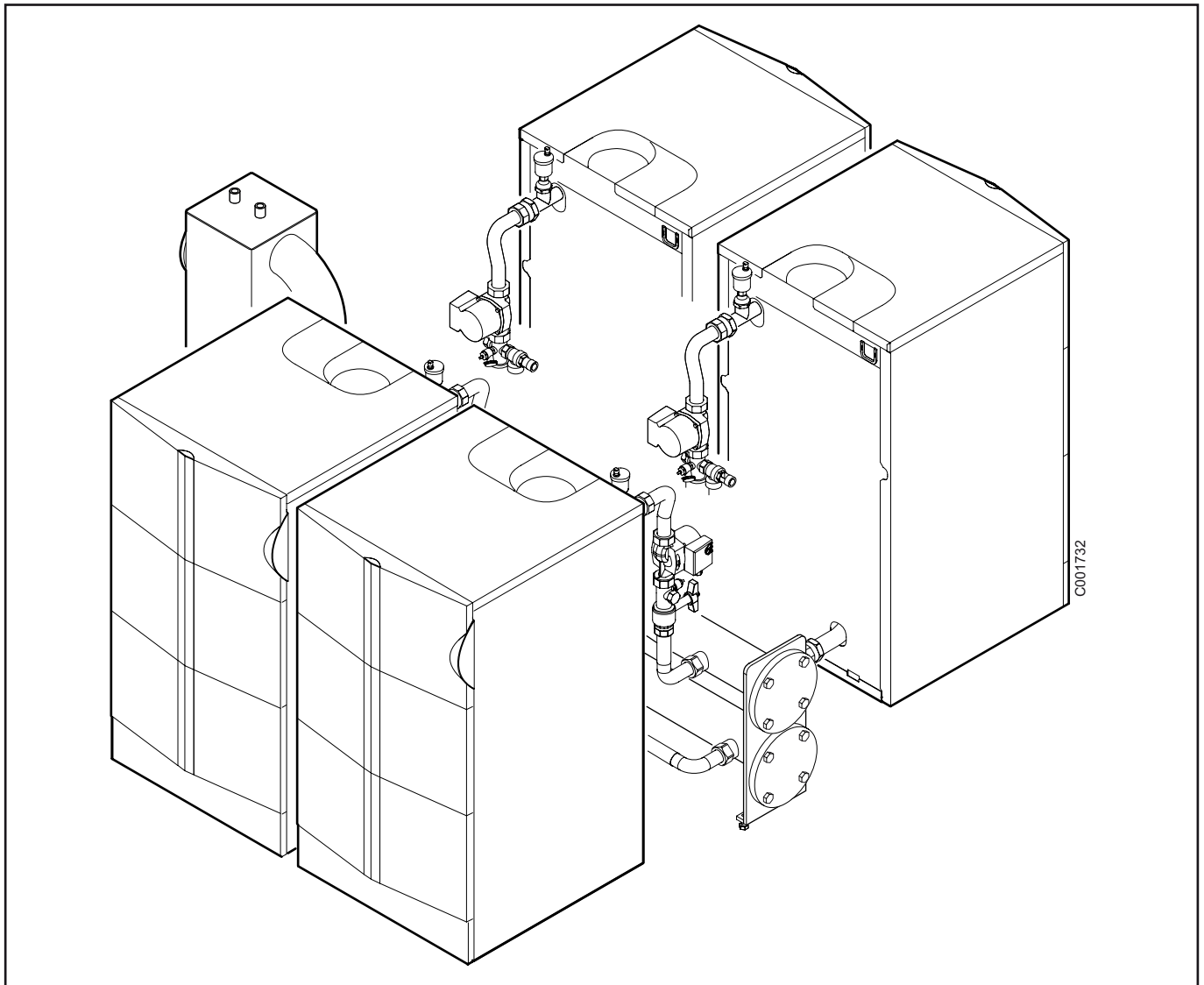

5 Composants

5 Components

5 Komponenten

5 Componenten

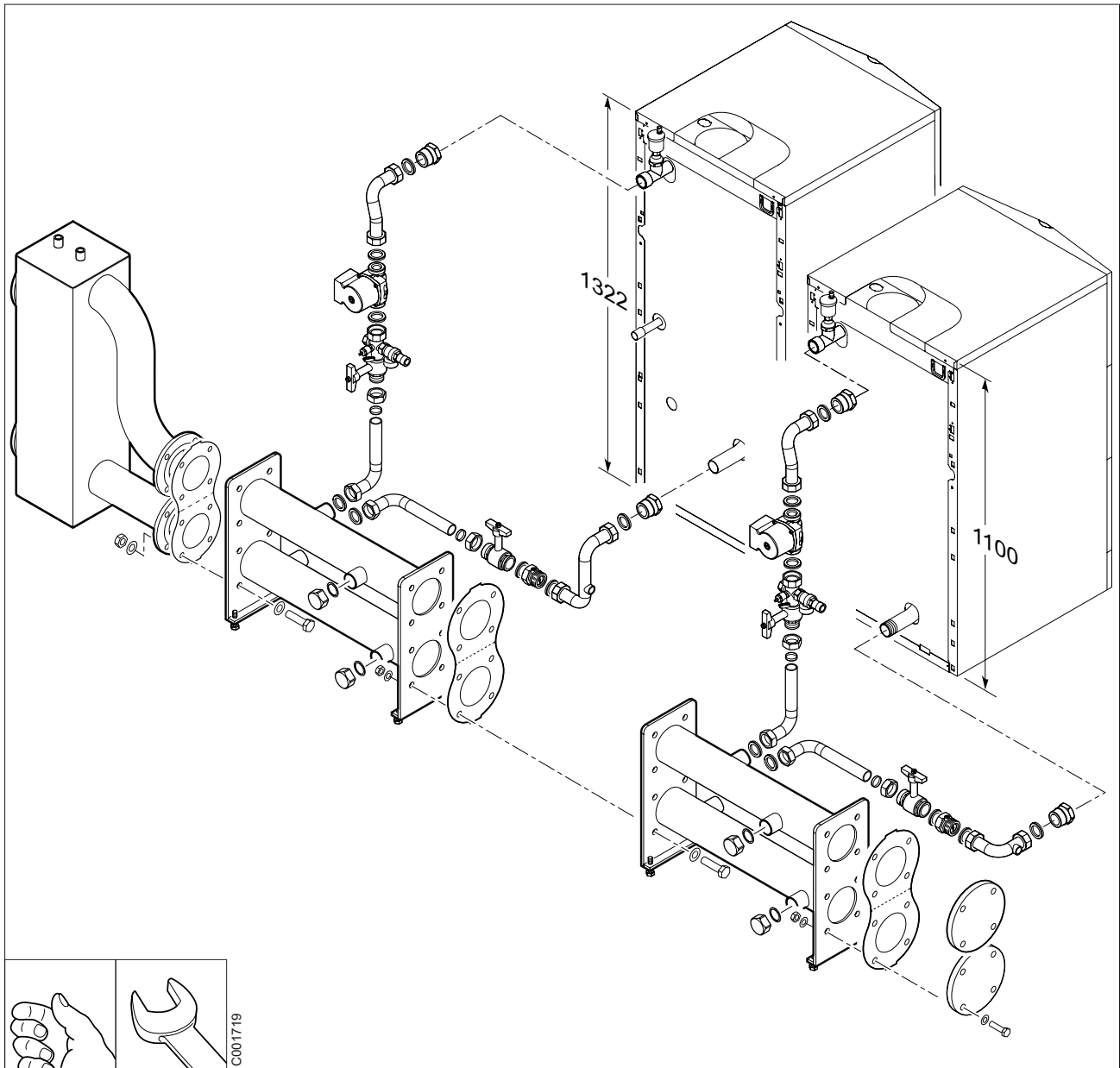

6 Assemblage

6 Montage

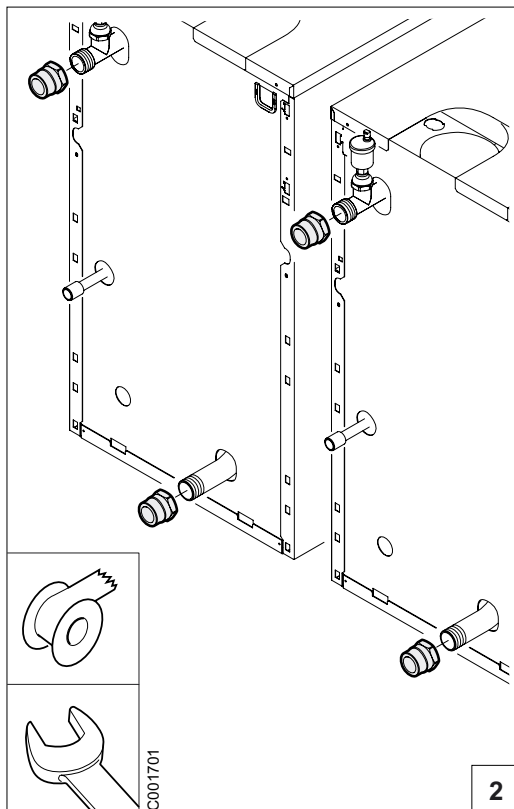
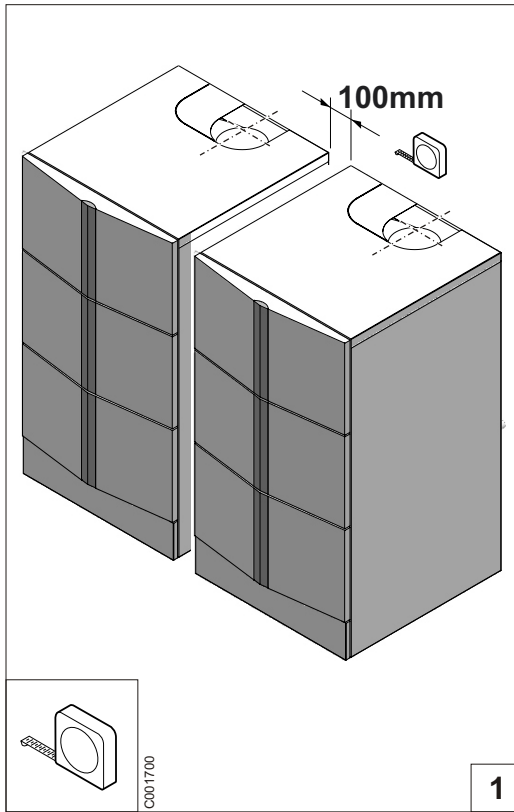

6 Assembly

6 Assemblage

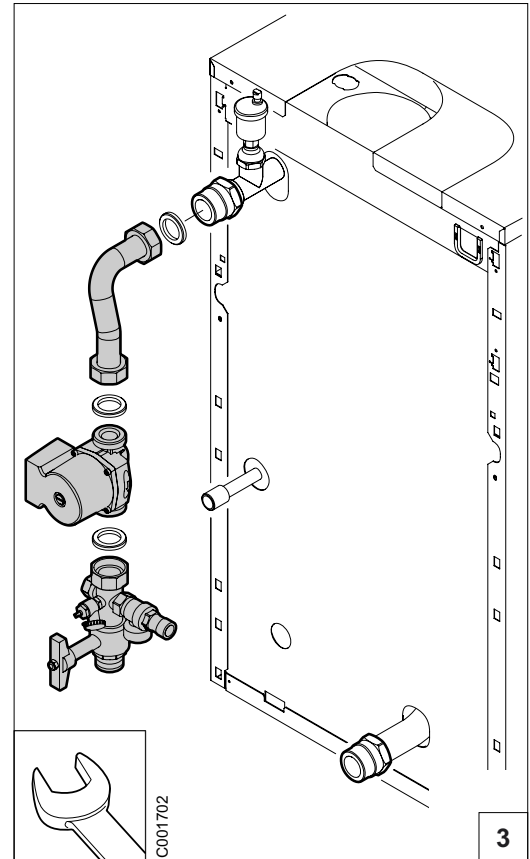

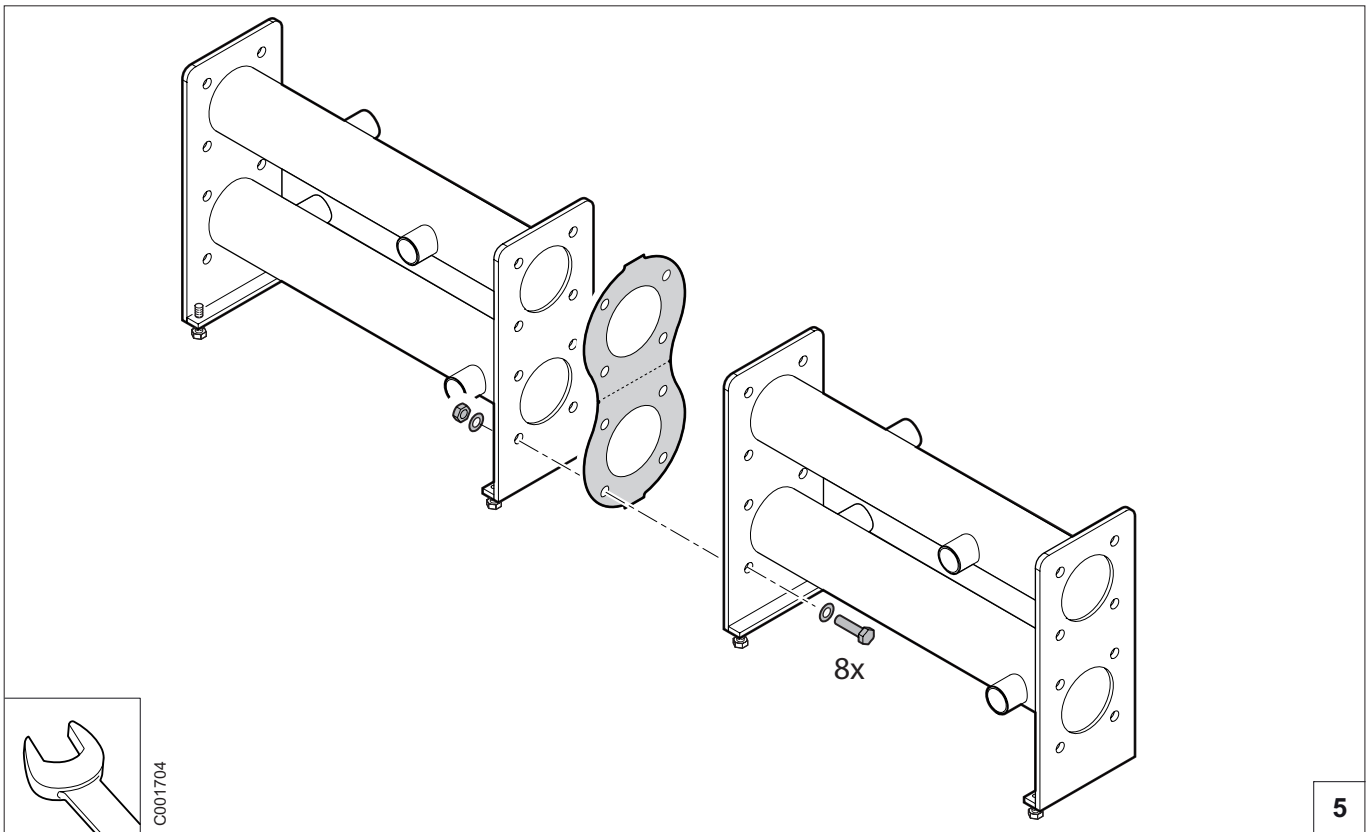
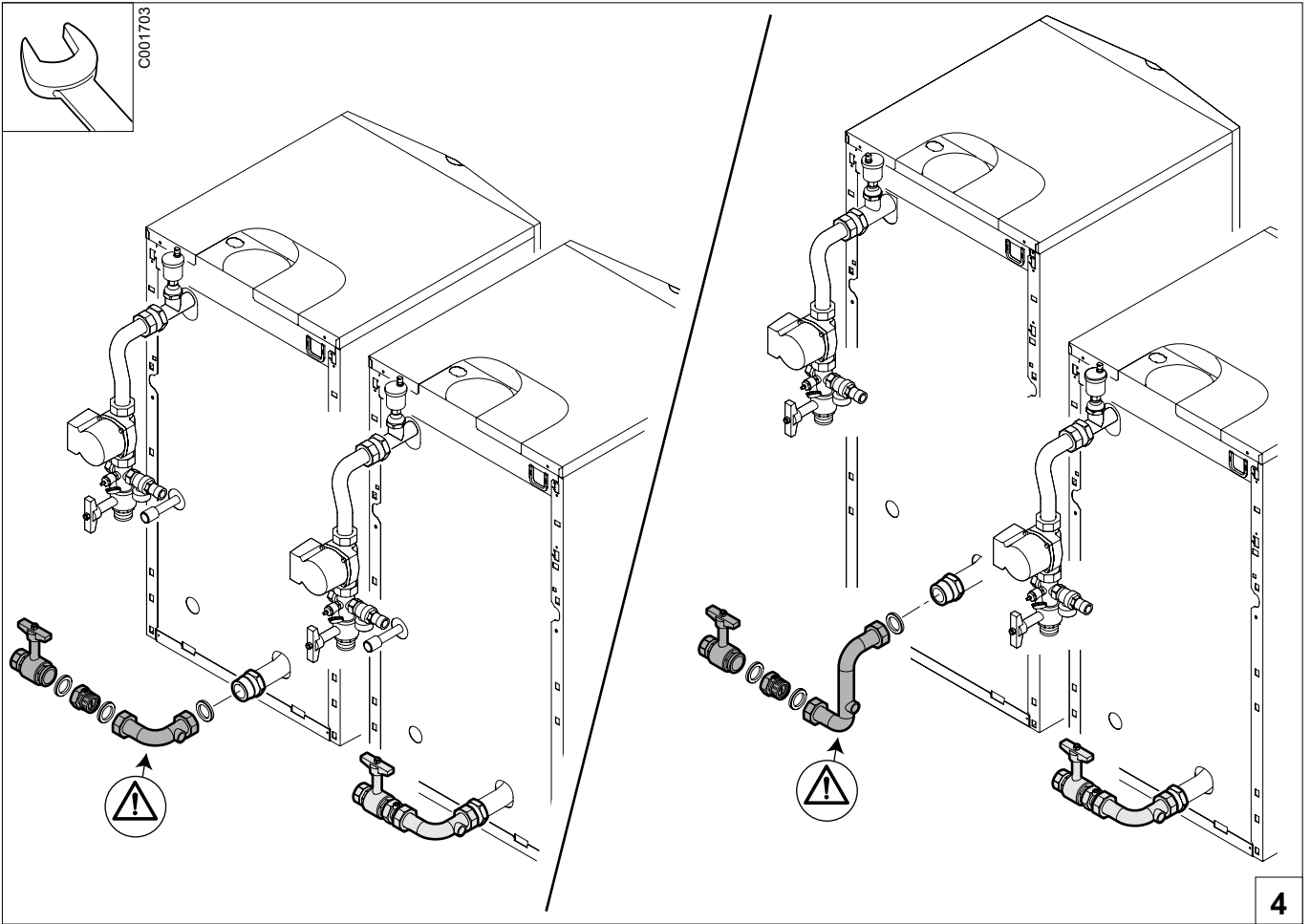

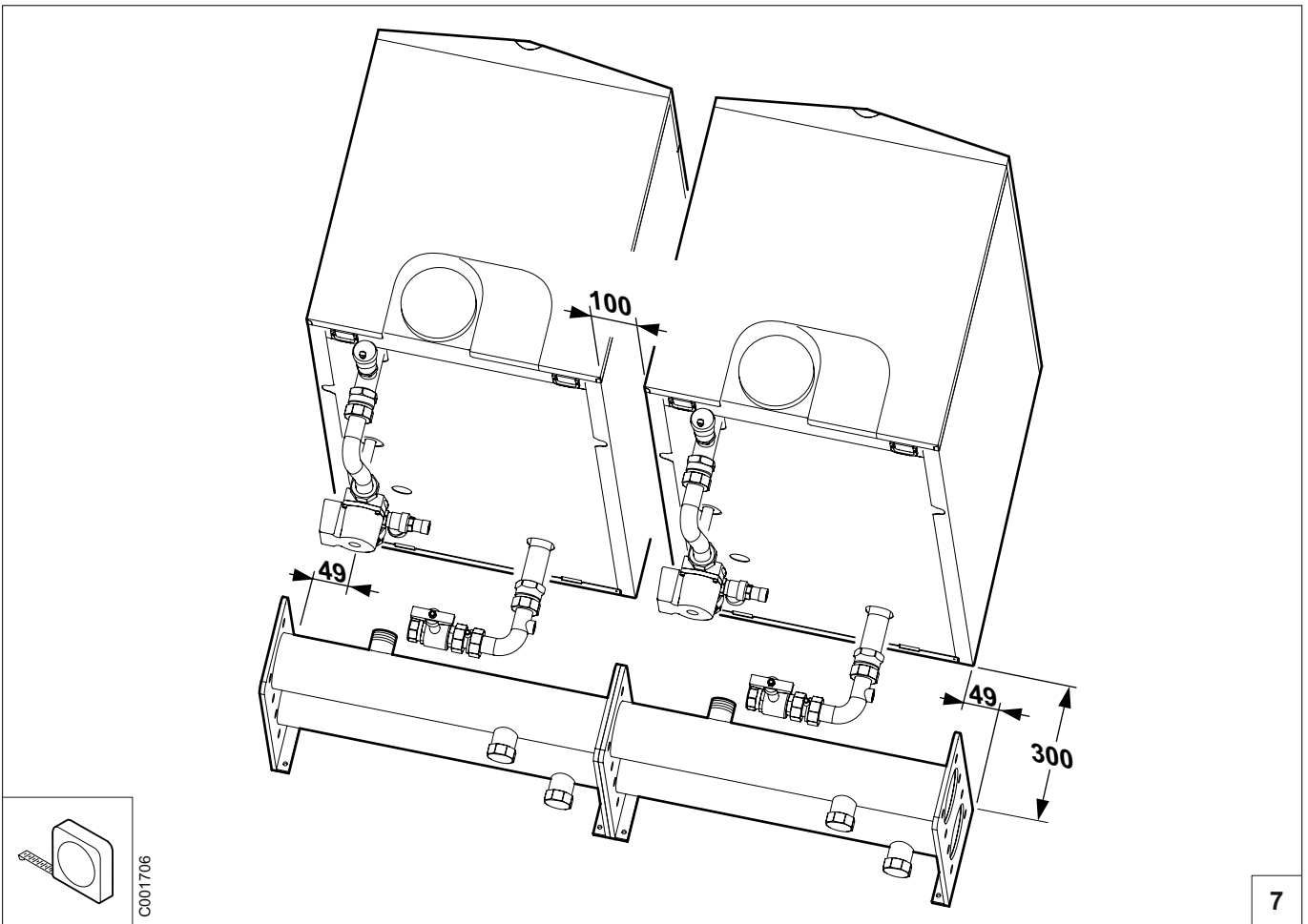
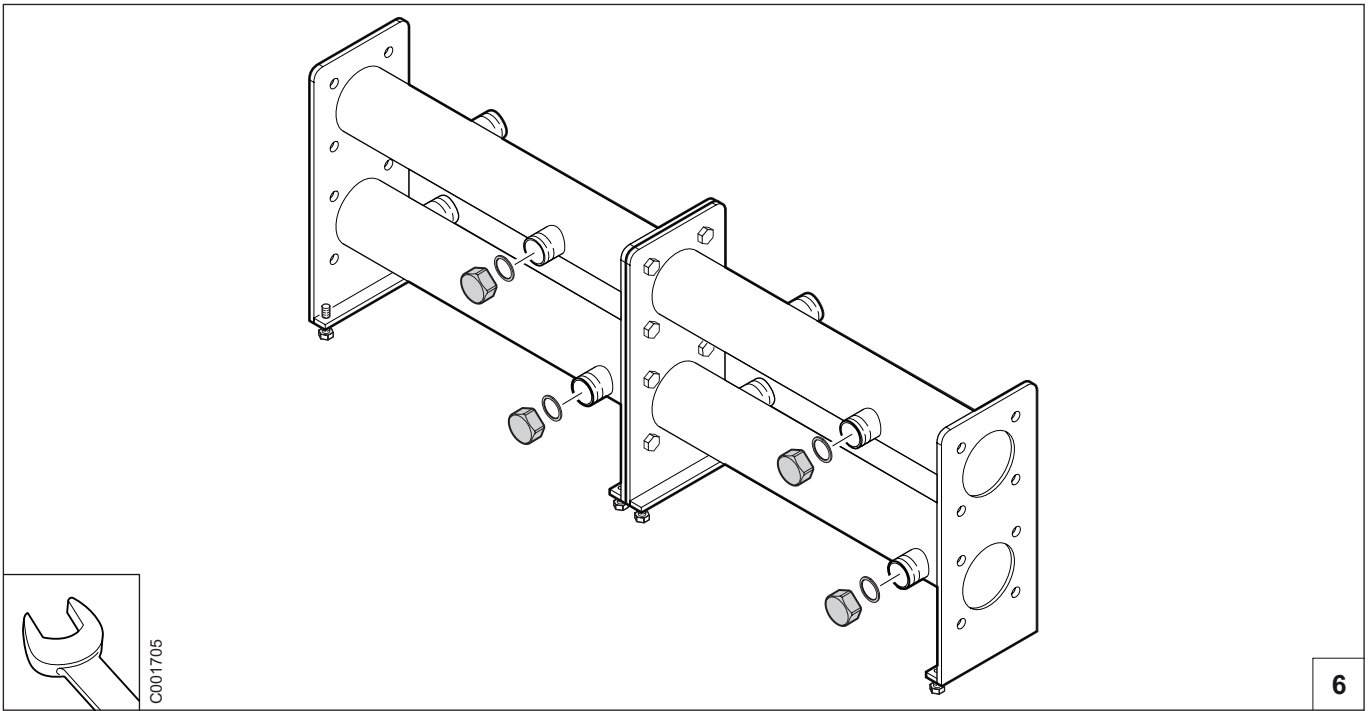

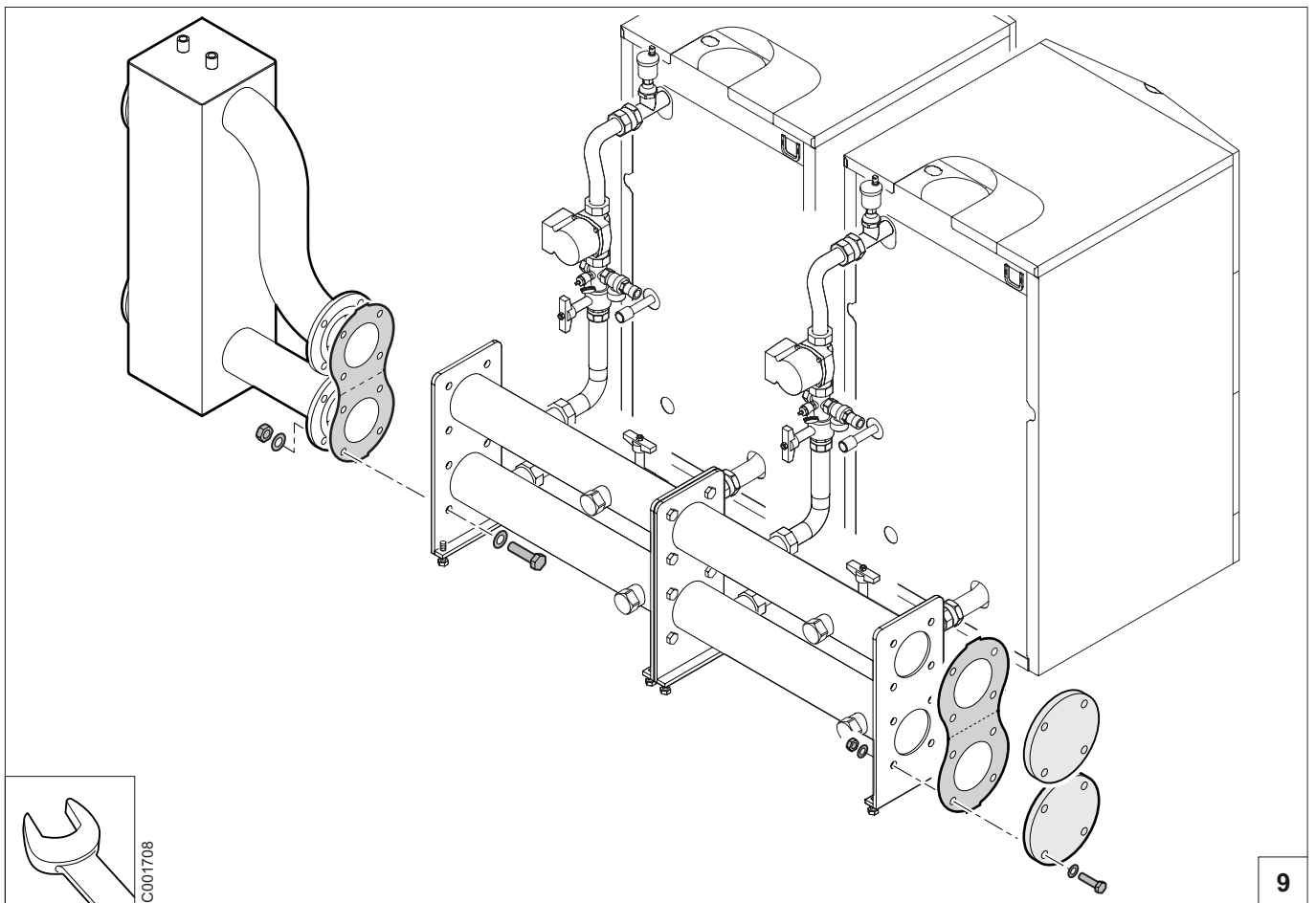
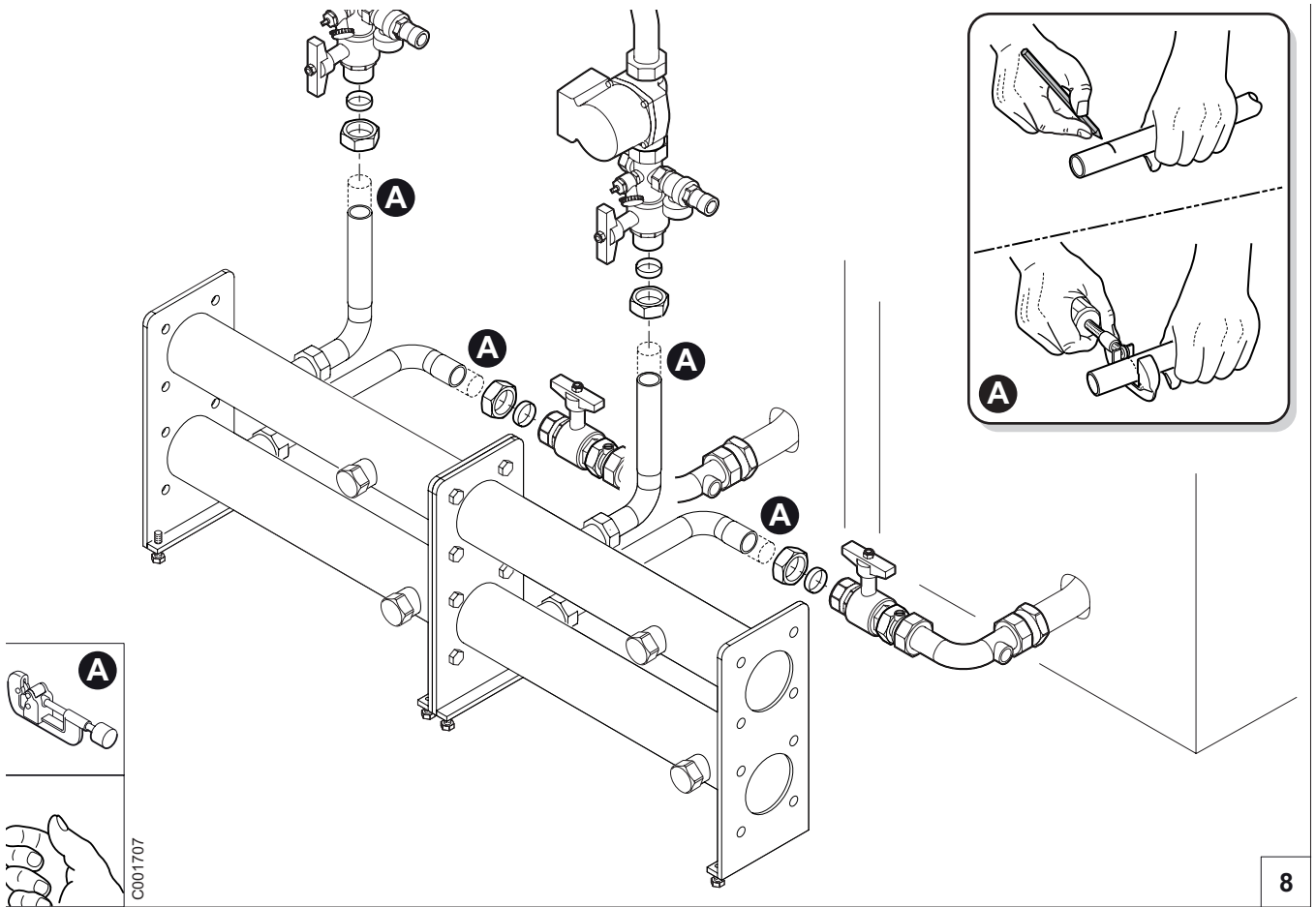

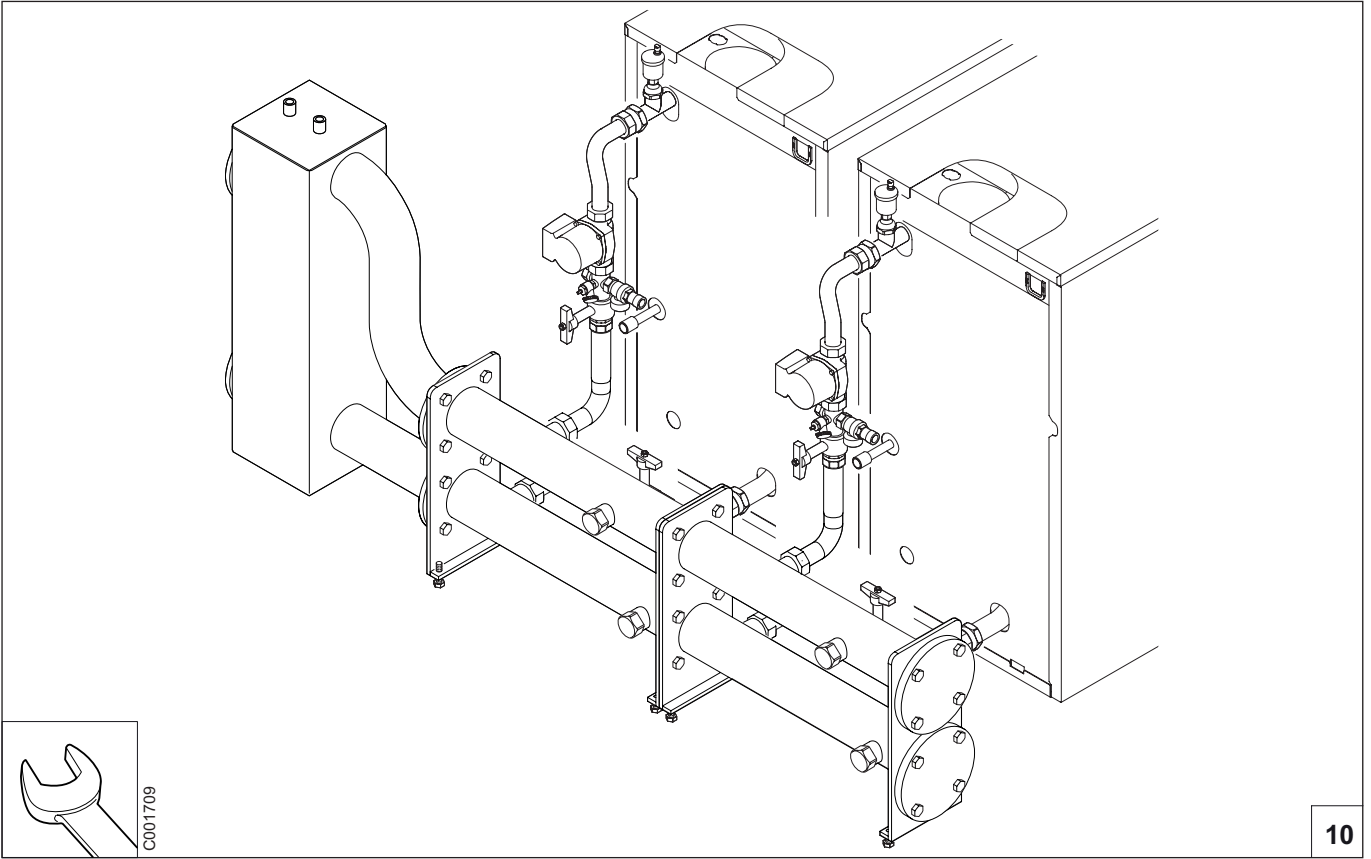

7 Montage des options

7 Montage der Zubehöre

7.1 Brides à souder

7.1 Schweißflansche

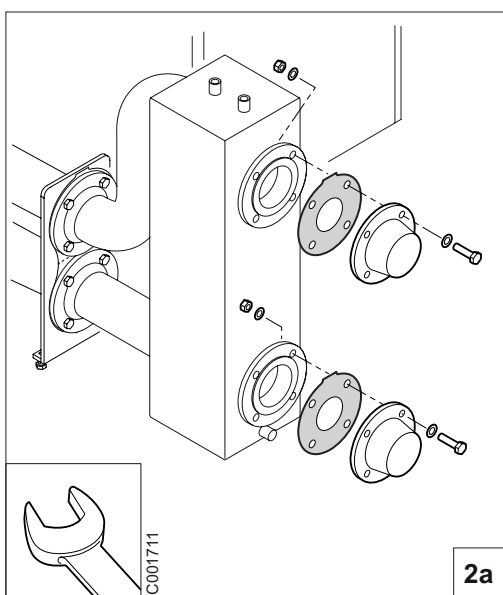
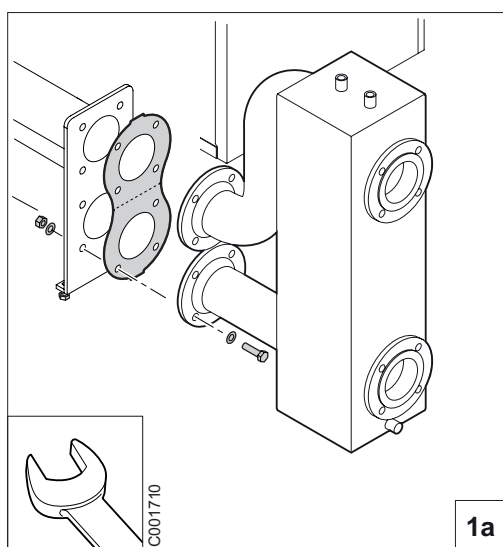

7 Installing options

7 Montage van de opties

7.1 Connecting flanges

7.1 Lasflenzen

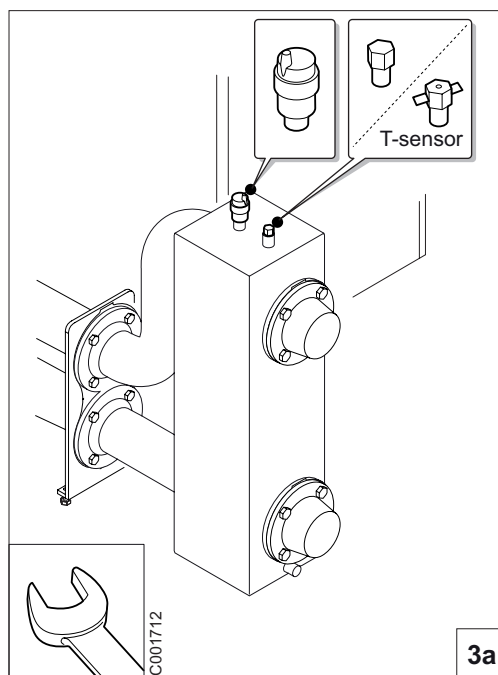

7.2 Coude 90°

7.2 Bogen 90°

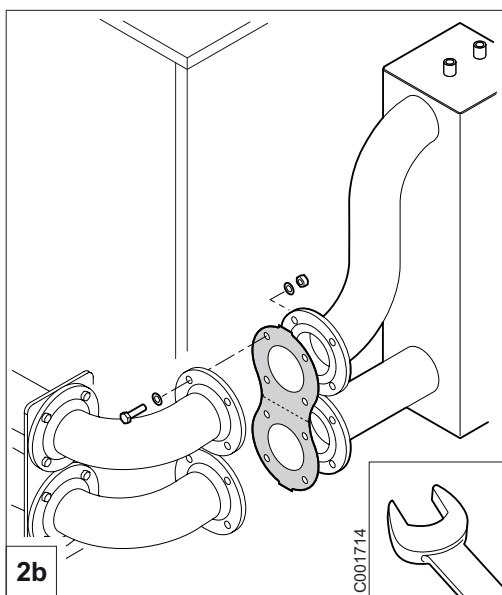
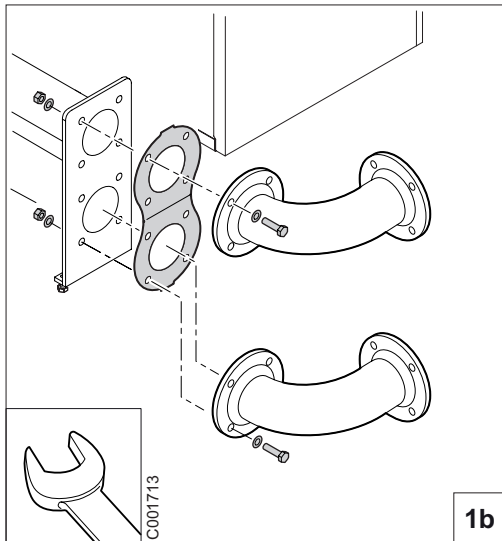

7.2 Elbow 90°

7.2 Bochtstuk 90°

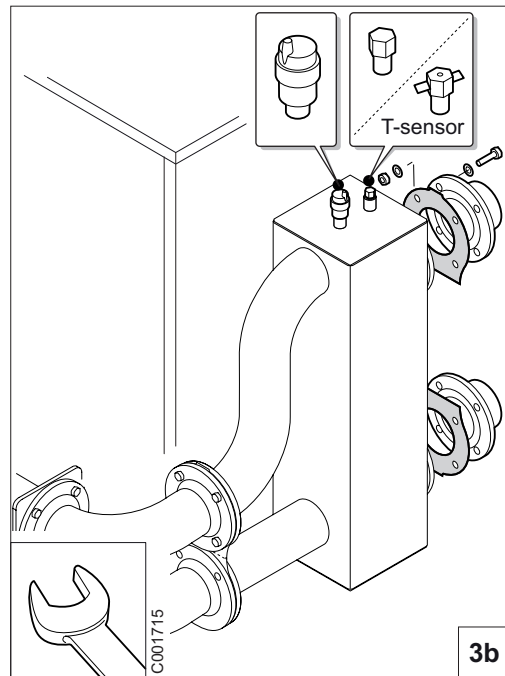

7.3 Isolation de la bouteille de découplage

7.3 Isolierung des thermohydraulischen Verteilers

7.3 Low-loss header insulation

7.3 Isolatie van de thermohydraulische verdeler

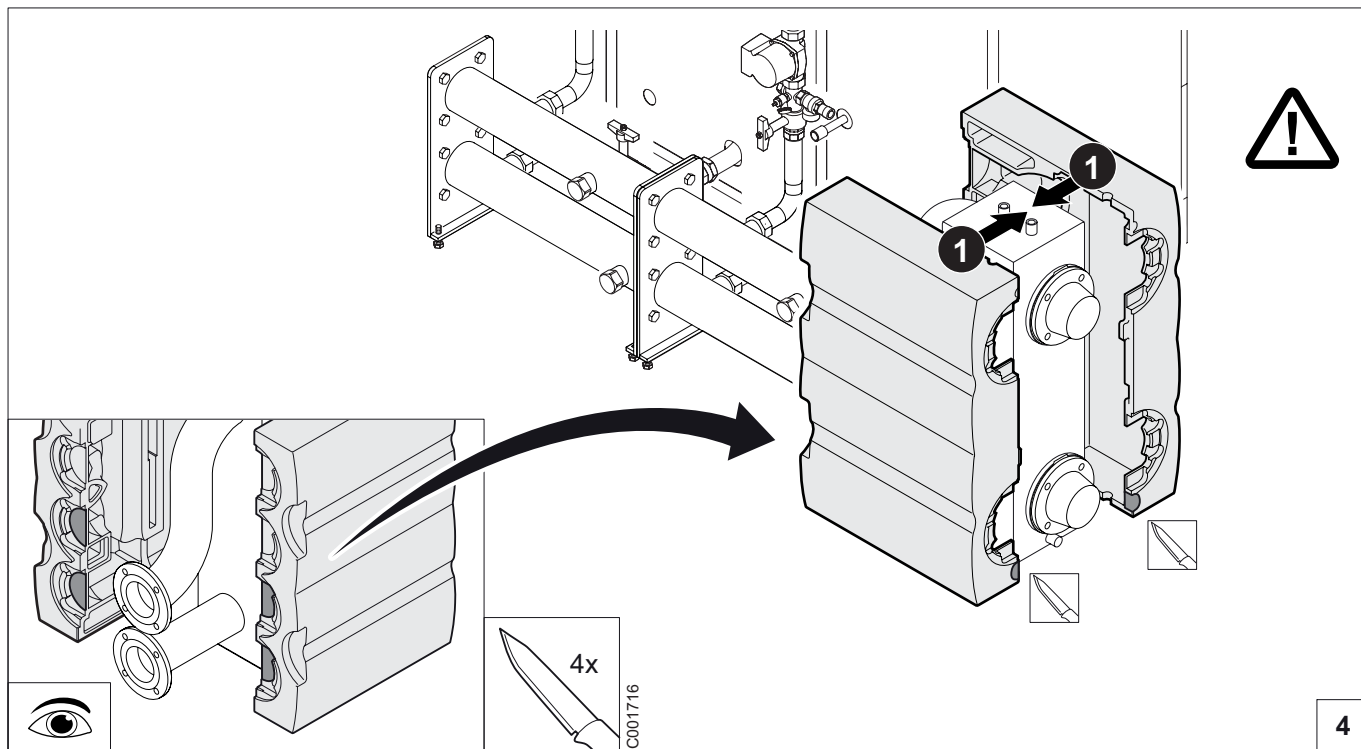

FR

DE

EN

NL

IT

ES

PL

RU

Cascade 35-115 kW



Istruzioni di montaggio
Instrucciones de montaje
Instrukcja montażu
Инструкция по монтажу

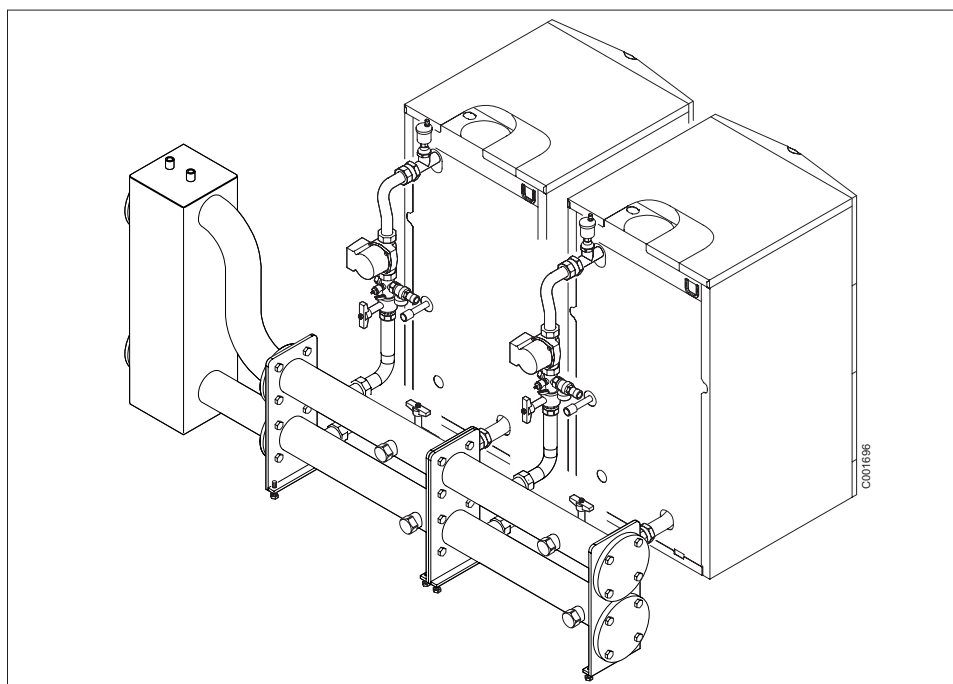

1 Utensili e materiali necessari

1 Herramientas y materiales necesarios

1 Wymagane narzędzia

1 Необходимые инструменты

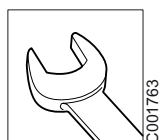

13 - 19 - 24 - 46 - 48 - 50 - 52 - 55

2 Raccomandazioni

2 Recomendaciones

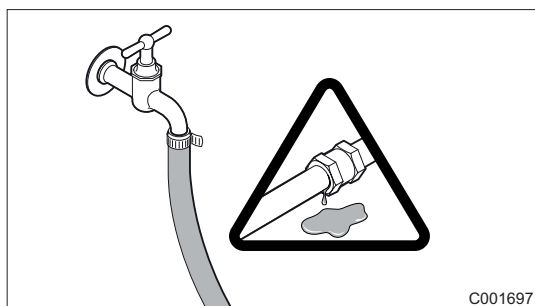
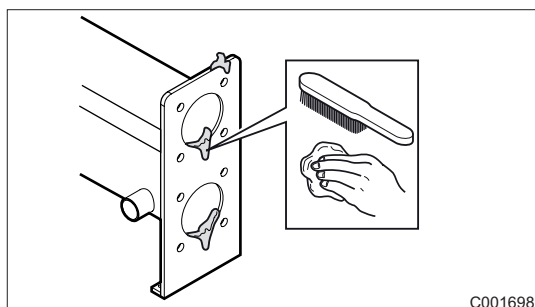
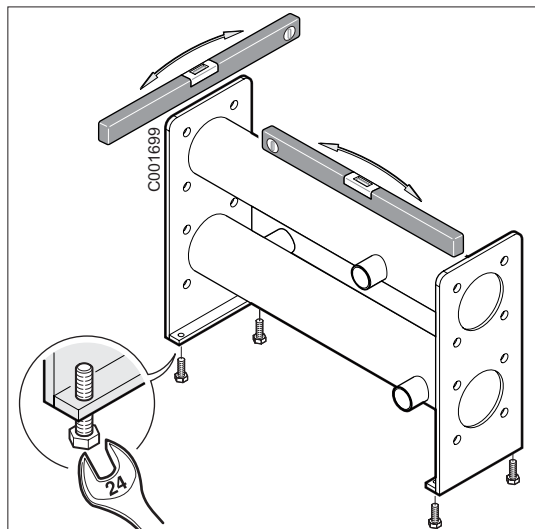

2 Zalecenia

2 Рекомендации

i Per il montaggio dei vari componenti, utilizzare materiali di tenuta approvati.

i **Prova idraulica:**
Dopo il montaggio delle caldaie e del sistema a cascata, è necessario effettuare una prova idraulica.

- ▶ Tappare i collegamenti di mandata e di ritorno.
La pressione di prova ad acqua fredda deve essere di 1.3 x la pressione di esercizio.

i Usar materiales de estanqueidad aprobados para montar los distintos componentes.

i **Prueba hidráulica:**
Después de montar las calderas y el sistema en cascada, es necesario hacer una prueba hidráulica.

- ▶ Taponar las conexiones de salida y retorno.
La presión de prueba al agua fría debe ser de 1.3 x la presión de servicio.

i Zaślepić połączenia zasilania i powrotu.

i **Próba ciśnieniowa:**
Po montażu kotła i systemu kaskadowego należy przeprowadzić próbę szczelności układu hydraulicznego.

- ▶ Zaślepić połączenia zasilania i powrotu.
Ciśnienie wody zimnej musi odpowiadać wartości 1.3 x ciśnienie robocze.

i Для монтажа различных компонентов использовать подходящие материалы для герметичности.

i **Гидравлическое испытание :**
После монтажа котлов и каскадной системы необходимо выполнить гидравлическое испытание.

- ▶ Заглушить присоединения подающей и обратной линии.
Испытательное давление холодной водой должно быть 1.3 x рабочее давление.

3 Imballaggio

3 Zakres dostawy

3 Empaquetado

3 Упаковка

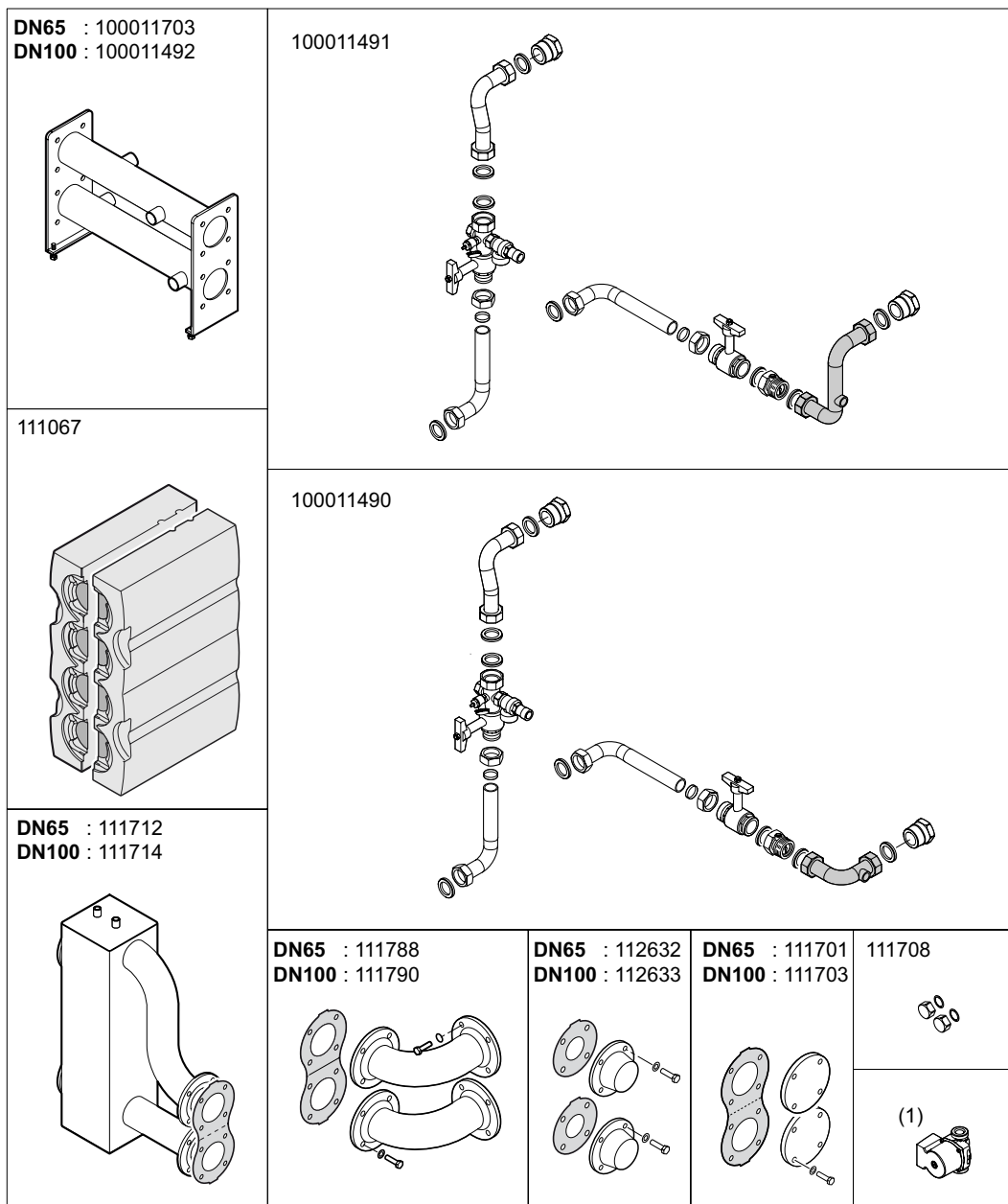

C001605

(1) Pompa da gestire in funzione della potenza della caldaia.

(1) Zamówić pompę w zależności od mocy kotła.

(1) Bomba regulada en función de la potencia de la caldera.

(1) Насос заказывается в зависимости от мощности котла.

4 Combinazioni possibili

4 Combinaciones posibles

4.1 LV

4 Dostępne wykonania

4 Возможные комбинации

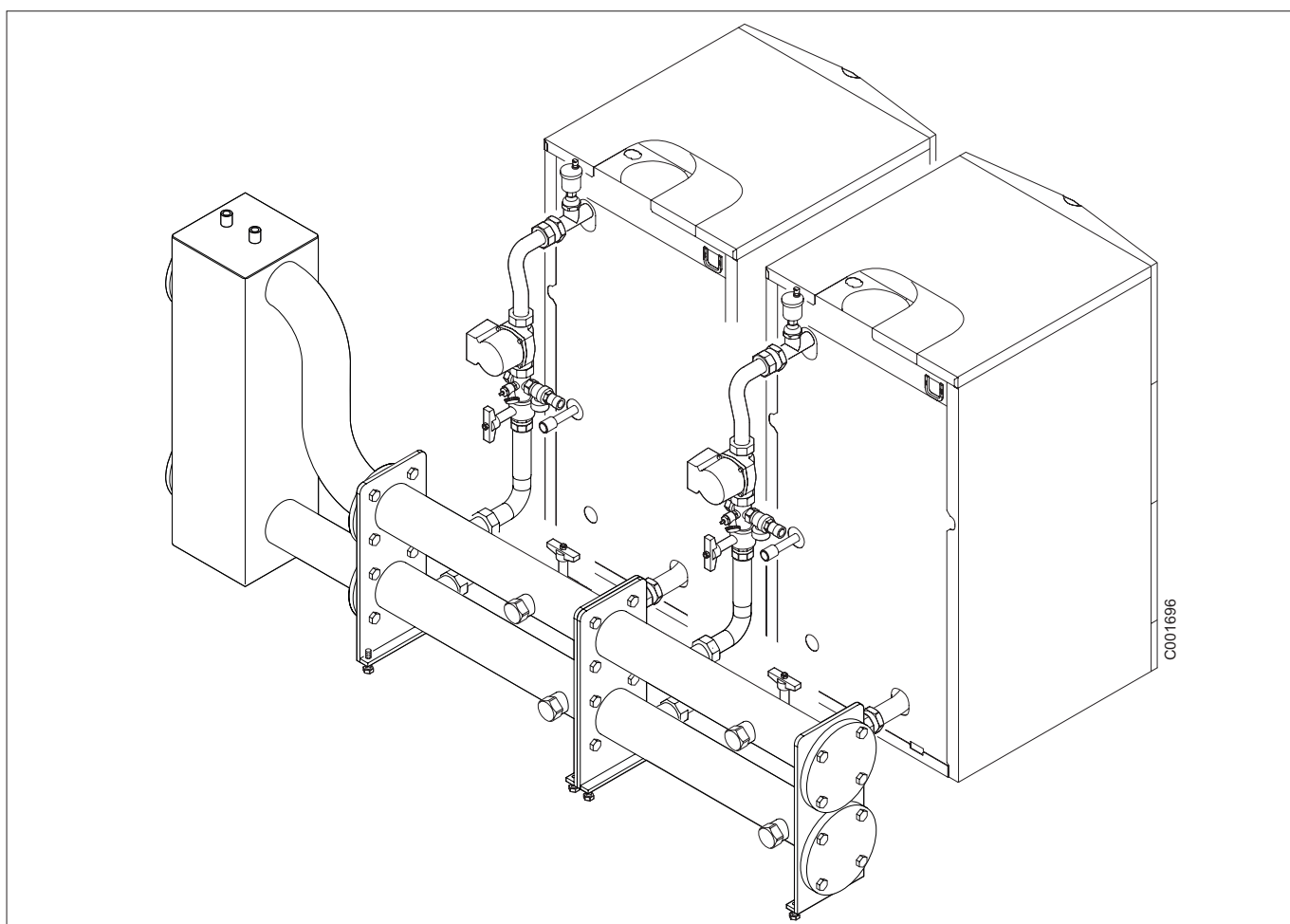

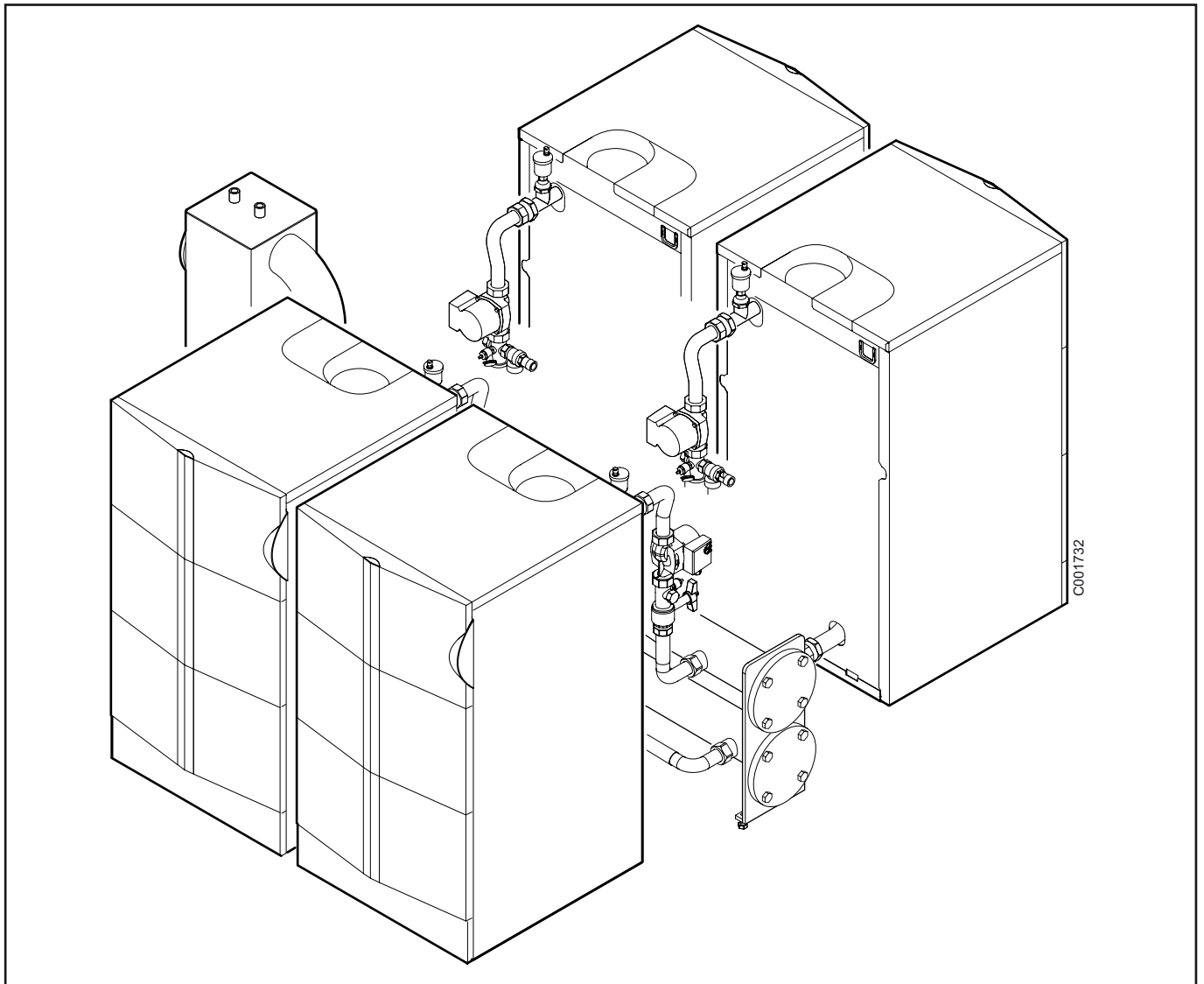

5 Componenti

5 Elementy

5 Componentes

5 Компоненты

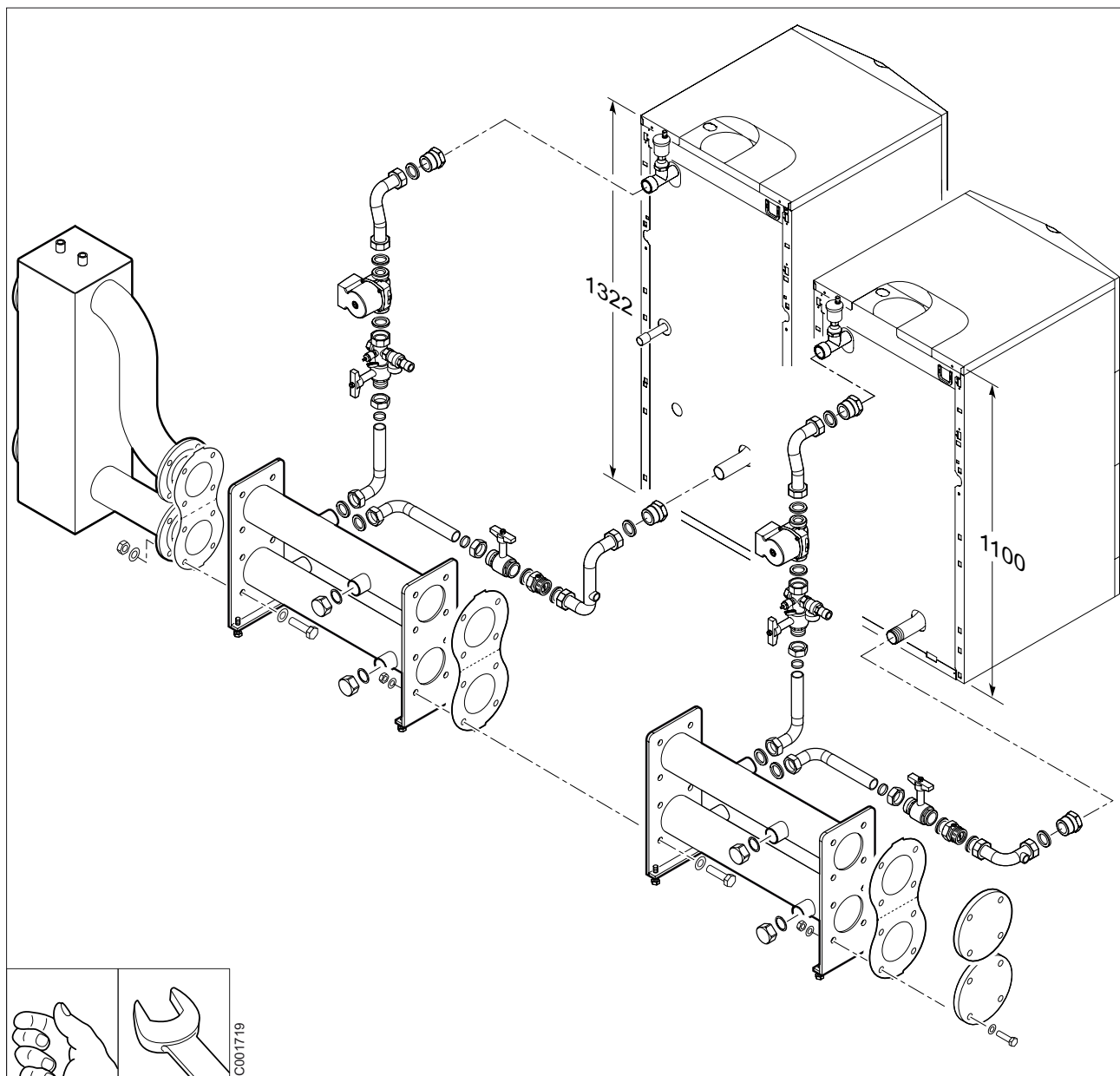

6 Montaggio

6 Ensamblaje

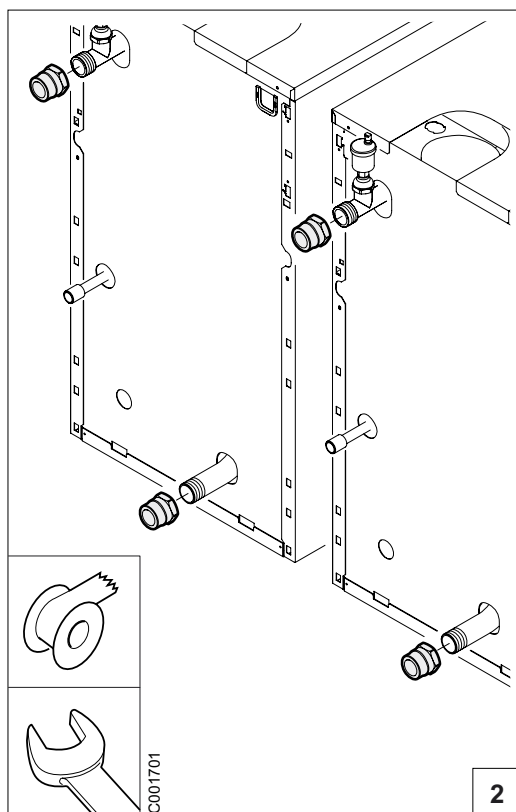
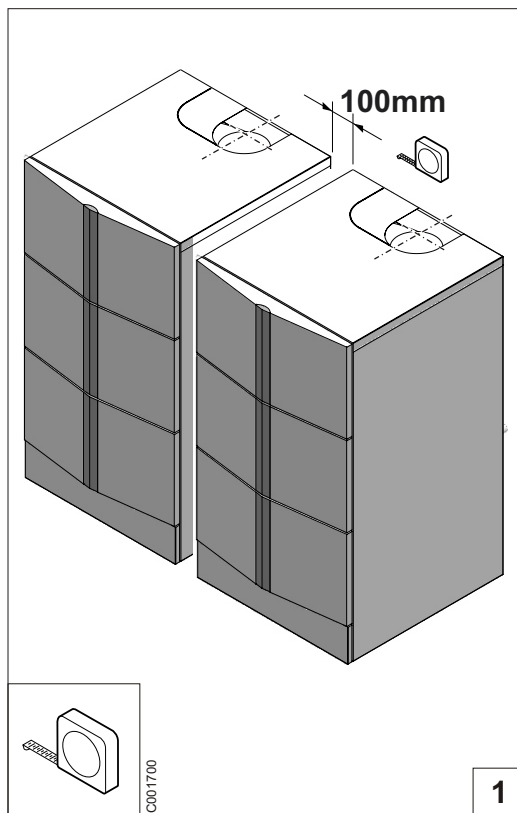

6 Montaż

6 Сборка

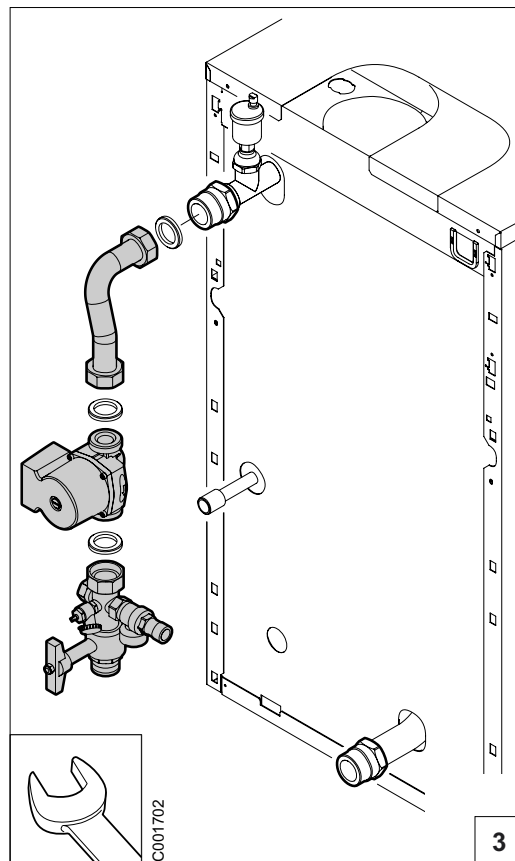

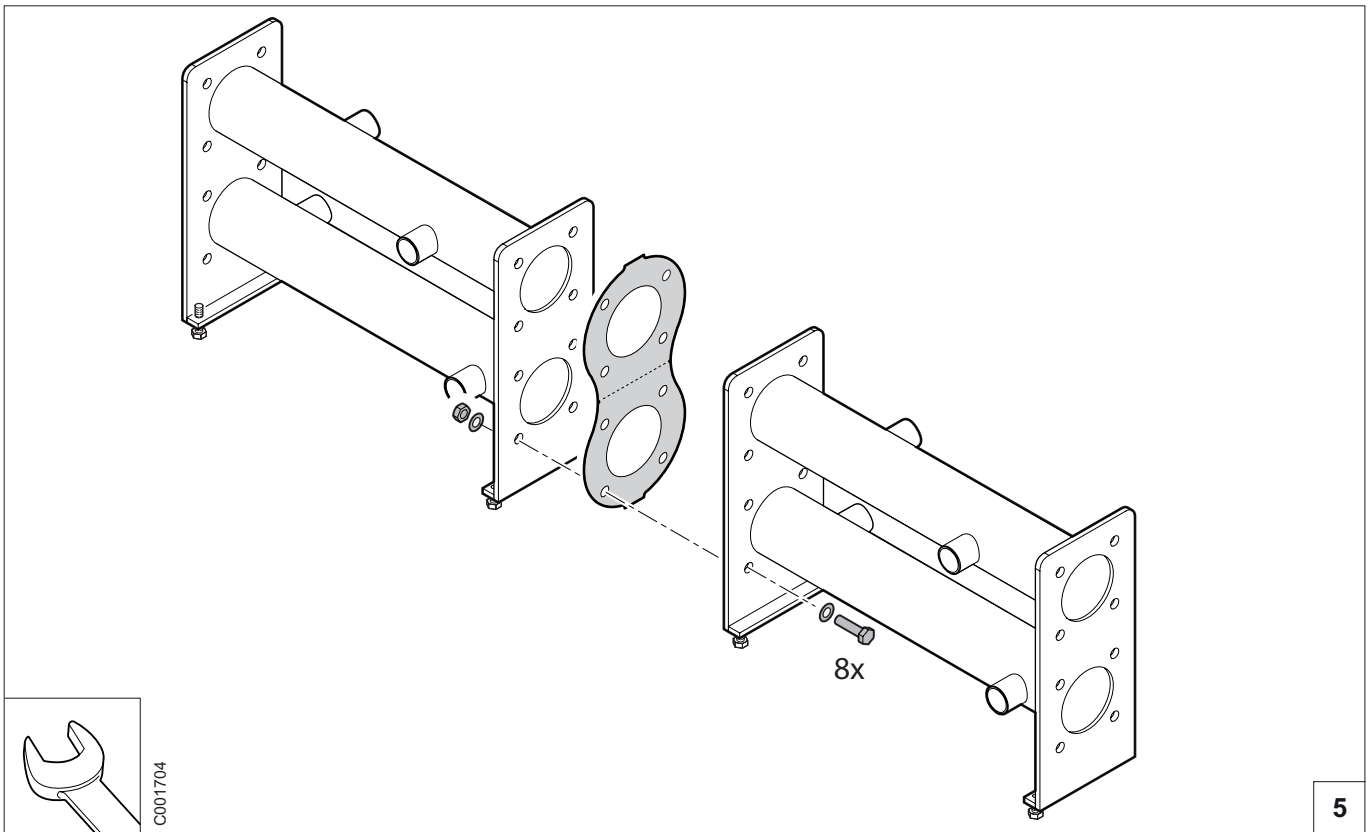
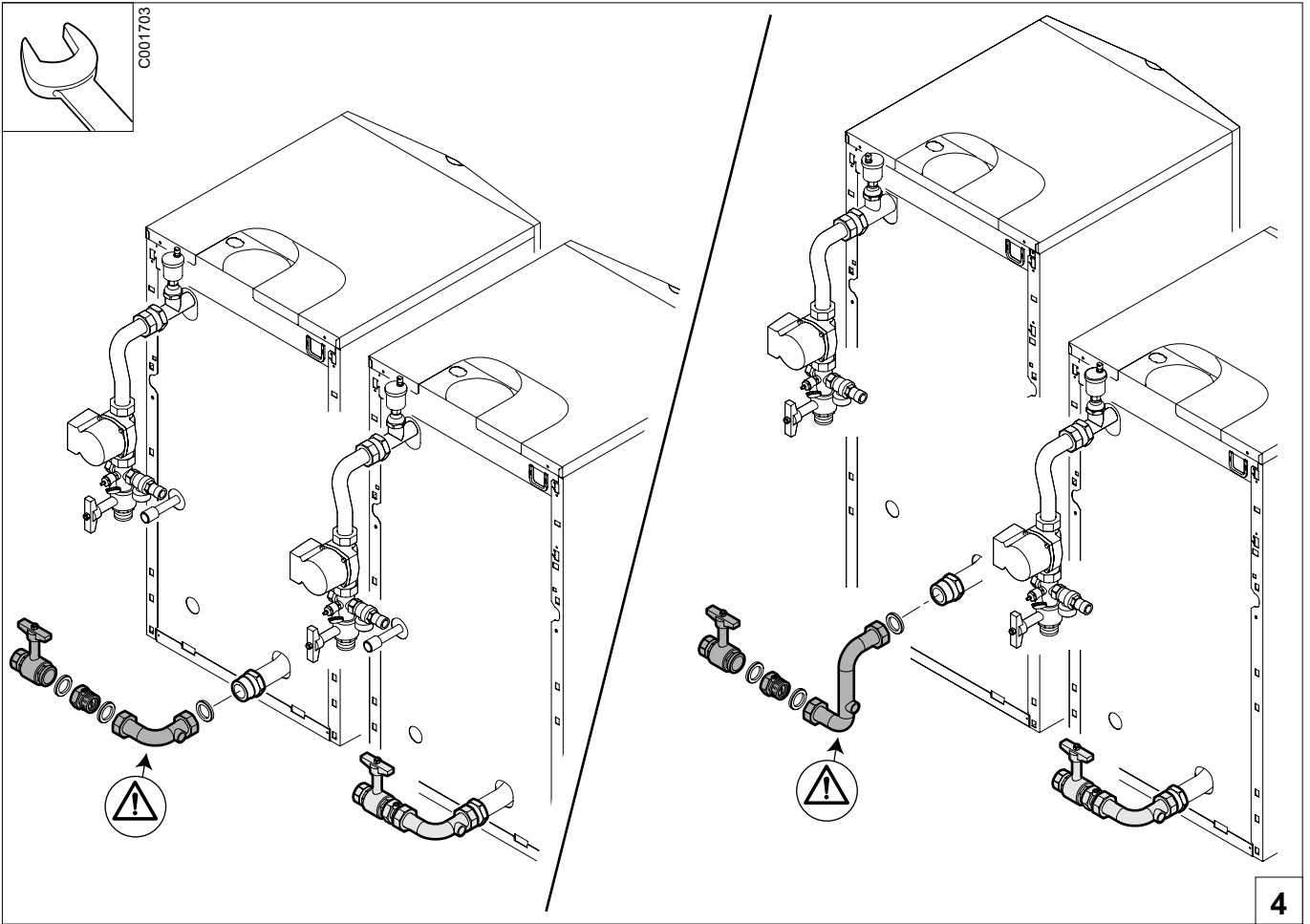

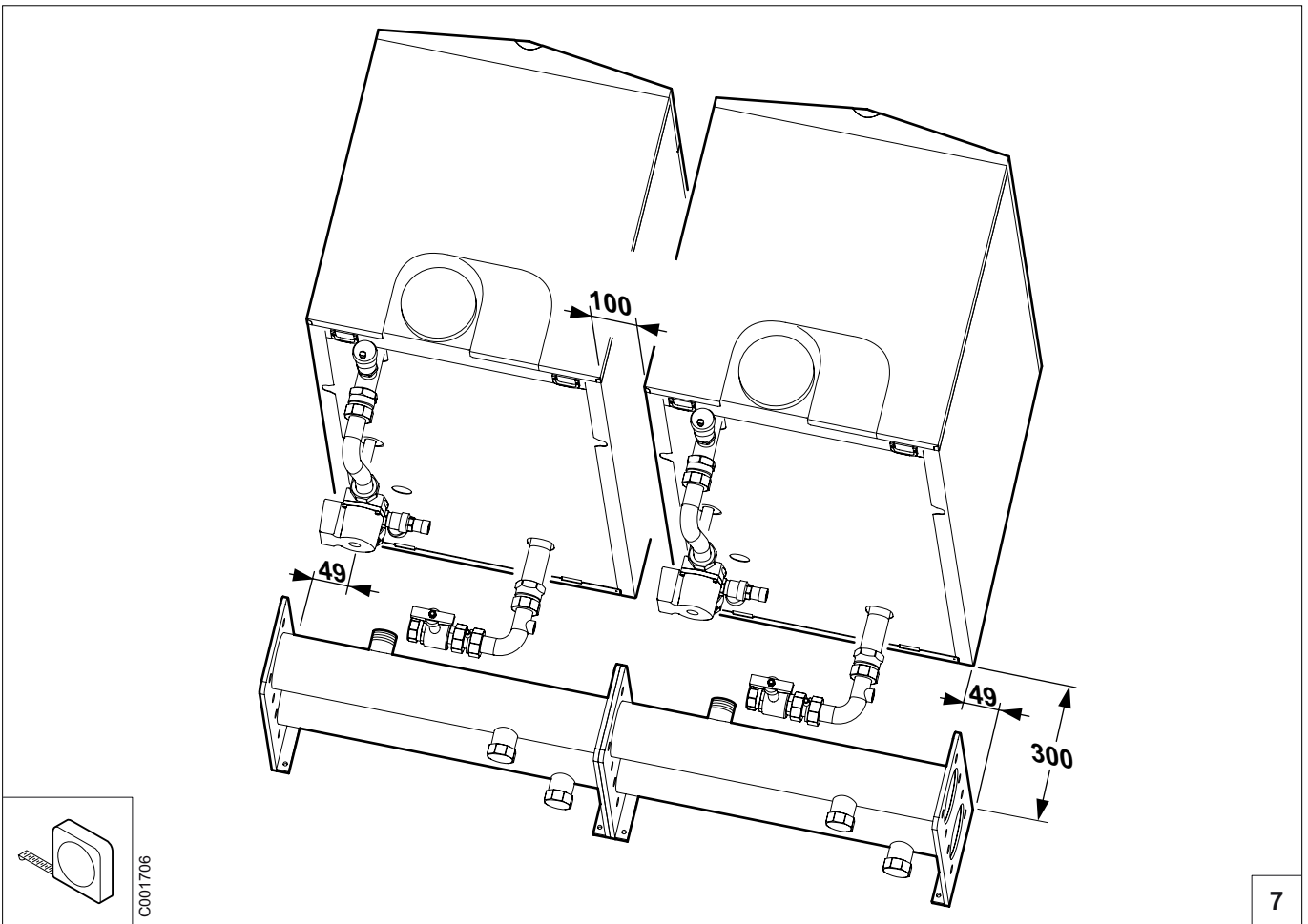
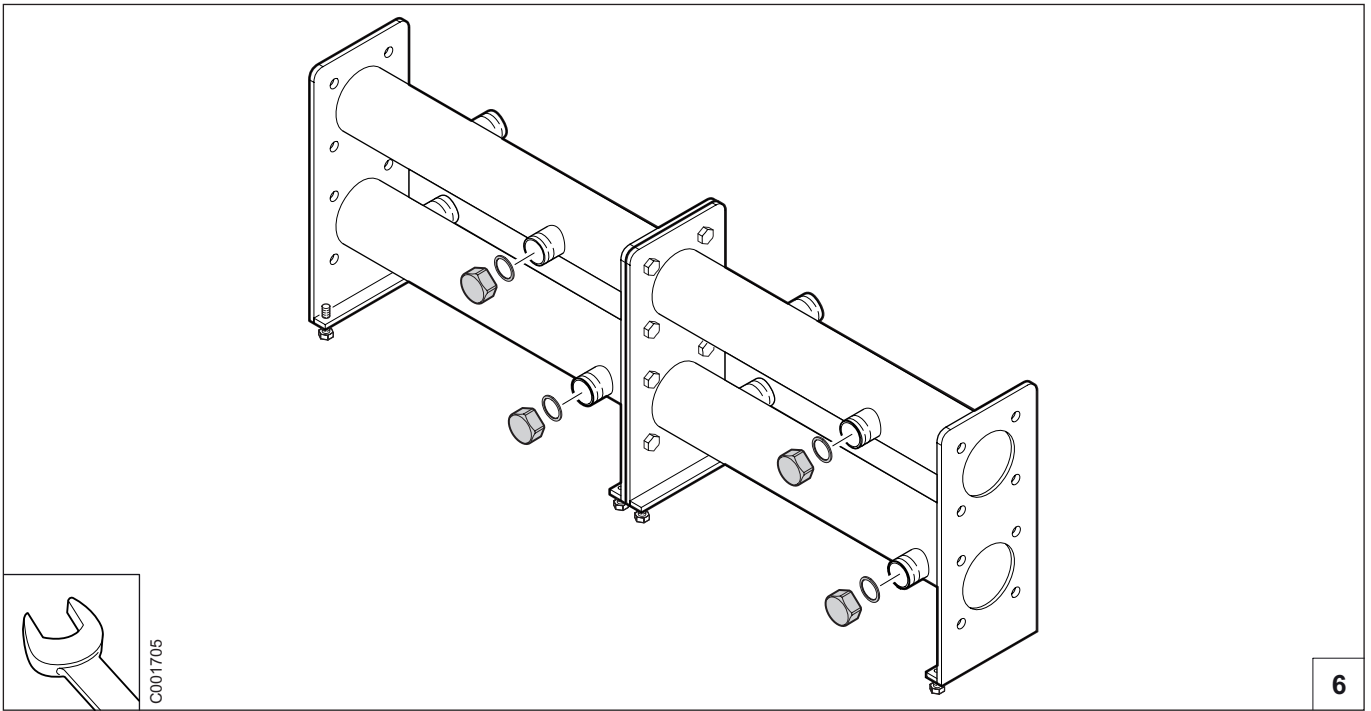

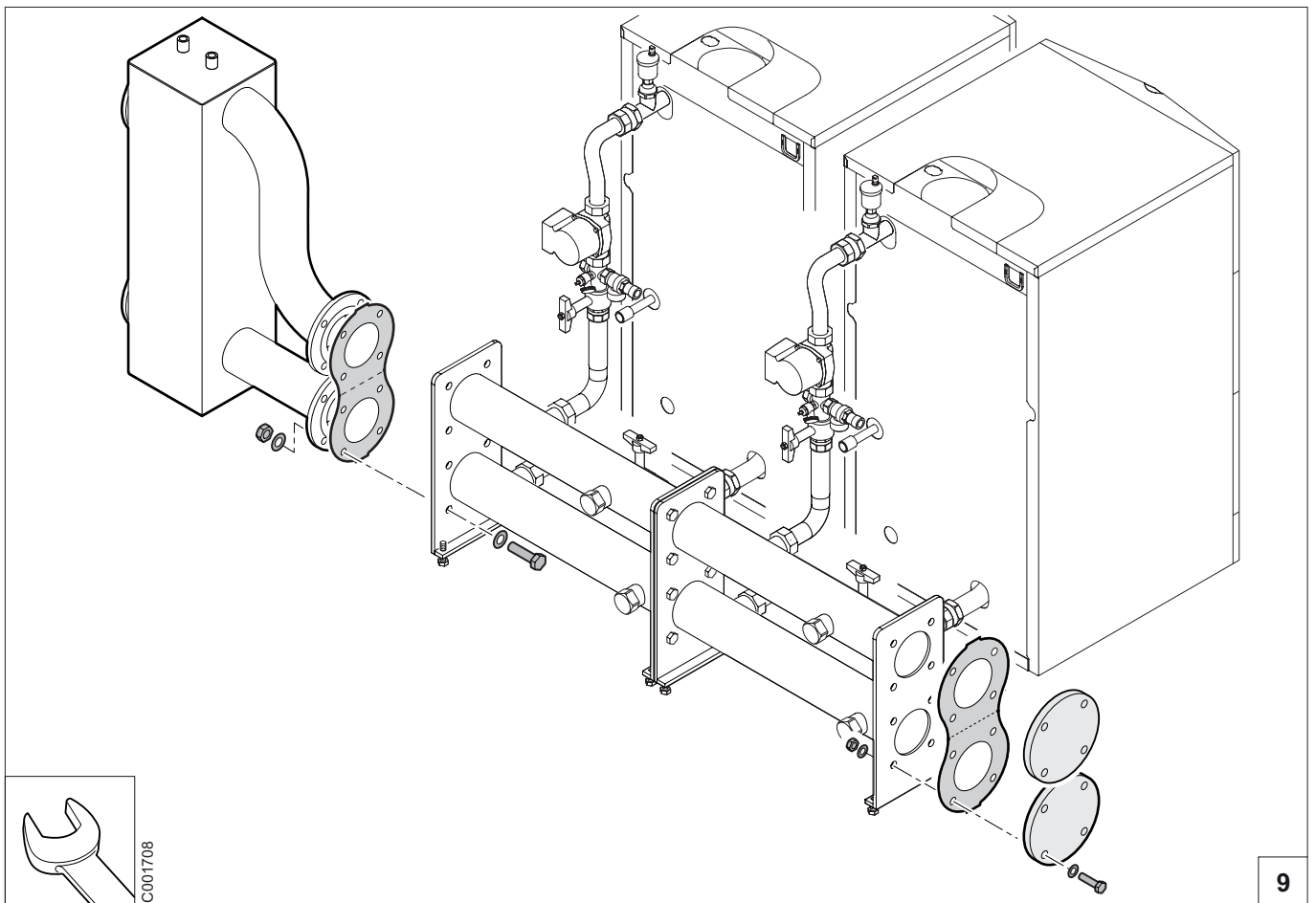
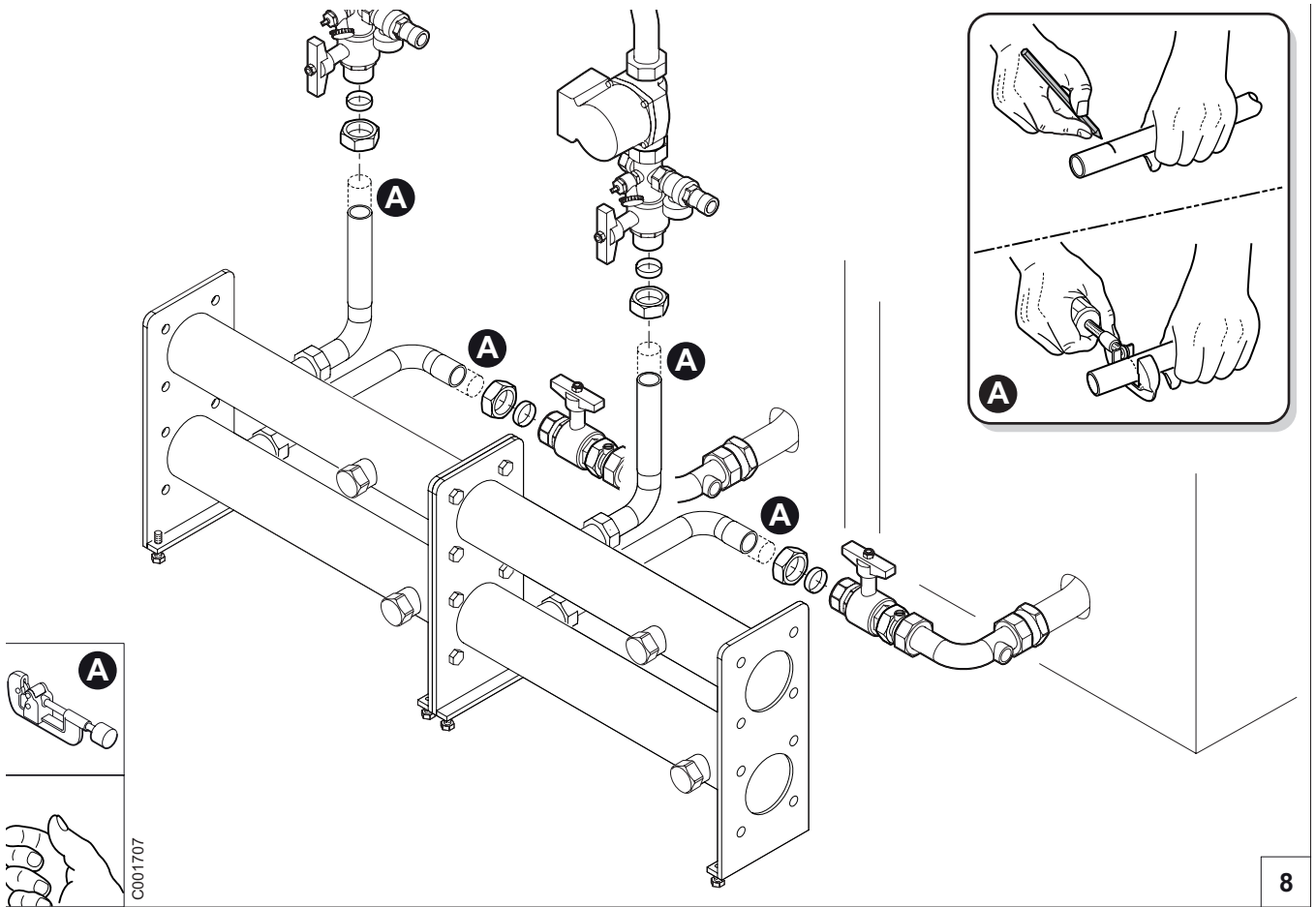

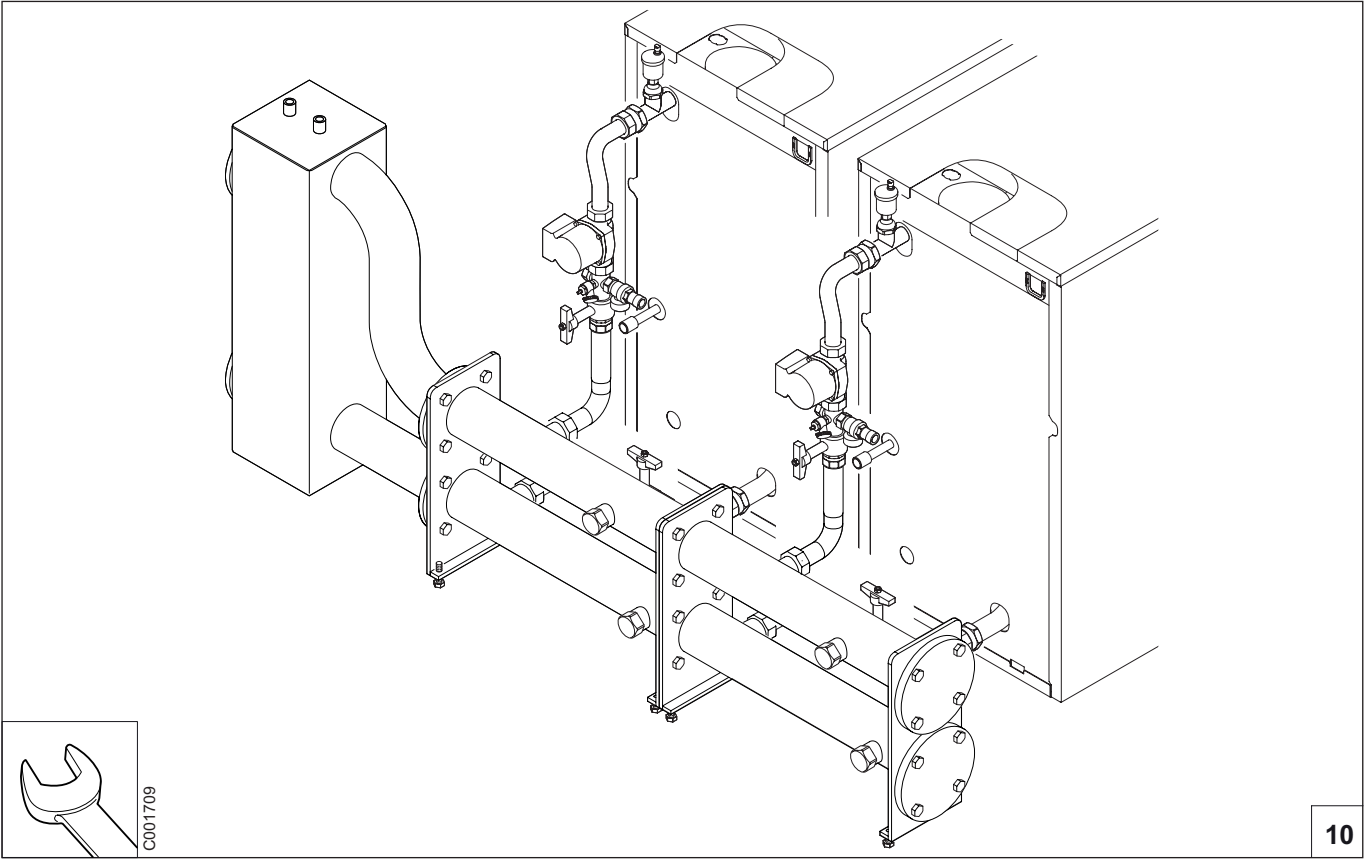

7 Montaggio delle opzioni

7 Montaje de las opciones

7.1 Flange da saldare

7.1 Bridas para soldar

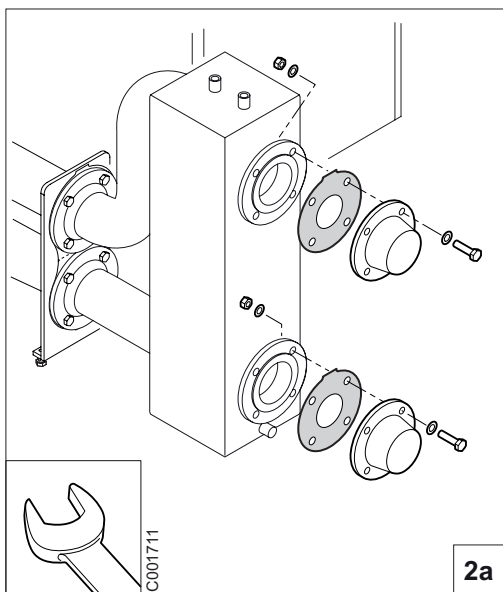
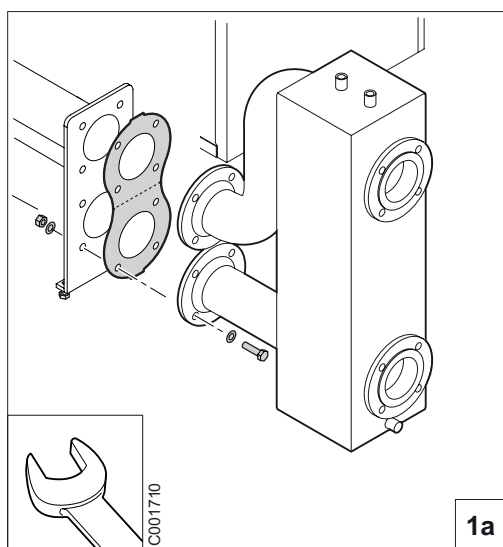

7 Montaż wyposażenia dodatkowego

7 Установка дополнительного оборудования

7.1 Flansa do przyspawania

7.1 Фланцы под сварку

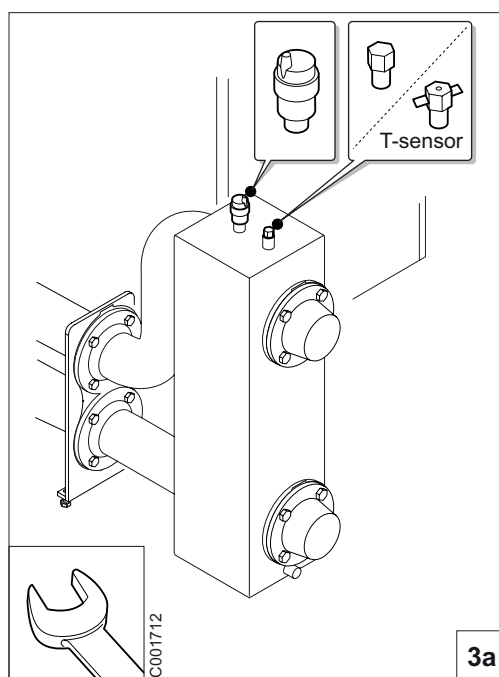

7.2 Curva 90°

7.2 Codo 90°

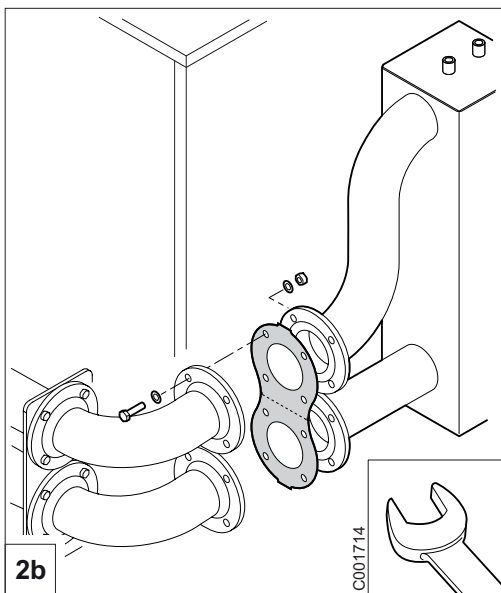
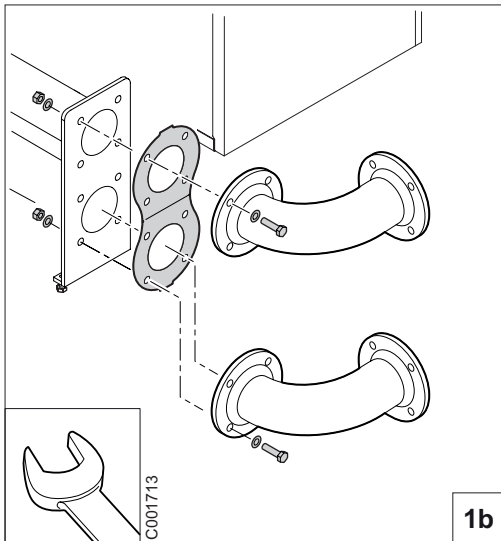

7.2 Kolano 90°

7.2 Колено 90°

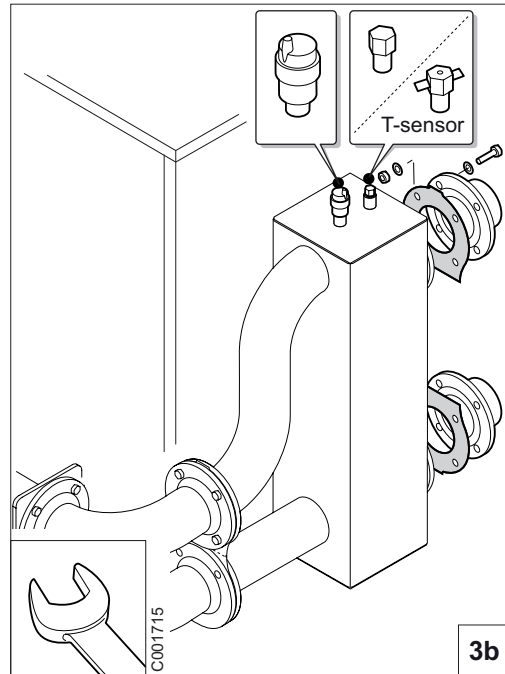

7.3 Isolamento del dispositivo di disaccoppiamento termoidraulico

7.3 Aislamiento de la botella de desacoplo

7.3 Izolacja sprzęgła hydraulicznego

7.3 Теплоизоляция гидравлического разделителя

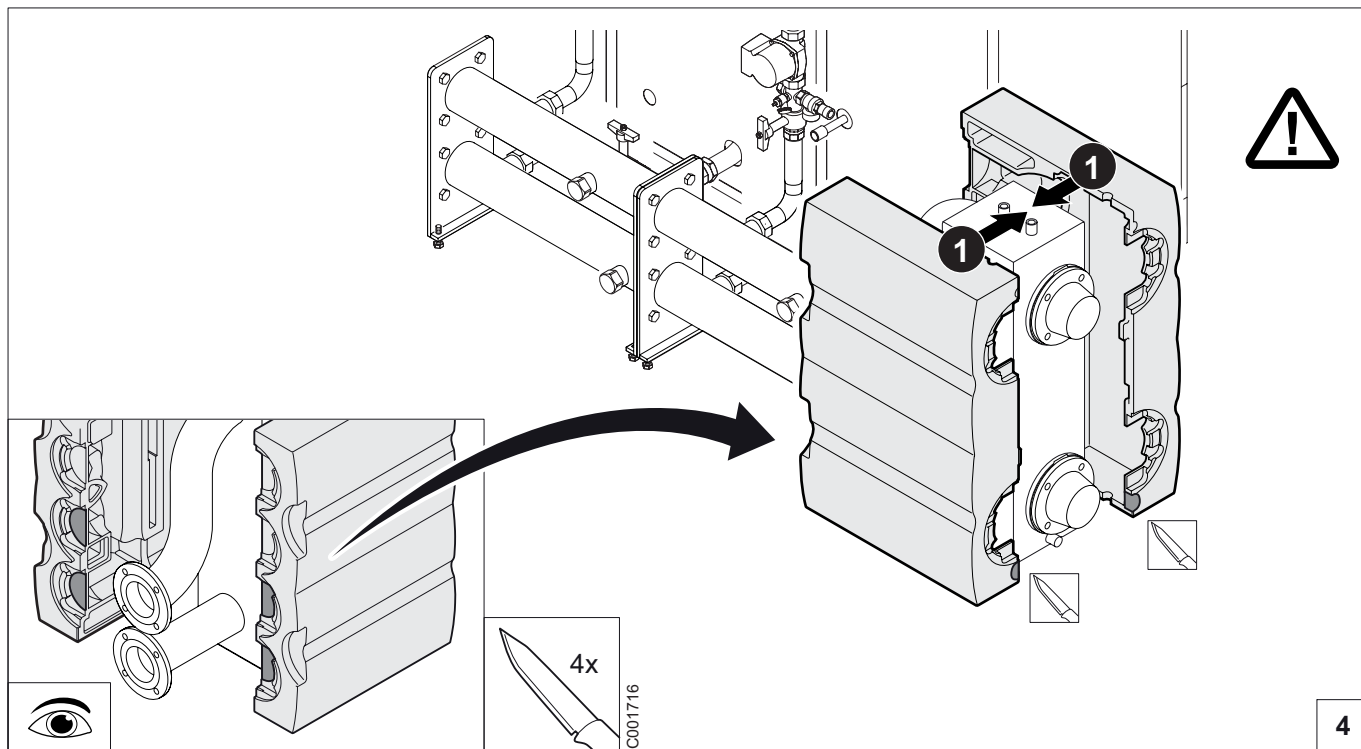

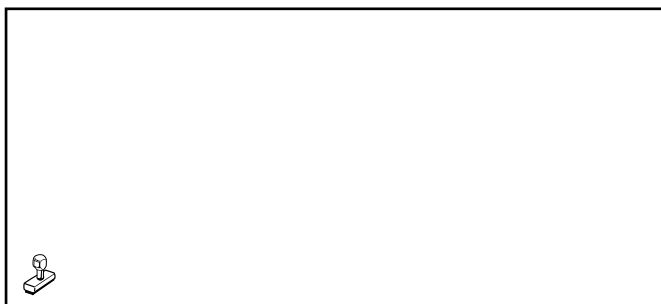

DE DIETRICH THERMIQUE
57, rue de la Gare F- 67580 MERTZWILLER - BP 30
www.dedietrich-heating.com

AD051-AA

Sous réserve de modifications

Salvo modifichie

Änderungen vorbehalten

A reserva de modificaciones

Subject to alterations

Zastrzega się możliwość zmian technicznych

Wijzigingen voorbehouden

Возможны изменения



300016422-001-B

12/03/08