

EXPLODED DIAGRAM

► AIR 29 C12A

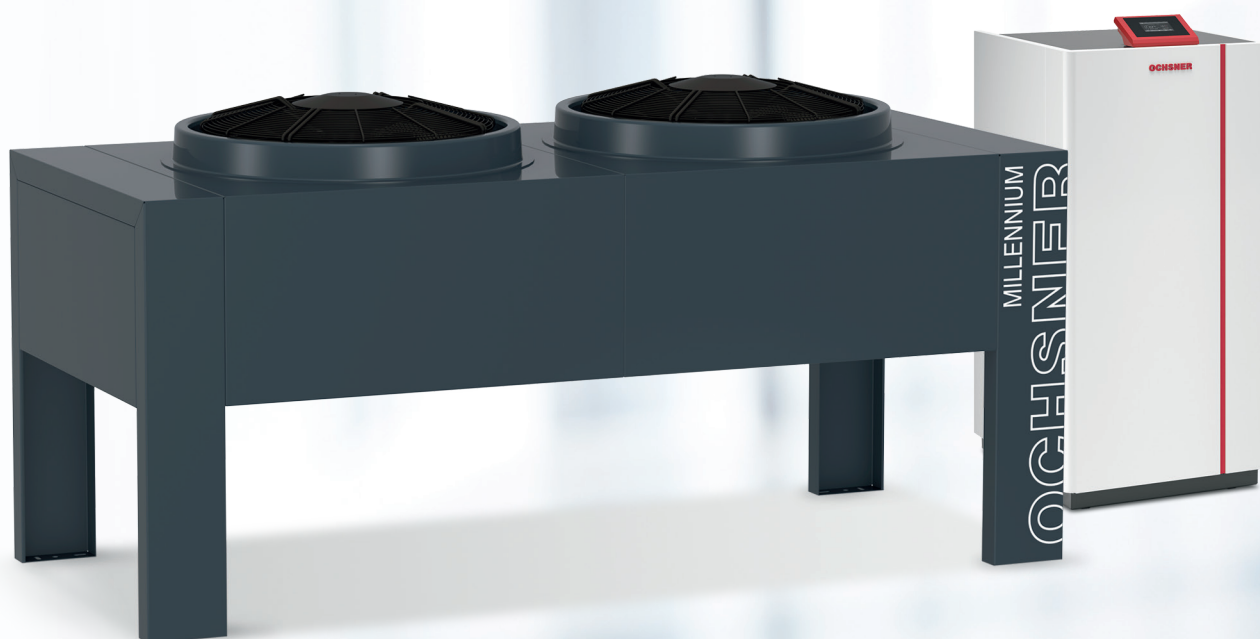

TRANSLATION OF THE ORIGINAL MANUAL

OCHSNER
WÄRMEPUMPEN

CONTENTS

INDOOR UNIT

1.	Appliance casing	3
2.	Maxi terminal	4
3.	Casing frame	5
4.	Refrigerant circuit overview	6
5.	Suction gas line 1	7
6.	Suction gas line 2 + 3	8
7.	Pressure line 1	9
8.	Pressure line 2	10
9.	OVI circuit assembly	11
10.	Liquid line 1	13
11.	Liquid line 2	14
12.	Mounting rail	15
13.	WNA flow and return	16

OUTDOOR UNIT

14.	Appliance casing	18
14.1	Special colours for the outdoor unit	18
15.	Components	19
16.	Expansion valve assembly	20

ELECTRICS

17.	Electrics AIR 29 C12A	21
-----	-----------------------	----

ACCESSORIES

18.	Connection line	22
19.	Controller sensor set	22
20.	Evaporator sensor set	22
21.	OTE sensors	22
22.	Surcharge, heating/cooling	22
23.	OTE Modbus interface (optional)	22
24.	Electricity meter retrofit	22
25.	Accessories (optional)	22
26.	Accessories for outdoor unit (optional)	22
27.	OTE controller accessories	22
28.	Log book	22

TECHNICAL SPECIFICATIONS

29.	Medium specification	23
30.	Compressor specification	23

CHANGE OVERVIEW FOR LATEST VERSION

INDOOR UNIT

1. Appliance casing

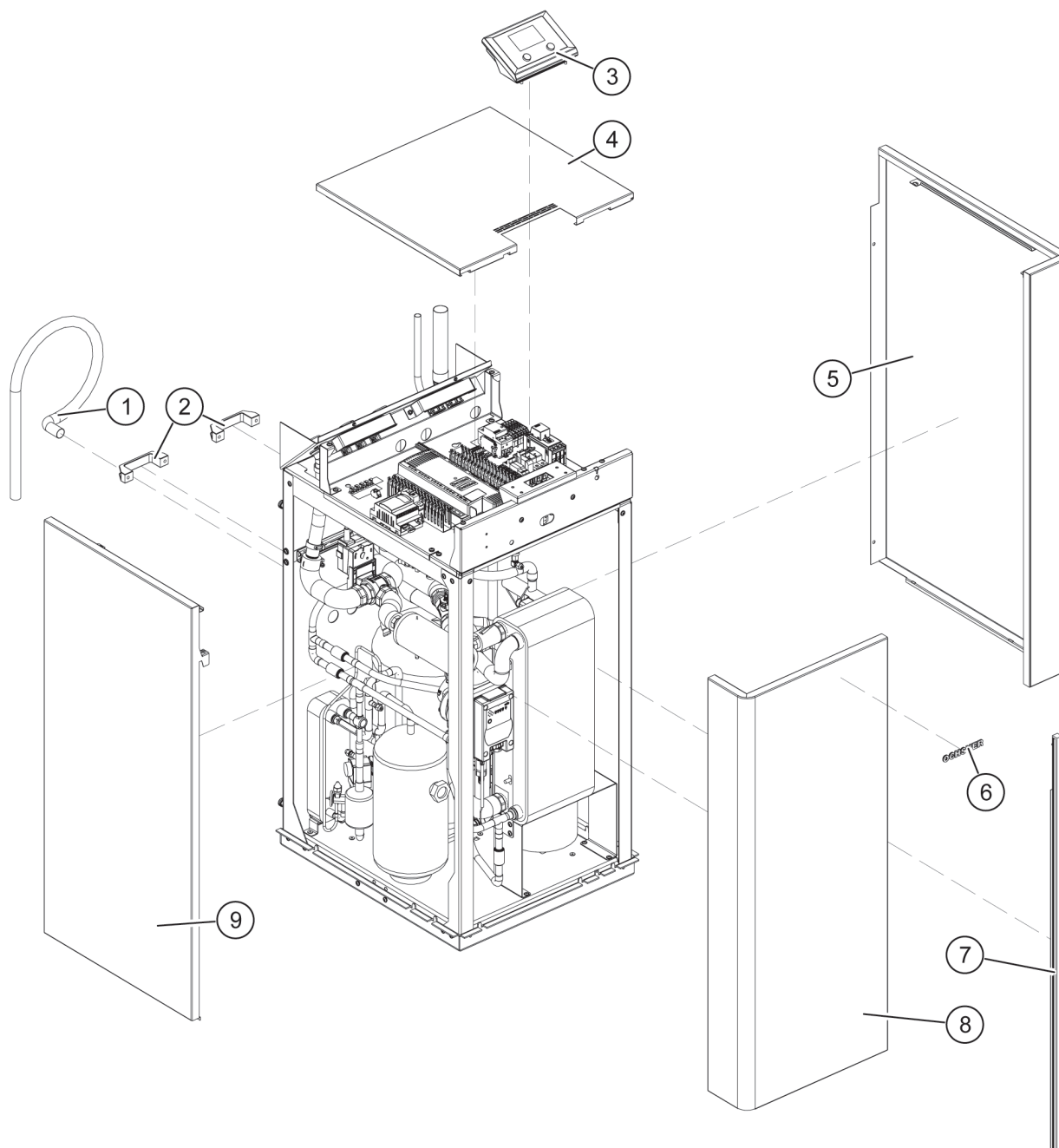

OCH_08_09_200_202_002_001

Key	Part number	Designation
1	922781	Drain hose, L 2 m
2	916471	Strap grip
3	x	Maxi terminal (see page 4, Maxi terminal)
4	915641	Top cover M2/M4 RAL 7016 matt
5	991289	Side section right M2/M4
6	916475	"Ochsner" logo
7	916540	Plexiglass strip M2/M4 red

Key	Part number	Designation
8	991287	Front panel M2/M4
9	991288	Side section left M2/M4

2. Maxi terminal

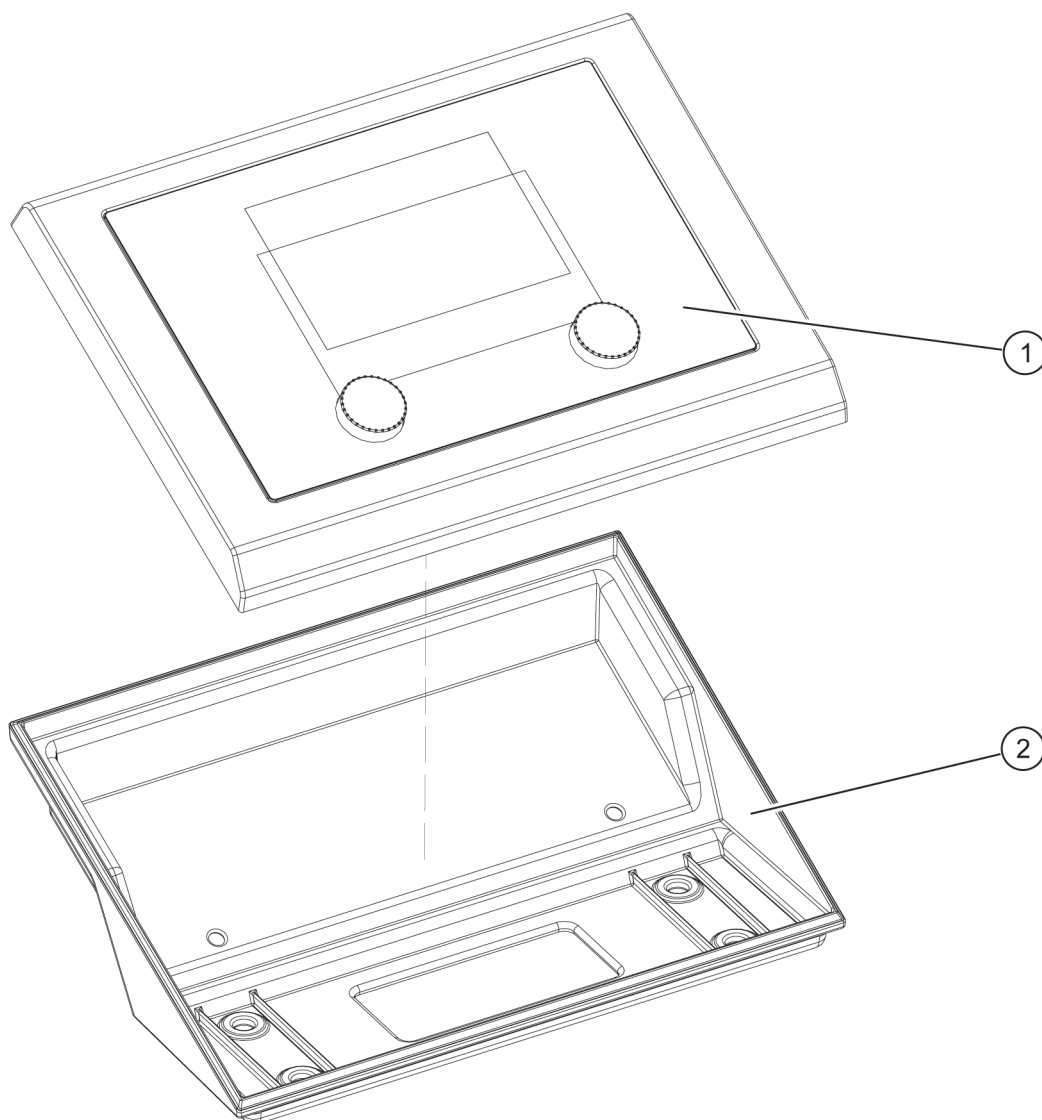

OCH_08_06_200_202_002

Key	Part number	Designation
1	918334	User interface, master remote control
2	916436	User interface, rear panel
2.1	923287	Round head screw M6 x 16 mm

3. Casing frame

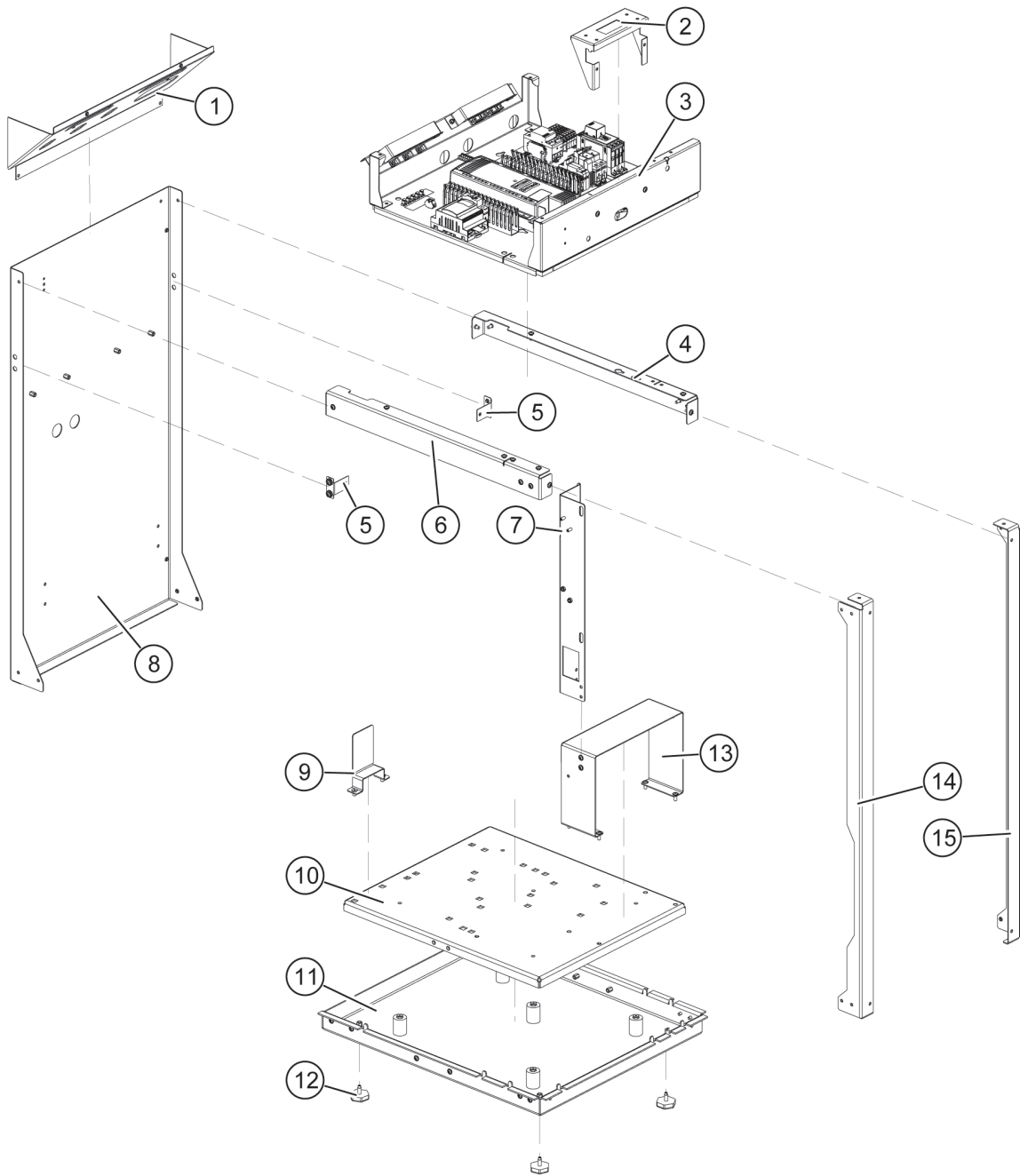

OCH_08_06_200_002_002_002

Key	Part number	Designation
1	915755	Back panel, hydraulic connection plate
2	915713	Maxi touchscreen bracket
3	915637	Maxi control box base plate
4	915742	Base frame strut, top right
5	915966	Mounting rail bracket M2/M4
6	915743	Maxi base frame strut, top left
7	915708	Maxi bracket condenser 2
8	915939	Back panel M2/M4
9	915749	ECO bracket M2/M4
9.1	917523	Rubber support for ECO bracket 135 x 70 mm

Key	Part number	Designation
9.2	923336	Flat head screw M8 x 12 mm
10	915883	Maxi mounting plate base
11	915878	Maxi base plate
11.1	916494	Rubber buffer fem./fem. M8
11.2	923166	Captive nut M8
12	916458	Universal slider
13	915707	Maxi bracket condenser 1
14	915741	Base frame strut, front left
15	915742	Base frame strut, front right
	923373	Fixing strap set (transport aid)

4. Refrigerant circuit overview

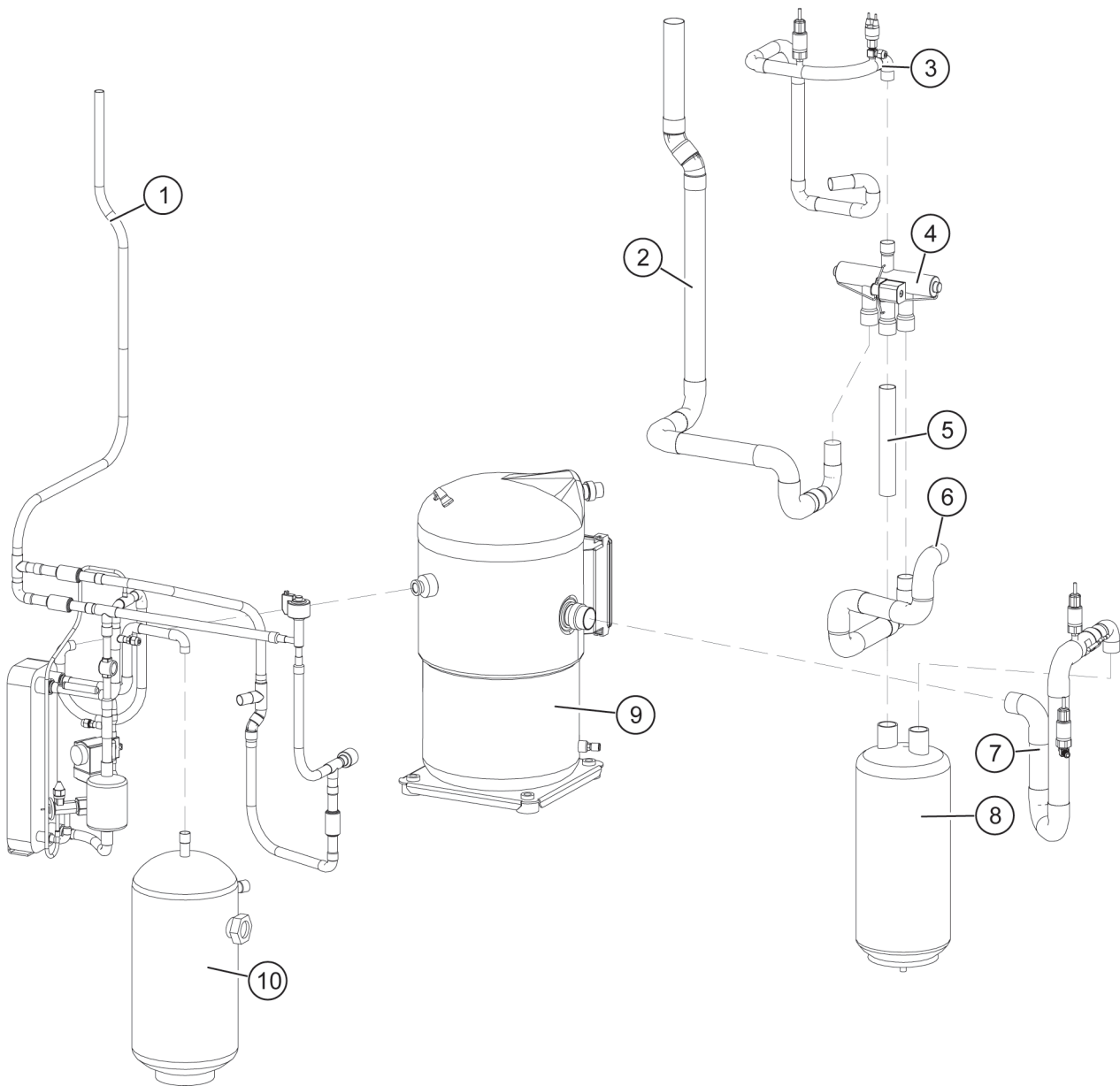

OCH_08_09_200_202_002_002_003

Key	Part number	Designation
1	x	Liquid line (see page 11, OVI circuit assembly)
	x	Liquid line (see page 13, Liquid line 1)
	x	Liquid line (see page 14, Liquid line 2)
2	x	Suction gas line 3 (see page 8, Suction gas line 2 + 3)
3	x	Pressure line 1 (see page 9, Pressure line 1)
4	992122	Assembly, 4-way valve
4.1	912292	Solenoid valve 4-way STF0715G3
4.2	912514	Solenoid valve coil 4-way valve
5	x	Suction gas line 2 (see page 8, Suction gas line 2 + 3)
6	x	Pressure line 2 (see page 10, Pressure line 2)

Key	Part number	Designation
7	x	Suction gas line 1 (see page 7, Suction gas line 1)
8	912478	Fluid separator ESK FA-28-5,7I
8.1	917450	Insulation for fluid separator
9	910125	Compressor ZH24 KVE-TWD-526
9.1	910103	Compressor motor protection INT 69 SC2
10	912600	Liquid receiver 7.8 l with sight glass

5. Suction gas line 1

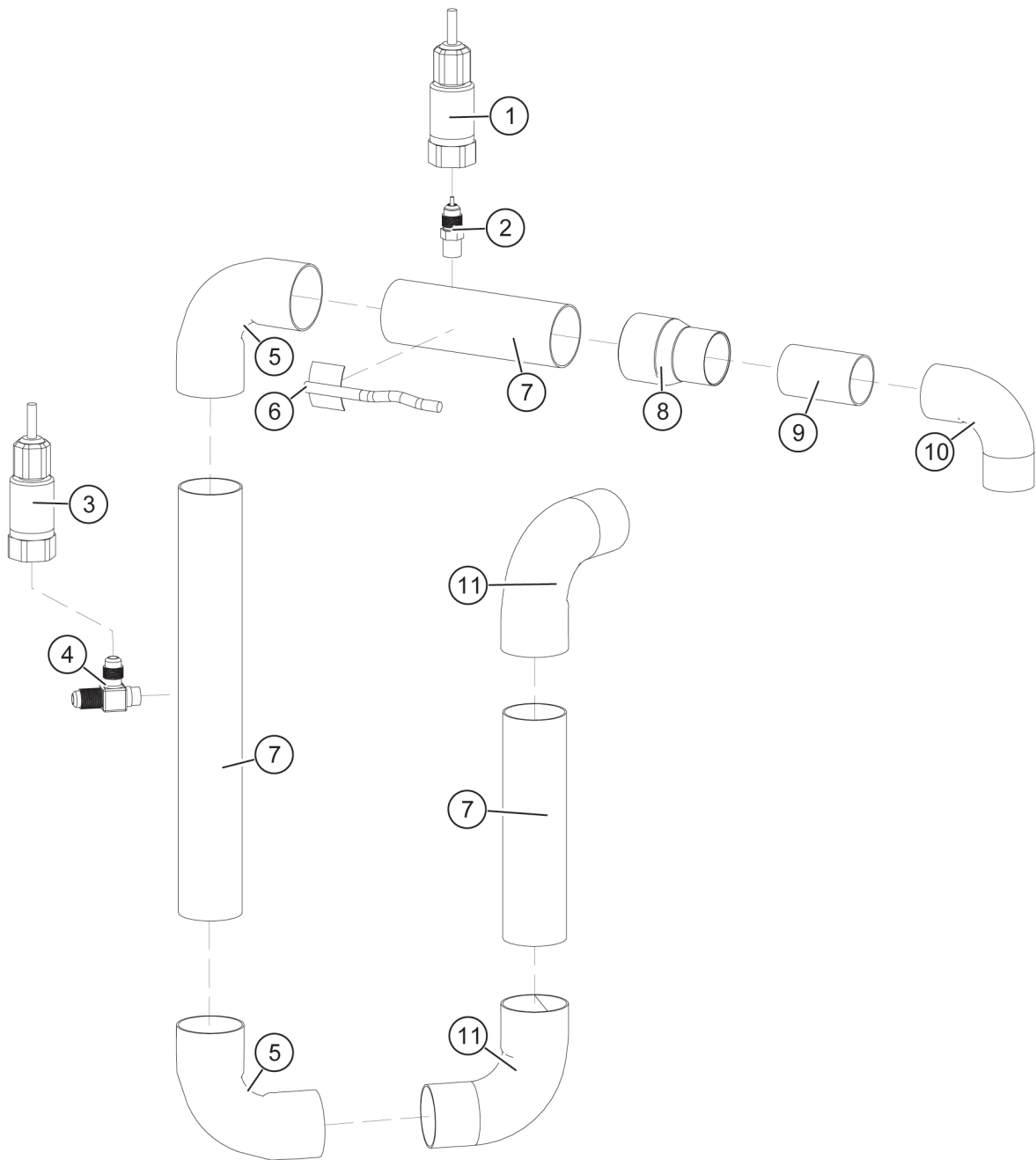

OCH_08_09_200_202_002_002_004

Key	Part number	Designation
1	930306	Pressure sensor HP+LP 0.0-34.5 bar
1.1	918469	Cable quick release fitting
1.2	912449	Copper sealing ring 6 mm 1/4"
2	912638	Fill valve single
2.1	912589	Insert for fill valve, blue seal ring
3	930305	Pressure transmitter S3, 25 bar
3.1	918469	Cable quick release fitting
3.2	912449	Copper sealing ring 6 mm 1/4"
4	912639	Fill valve double
4.1	912589	Insert for fill valve, blue seal ring
5	913032	Copper bend 90°, 35 mm, f/f, 5002A

Key	Part number	Designation
6	930315	Contact temperature sensor NTC 5 K
7	x	Copper pipe 35 x 2 mm
8	913119	Reducing socket 35 x 28 mm (f/f), 5240
9	x	Copper pipe 28 x 1.5 mm
10	913004	Copper bend 90° 28 mm f/m 5001A
11	913031	Copper bend 90°, 35 mm, f/m, 5001A

7. Pressure line 1

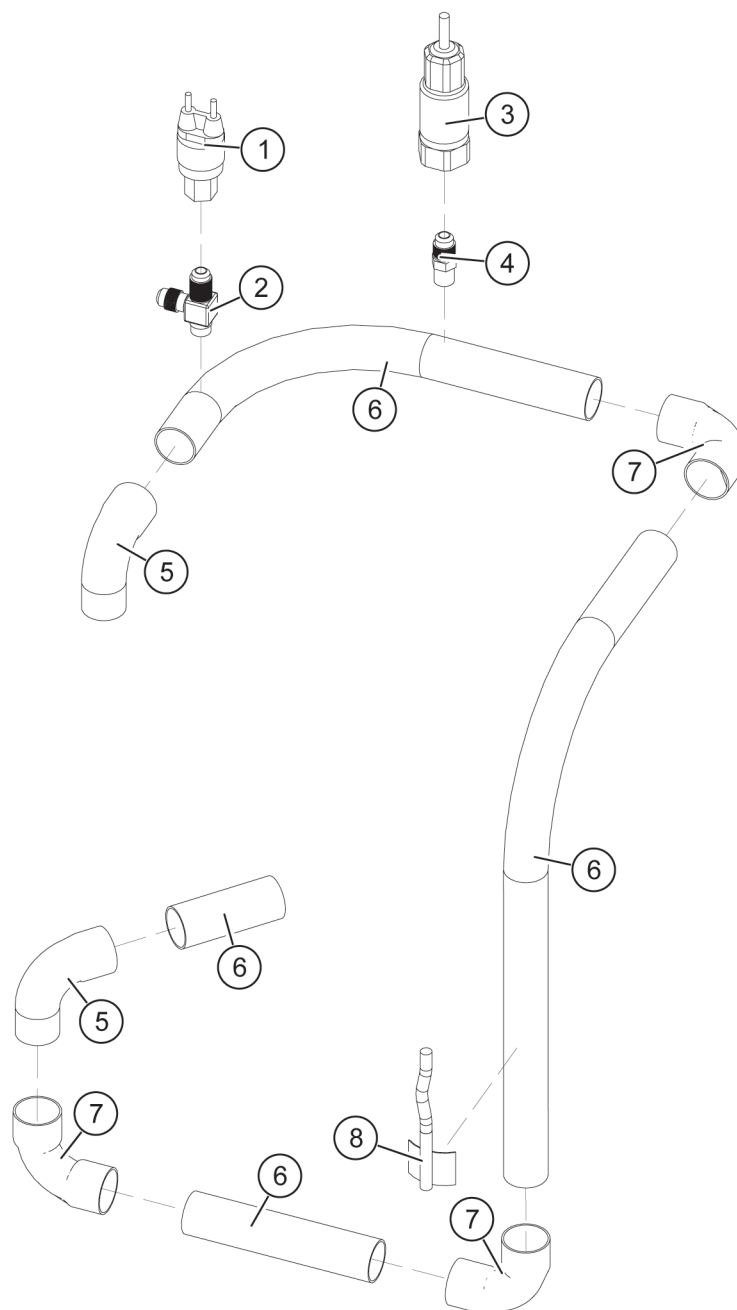

OCH_08_09_200_202_002_002_006

Key	Part number	Designation
1	930228	Pressure switch cartridge 25 - 30 bar, ACB-2UB220W
1.1	912449	Copper sealing ring 6 mm 1/4"
2	912639	Fill valve double
2.1	912589	Insert for fill valve, blue seal ring
3	930306	Pressure sensor HP+LP 0.0-34.5 bar
3.1	918469	Cable quick release fitting
3.2	912449	Copper sealing ring 6 mm 1/4"
4	912638	Fill valve single
4.1	912589	Insert for fill valve, blue seal ring
5	913035	Copper bend 90° 22 mm f/m 5001A

Key	Part number	Designation
6	x	Copper pipe 22 x 1 mm, R220
7	913019	Copper bend 90°, 22 mm, f/f, 5002A
8	930315	Contact temperature sensor NTC 5 K

8. Pressure line 2

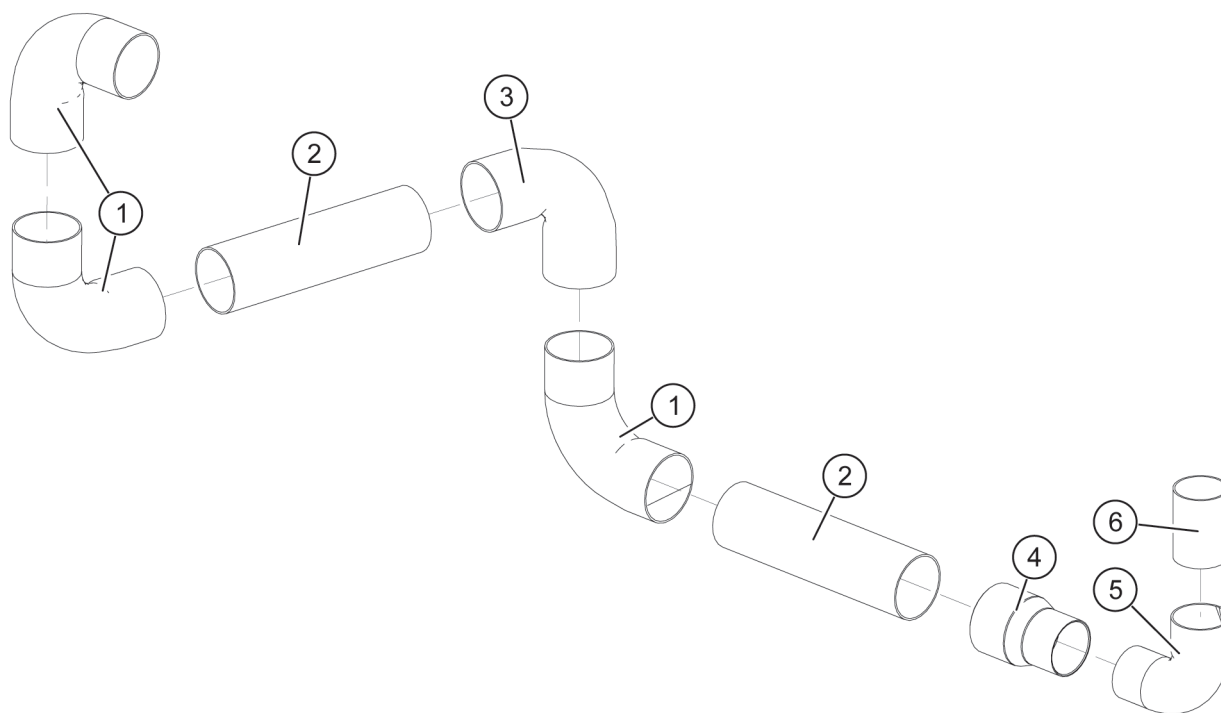

OCH_08_09_200_202_002_002_007

Key	Part number	Designation
1	913031	Copper bend 90°, 35 mm, f/m, 5001A
2	x	Copper pipe 35 x 2 mm
3	913032	Copper bend 90°, 35 mm, f/f, 5002A
4	913119	Reducing socket 35 x 28 mm (f/f), 5240
5	913004	Copper bend 90° 28 mm f/m 5001A
6	x	Copper pipe 28 x 1.5 mm, R290

9. OVI circuit assembly

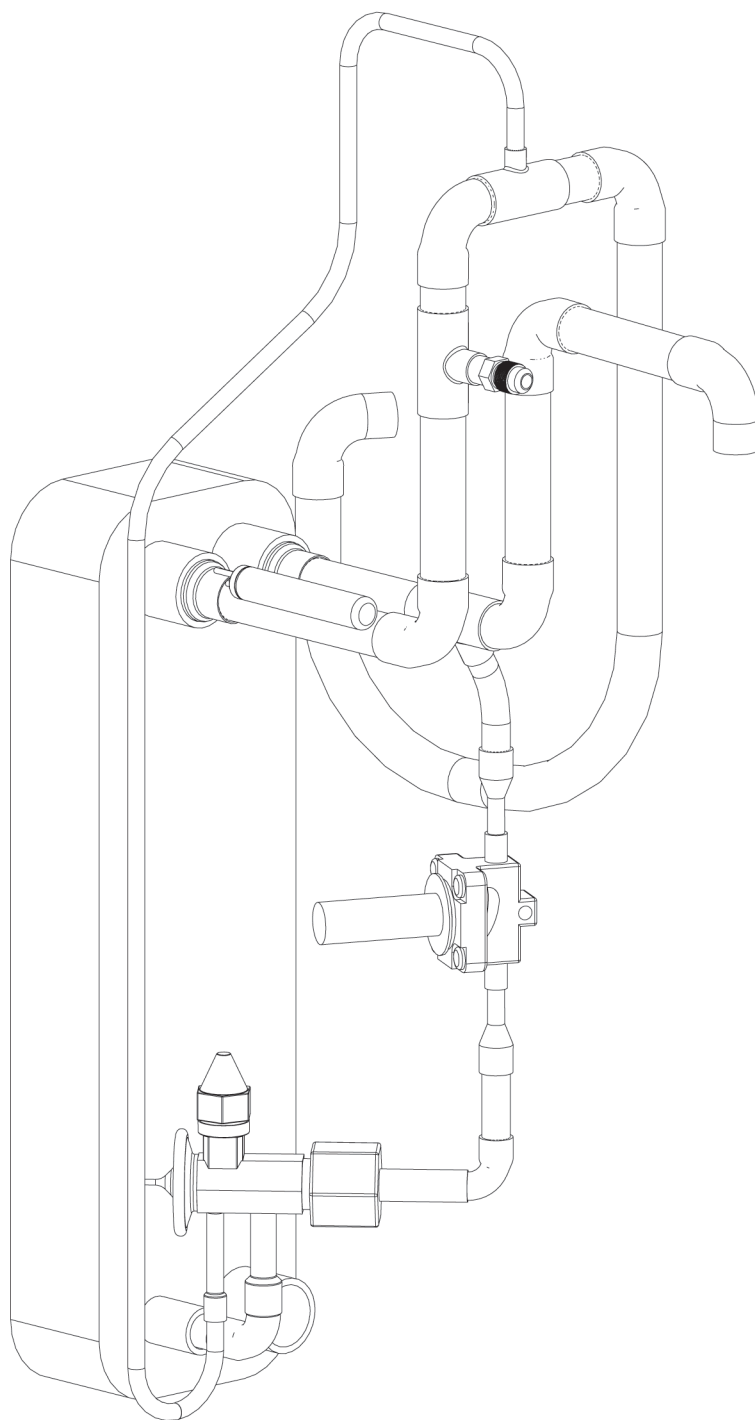

OCH_08_09_200_202_002_002_008

Part number	Detailed designation
991829	Assembly, OVI circuit AIR 29
913047	Copper pipe 12 x 1 mm, R220
913052	Copper pipe 16 x 1 mm, R220
913048	Copper pipe 10 x 1 mm R220
913049	Copper pipe 6 x 1 mm, R220
913208	Tee 16 x 10 x 16 mm
911314	Plate heat exchanger AC-30EQ-24H-G

Part number	Detailed designation
912773	Solenoid valve without coil, EVR 3, 10 mm soldered
912774	Coil for solenoid valve 12 W, 230 V, 50/60 Hz
912638	Fill valve, single
912931	Sealing cap for fill valve, 7/16" UNF
9120155	Filter dryer DTG-B08050-901
912971	Sight glass 16 mm, SYJ16H11
913085	Tee 16 x 16 x 16 mm

EXPLODED DIAGRAM | OVI circuit assembly

Part number	Detailed designation
913116	Reducing nipple 22 x 16 mm, (m/f), 5243
913010	Tee 16 x 6 x 16 mm, 5130
912413	Thermostatic valve for EVI, TMVXBL-E0684 R407C +30/-30°C
9220375	Silicone hose 50 mm, slotted, NW 6 x 2 mm
912464	Nozzle 1.5 mm
912335	Solder adaptor 10 mm
930163	Sensor clip 190 mm
913016	Copper bend 90°, 10 mm, f/m, 5001A
913017	Copper bend 90°, 12 mm, f/m, 5001A
913037	Copper bend 90°, 16 mm, f/m, 5001A
913030	Copper bend 90°, 16 mm, f/f, 5002A

10. Liquid line 1

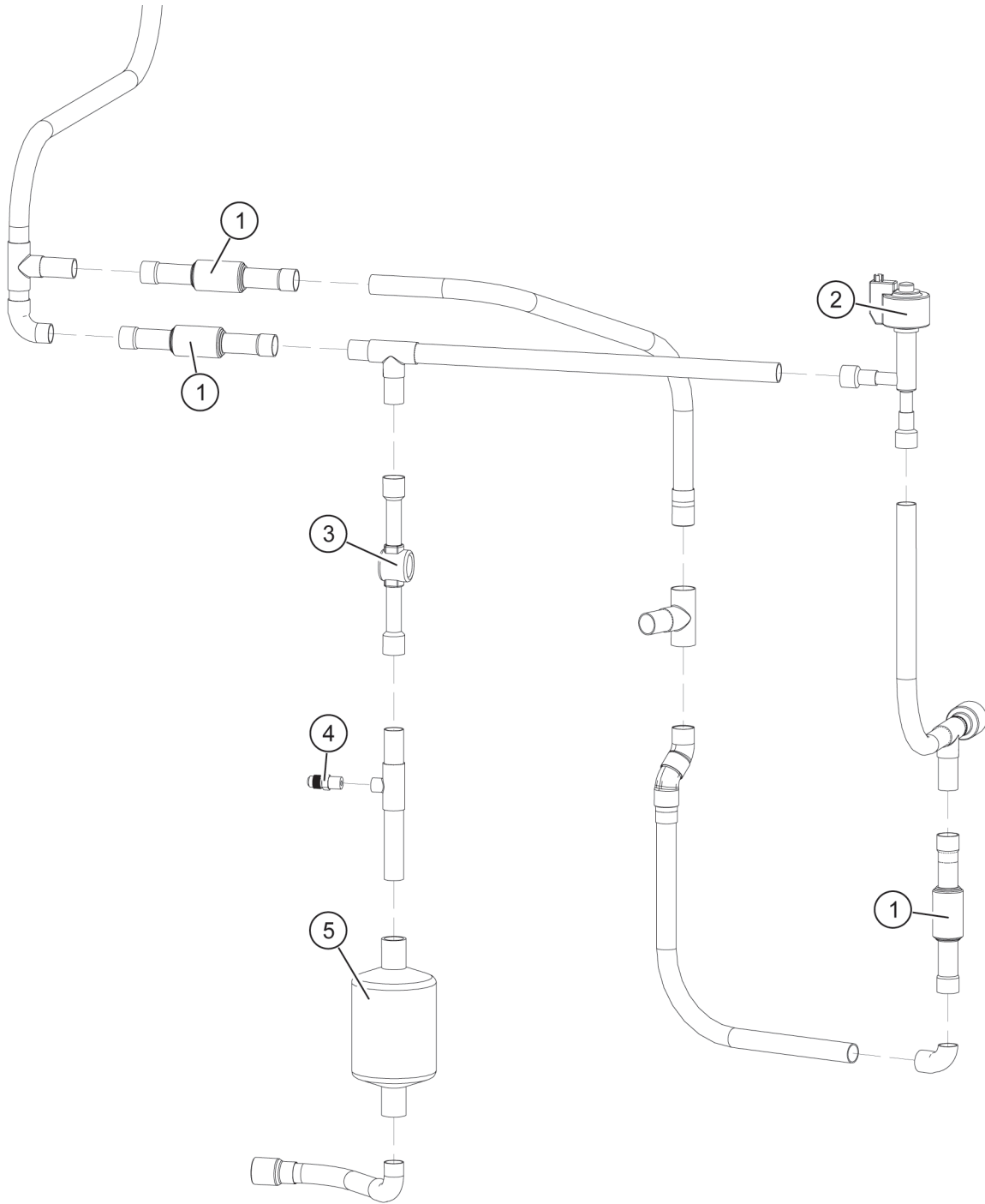

OCH_08_09_200_202_002_002_009

Key	Part number	Designation
1	912262	Non-return valve NRV 12s, 16 mm soldered
2	912765	Expansion valve E3V45SSR10 including stepper motor
2.1	9120775	Stepper motor for thermostatic valve electronic
2.2	9120441	Connecting cable with plug for stepper motor
3	912971	Sight glass 16 mm, SYJ16H11
4	912638	Fill valve single
4.1	912589	Insert for fill valve, blue seal ring

Key	Part number	Designation
4.2	912931	Sealing cap for fill valve, 7/16" UNF
5	9120155	Filter dryer DTG-B08050-901

11. Liquid line 2

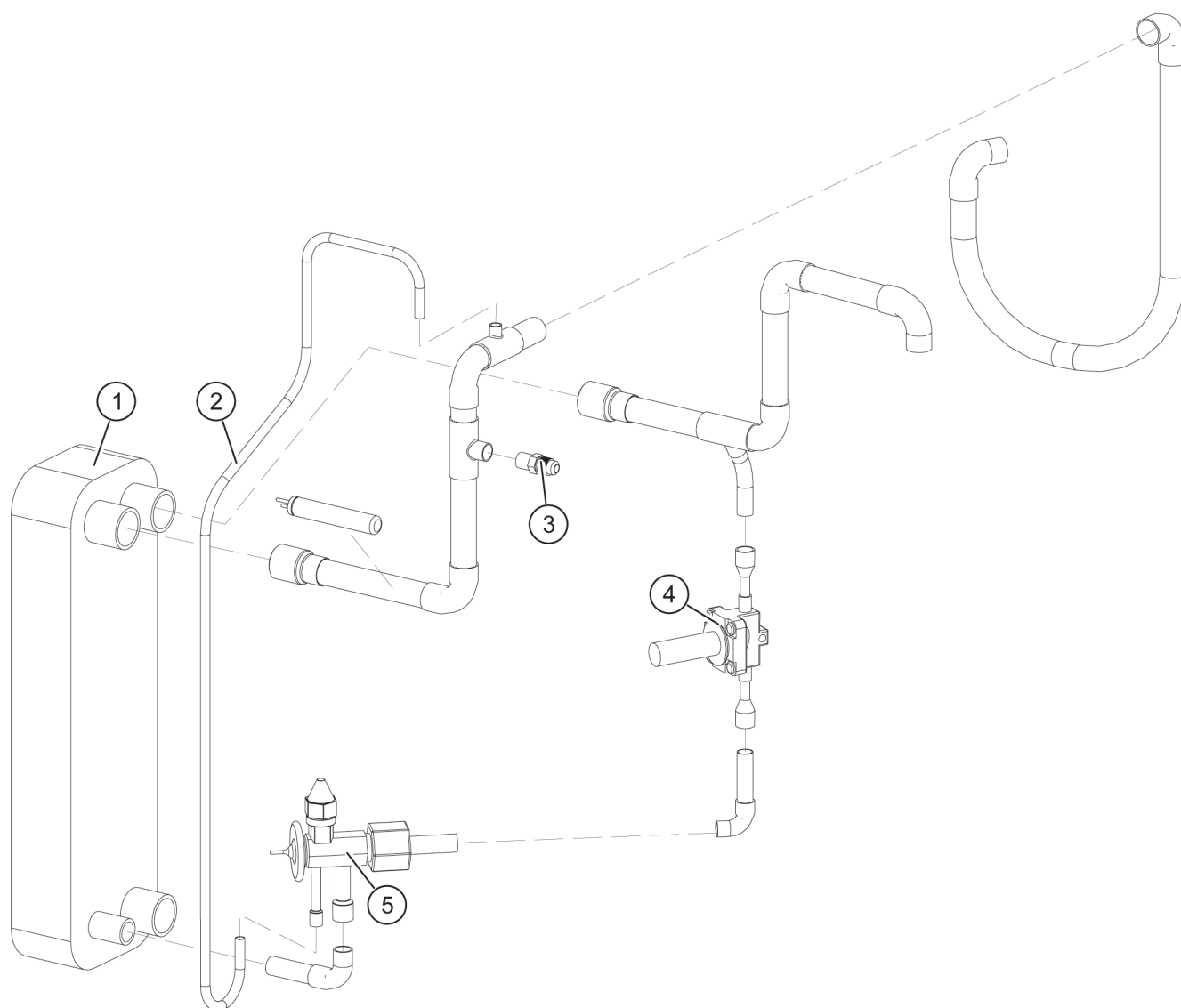

OCH_08_09_200_202_002_002_010

Key	Part number	Designation
1	911314	Plate heat exchanger AC-30EQ-24H-G
2	913049	Copper pipe 6 x 1 mm, R220
3	912638	Fill valve single
3.1	912589	Insert for fill valve, blue seal ring
4	912773	Solenoid valve without coil, EVR 3, 10 mm soldered
4.1	912774	Coil for solenoid valve 12 W, 230 V, 50/60 Hz
5	912413	Thermostatic valve for EVI, TMVX-BL-E0684 R407C +30/-30°C
5.1	912464	Nozzle 1.5 mm
5.2	912335	Solder adaptor 10 mm
5.3	930163	Sensor clip 190 mm

12. Mounting rail

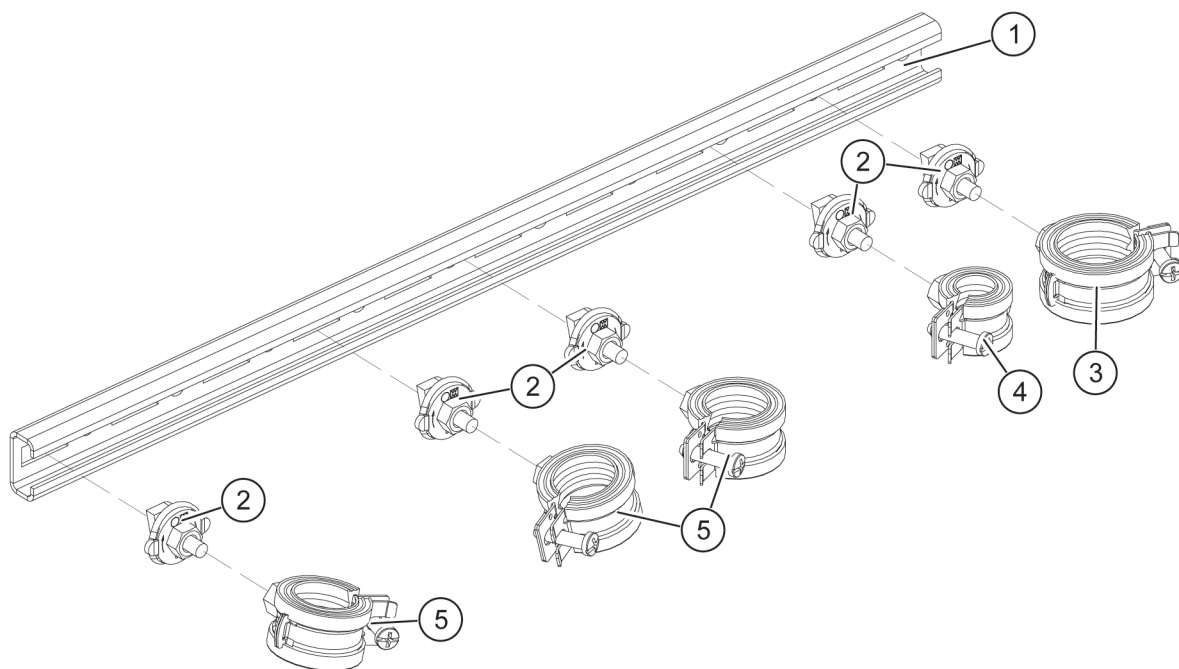

Key	Part number	Designation
	923340	Assembly, mounting rail 18 - 35 mm
1	923332	Mounting rail 0.5 m galvanised
1.1	923465	Fixing screw M6 x 10 mm
2	923333	Fixing screw M8
3	9220069	Pipe clamp 31 - 35 mm M8
4	9220066	Pipe clamp 15 - 18 mm M8
5	922776	Pipe clamp 25 - 28 mm M8

13. WNA flow and return

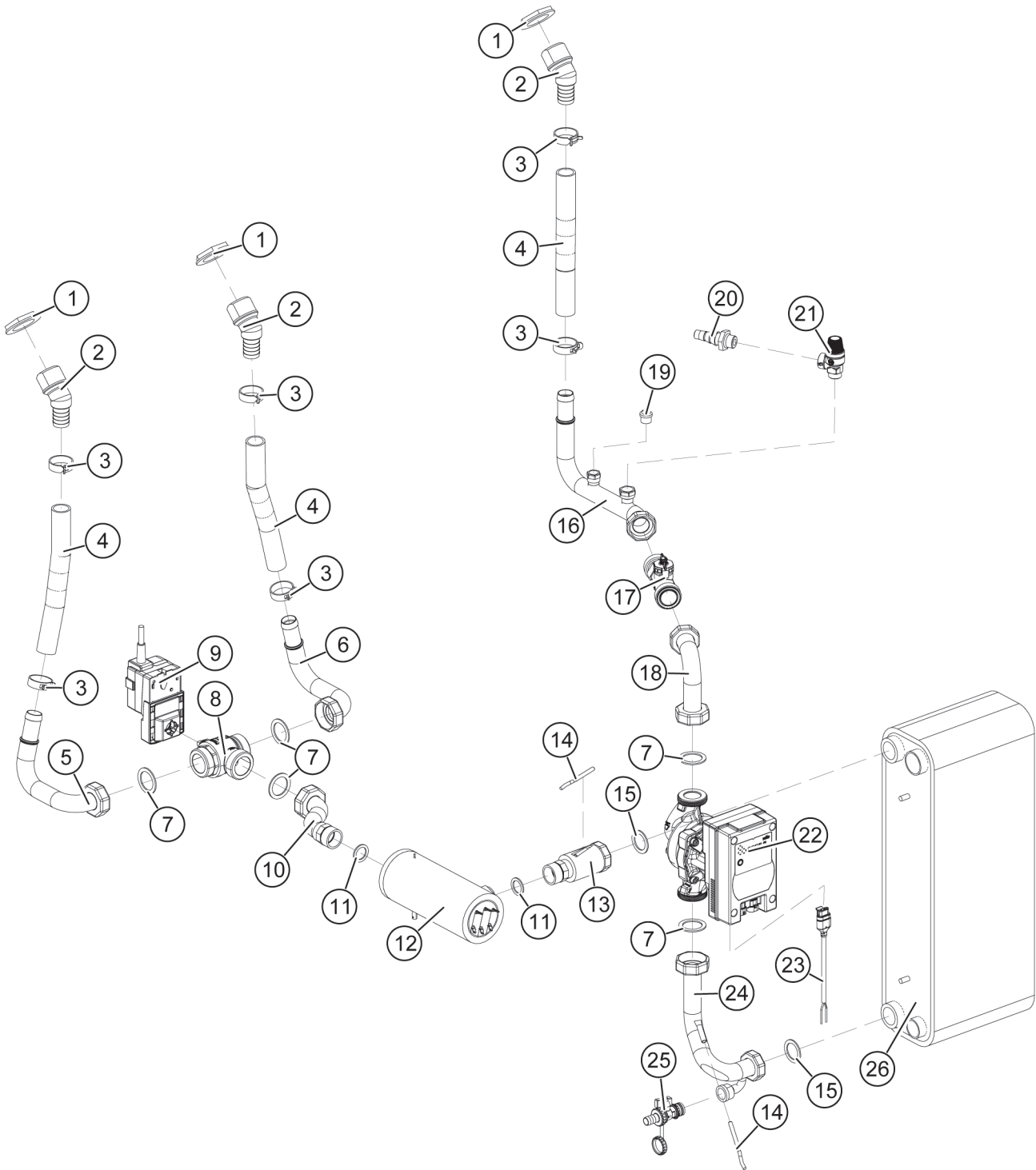

OCH_06_09_200_202_002_002_012

Key	Part number	Designation
1	913535	Hexagon nut 5/4", 5000OT series
2	914421	Connecting bend 5/4", 45°
3	922735	Hose clip – spring band clamp
4	916477	Pressure hose, L 210 mm
5	922774	Pipe assembly WNA flow 4 M4
6	922773	Pipe assembly flow 3 M4
7	916493	Flat gasket AFM34 - 44 x 32 x 2 mm

Key	Part number	Designation
8	922954	3-way valve DN 32 without servomotor
9	9220203	3-point actuator, LX90-F015 OCS
9.1	922966	Connecting cable for 3-point actuator
10	922713	Pipe assembly WNA flow 2 M4 - with electric immersion heater, with 3-way valve
	922783	Pipe assembly WNA flow M4 - without electric immersion heater, without 3-way valve

EXPLODED DIAGRAM | WNA flow and return

Key	Part number	Designation
	922784	Pipe assembly WNA flow M4 - without electric immersion heater, without 3-way valve
	922785	Pipe assembly WNA flow M4 - with electric immersion heater, without 3-way valve
11	916310	Klingerit gasket 30 x 21 x 2 mm
12	980190	Assembly, electric immersion heater 8.8 kW including circlip, union nut 1" and insulation Note: no longer applicable since Q1 2023
12.1	9290177	Connecting cable for electric immersion heater 4 x 2.5 mm ²
13	922712	Pipe assembly WNA flow 1 M4 - with electric immersion heater, with 3-way valve
14	930232	Cable temperature sensor OTE 4.0 m, NTC 5K, -40°C to 130°C, IP 68
15	916074	Klingerit gasket 39 x 28 x 2 mm
16	922709	Pipe assembly WNA return 3 M4
17	918327	Flow sensor DN25, 0-10 V, 9 - 150 l/min
17.1	918504	O-ring gasket for flow sensor
18	922708	Pipe assembly WNA return 2 M4
19	914015	Plug, gunmetal 3/8"
20	916456	Hose nozzle 1/2"
21	922806	Safety valve 3 bar – 1/2" male/fem.
	9500020	Assembly, energy saving pump comprising
22	9220206	Energy saving pump Para MAXO-G 25-180-08-F02-D06, WITHOUT power cable
22.1	916493	Flat gasket 44 x 32 x 2 mm
23	9220220	Power cable for Para MAXO, 3 x 0.75 mm ² , L 2000 mm
24	922707	Pipe assembly WNA return 1 M4
25	914347	Fill/drain valve, 1/2"
26	991285	Assembly, condenser CB62-90AHDS-G
26.1	911602	Plate heat exchanger CB62-90AHDS-G
26.2	917335	Insulation for CB62-90

OUTDOOR UNIT

14. Appliance casing

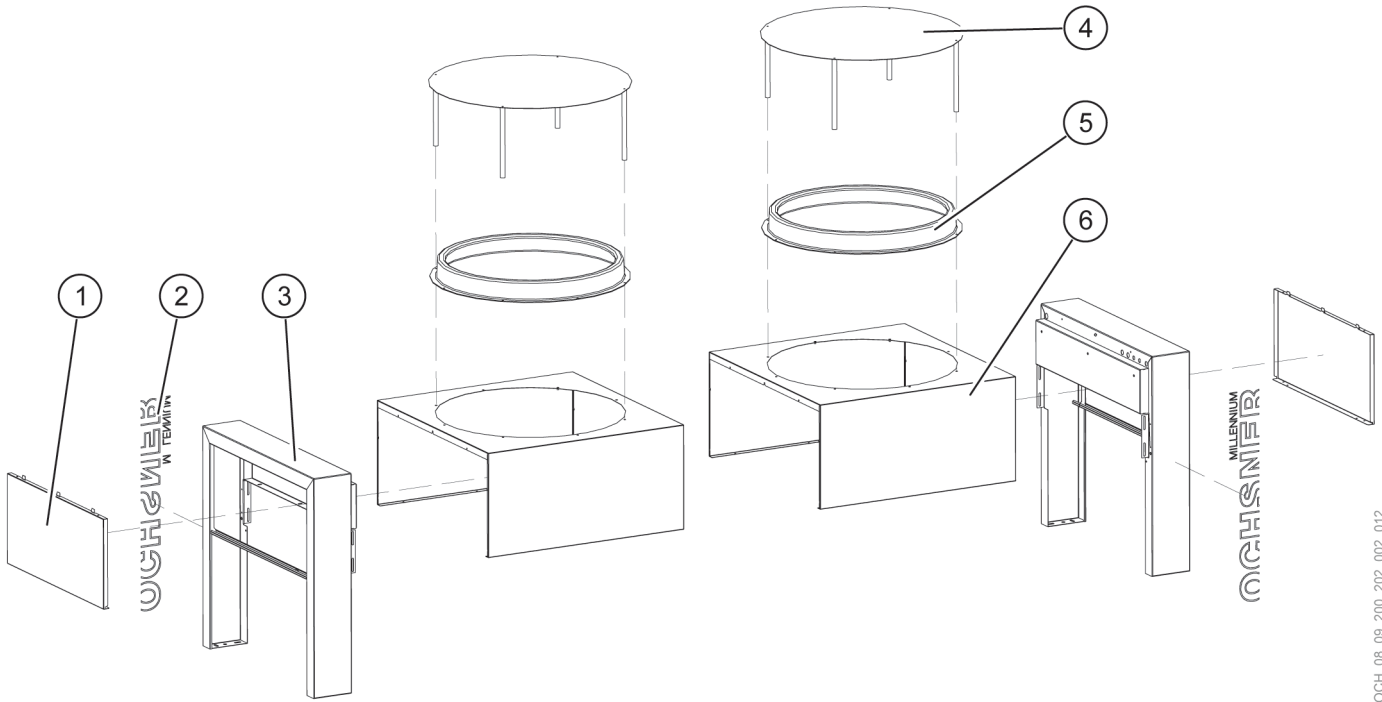

OCH_06_09_200_202_002_012

Key	Part number	Designation
1	915593	Side cover RAL 7016
	915610	Side cover RAL 9016
1.1	916629	Frame buffer 8 mm
2	919183	Label, white, for RAL 7016
	919202	Label, grey, for RAL 9016
3	991024	Base VHS-M RAL 7016, with label applied, white
	x	Base VHS-M RAL 9016, with label applied, grey
4	915763	Snow cover set 2017 RAL 7016
	915795	Snow cover set 2017 RAL 9016
5	932033	Reducer ring complete RAL 7016
	932034	Reducer ring complete RAL 9016
6	915590	Cowl RAL 7016
	915611	Cowl RAL 9016

14.1 Special colours for the outdoor unit



Note

The spare parts numbers in this documentation relate to standard colours RAL 7016 “anthracite grey” and RAL 9016 “traffic white”.

If a special colour was used for the outdoor unit and you require a spare part in this special colour, please email us.

Your email should include the following details:

- ▶ Name
- ▶ Address
- ▶ Serial number of the indoor unit and outdoor unit
- ▶ Spare part required

15. Components

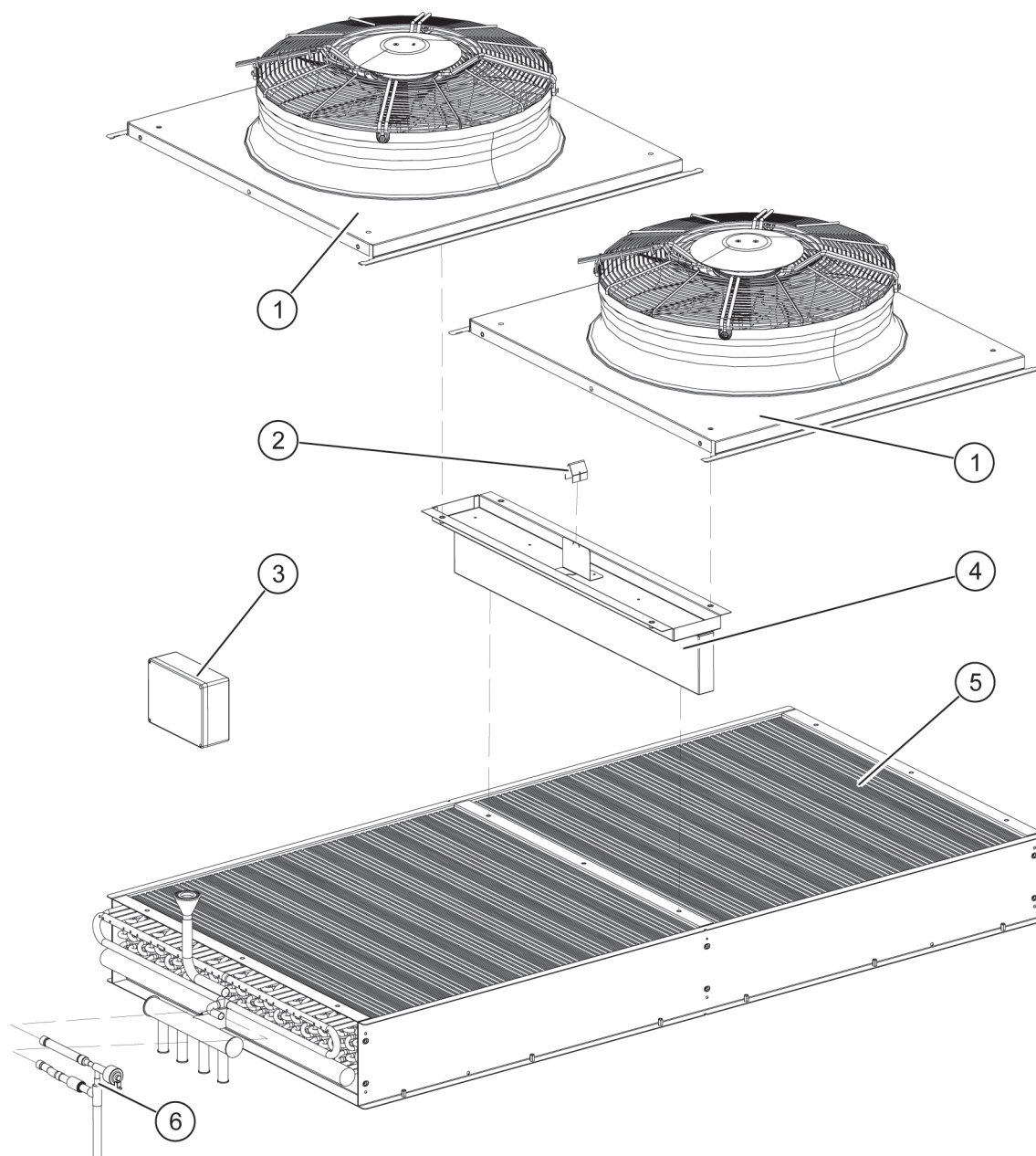

Key	Part number	Designation
1	931076	Fan W3G630-GD05-50-DB – fan being phased out
	931115	Fan W3G630-GL06-G4 – fan new
	931137	Fan WEI.EC102/50E3G01-AS630/82P1-02-B1 - fan alternative
2	915617	Spacer for cowl
3	929865	Terminal strip enclosure for VHS-M – Carel version
4	915592	Centre support, stainless steel plate 1.0 mm
5	912613	Evaporator fins for VHS-M 25
6	x	Expansion valve assembly VHS-M 25 / EEV Carel (see page 20, Expansion valve assembly)

16. Expansion valve assembly

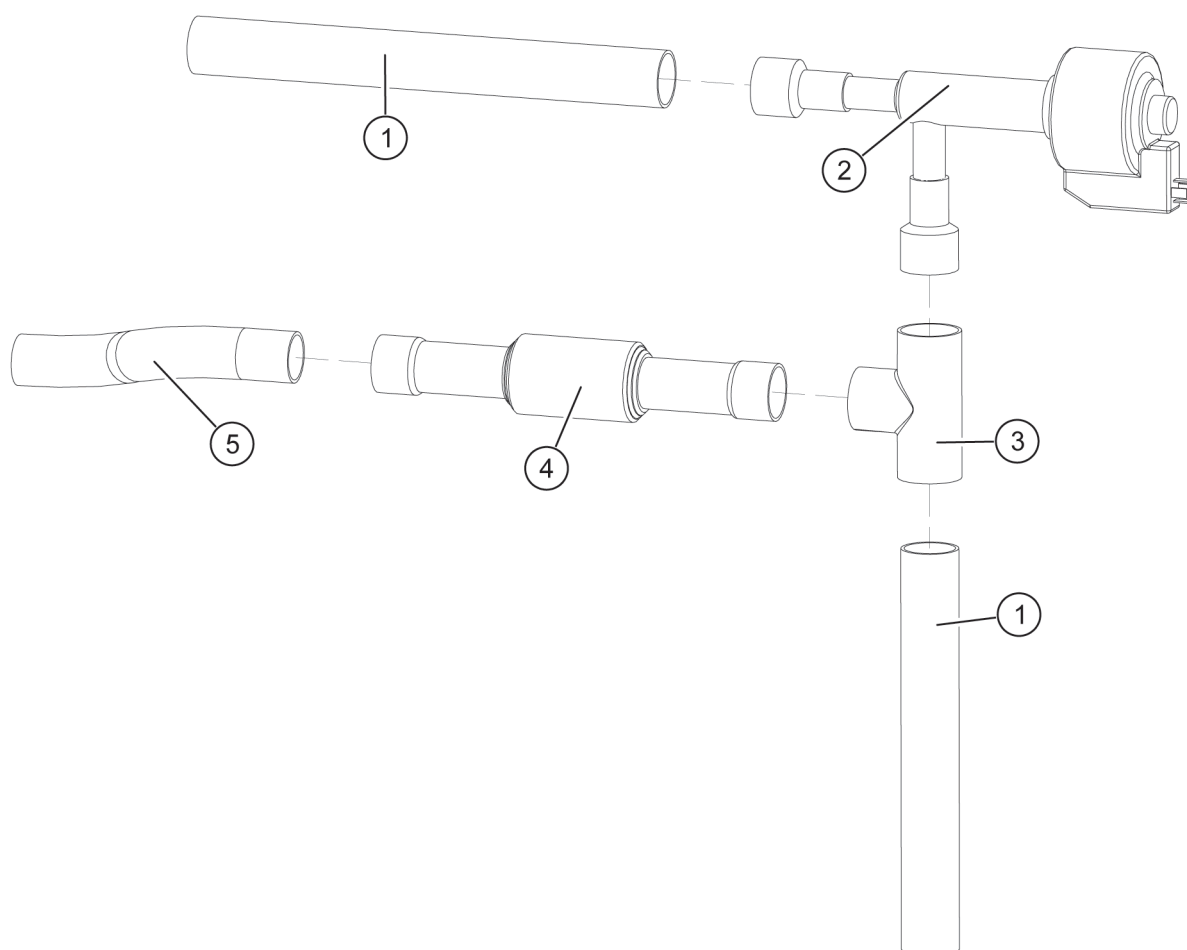

OCH_08_08_200_202_001

Key	Part number	Designation
	990938	Expansion valve assembly VHS-M 25 / EEV Carel
1	x	Copper pipe 18 x 1 mm
2	9120698	Expansion valve E2V35FSMC1 without stepper motor
2.1	9120440	Stepper motor for thermostatic valve electronic
2.2	9120441	Connecting cable with plug for stepper motor
3	913107	Copper tee 18 mm, 3150
4	912262	Non-return valve NRV 12s, 16 mm soldered
5	x	Copper pipe 16 x 1 mm

ELECTRICS

17. Electrics AIR 29 C12A

Part number	Detailed designation
918204	Controller WPC OTE plus 3.0
9290128	Control box AIR M2/M4
915637	Maxi control box base plate
915713	Maxi touchscreen bracket
915714	Cable entry Maxi DC01 EVZ25
917527	Safety guard 160 x 20 x 20 mm
9290698	Cable tie mounting base
922679	Cover clip, clamping range 3 - 23 mm
9290681	Top-hat profile rail with drilled holes TS 2000 x 35 x 7.5 mm
9290682	Cable duct 2000 x 25 x 60 mm, slotted
9290683	Cable duct 2000 x 40 x 60 mm, slotted
9290968	Coupling relay for DIN rail 6A/250 V AC, with push-in terminals, 1 changeover contact
9290440	Shielding clamp, clamping range 6 - 8 mm
9290684	Potential distribution terminal 12-pole screw-on
9290685	Circuit breaker type C, 2 A, 230 V, 1-pole
9290686	Line circuit breaker 6 A, 1-pole
9290687	Line circuit breaker 10 A, 1-pole
9290979	Coupling relay KA3 including socket
929875	Contactors 240-260 V, 24 A, 4-pole
9290689	Transformer, prim: 230 V – sec: 24 V, 2.5 A, 50-60 Hz
9290091	End bracket for terminal strip ZEW 35
9290690	End plate for terminal strips
929414	Feed-through terminal strip 800 V, 24 A, 2.5 mm ²
9290691	Terminal strip cross connector 24 A
929726	Feed-through terminal strip 6 mm ² , 800 V, 41 A
929727	Feed-through terminal strip 6 mm ² , 800 V, 41 A
9290692	Terminal strip cross connector 24 A
9290693	End plate for terminal strips
991376	Overheating controller, EVD evo Twin driver, including software
929783	Connector kit for EVD controller
930232	Cable temperature sensor OTE 4.0 m, NTC 5K, -40°C to 130°C, IP 68
930315	Contact temperature sensor OTE ANTF3MS/NTC5k/2.0/S
9120441	Cable for coil E2VCABS300
9290694	2-conductor terminal 18 A, 0.08 - 1.5 mm ²
9290695	Feed-through terminal strip 400 V, 18 A, 1.5 mm ²
9290696	End plate with snap-in mount for terminal strips
930226	Contact temperature sensor NTC 10K 800-070
918185	PVC connecting cable for flow sensors with connector M12 x 1, 3 m
917399	Control panel insulation
9290139	Extra package eBus cable M2/M4 OTE MB64xx W22, L 750 mm
918191	Auxiliary PCB OTE, 24 VDC supply for flow sensors

Part number	Detailed designation
919083	Name plate
918135	Dongle GMLW plus
930451	Starting current limiter 15 kW, 32 A
930452	RSBT alarm relay output module
9290148	Cable compressor supply 4 x 4 mm ²
9290149	Compressor protective equipment cable 3 x 1 mm ²
918334	User interface, master remote control
916436	User interface, rear panel
916540	Plexiglass strip M2/M4 red
930312	Controller sensor set
918512	Software OTE 3 DACH
918513	Software OTE 3 EXPORT
917275	Sealing tape PVC/SK self-adhesive, thickness 8 mm, width 12 mm
9290188	Suppressor diode BZW04- 5V8B
9290189	Earth cable M2/M4
923327	Metal clip M4, 0.5 - 4 mm metal thickness
912931	Sealing cap for fill valve, 7/16" UNF
9290245	High limit safety cut-out including cable harness

ACCESSORIES

18. Connection line

Part number	Detailed designation
290755	Connection line set 5 m + cable harness 10 m
290756	Connection line set 10 m + cable harness 15 m
290757	Connection line set 15 m + cable harness 20 m
290758	Connection line set 20 m + cable harness 25 m

19. Controller sensor set

Part number	Detailed designation
930312	Controller sensor set
3 x 930232	Cable temperature sensor OTE, 4 metres, silicone, NTC 5 K
1 x 930313	Outdoor temperature sensor OTE, NTC 5 K
1 x 930314	Contact sensor NTC 5K heating OTE + tension band and heat conducting paste

20. Evaporator sensor set

Part number	Detailed designation
991298	EMC sensor kit including diodes

21. OTE sensors

Part number	Designation
930228	Pressure switch cartridge 25 - 30 bar, ACB-2UB220W
930306	Pressure sensor HP+LP 0.0-34.5 bar
930305	Pressure transmitter S3 – 25 bar

22. Surcharge, heating/cooling

Part number	Detailed designation
800752	Surcharge for heating/cooling, building management system, additional heating circuits when using an auxiliary module

23. OTE Modbus interface (optional)

Part number	Detailed designation
980253	Option – ZIF 180 Modbus interface
918427	ZIF 180 Modbus slave interface
9290139	Extra package eBus cable M2/M4

24. Electricity meter retrofit

Part number	Detailed designation
9291381	Assembly, electricity meter retrofit kit
9290176	Electricity meter 64 A
918215	Auxiliary PCB
9290205	Connection terminals Wago 222 413, 3-pole
9291382	Cable assembly 3 x 6 mm ² , 2 x 1 mm ² , 1 x 0.5 mm ²
9291405	Cable holder

25. Accessories (optional)

Part number	Designation
980190	Electric immersion heater 8.8 kW, internal Note: optional up to Q4/2022
980191	3-way switching module, internal Note: optional up to Q4/2022
922508	Electric immersion heater 6 kW, external
922509	Electric immersion heater 9 kW, external
290341	3-way switching module, DN 40, external

26. Accessories for outdoor unit (optional)

Part number	Designation
915763	Snow cover set 2017 RAL 7016
915795	Snow cover set 2017 RAL 9016
980248	Cylindrical silencer RAL 7016
980250	Cylindrical silencer RAL 9016
915732	Snow cover set SSP RAL 7016
915750	Snow cover set SSP RAL 9016

27. OTE controller accessories

Part number	Designation
918357	Remote controller, white, with graphic display and humidity sensor FB 6104 RH 2.0
918470	Remote controller with touchscreen and integral web2com server
930303	Room temperature and humidity sensor FT 6224
918272	Auxiliary module OTE 3.0
930165	Sensor set for auxiliary module
290503	Switching relay, buffer tank cross-connection

28. Log book

Part number	Designation
982029	Accessories, heat pump service book

TECHNICAL SPECIFICATIONS

CHANGE OVERVIEW FOR LATEST VERSION

29. Medium specification

Part number	Detailed designation
926015	Refrigerant R407c, 3-phase mixture, composition: R134 a > 52% R 125 > 25% R 32 > 23%
	Global warming potential (GWP): 1774
	Refrigerant safety group A1

Section	Change
Liquid line 1	9120698 changed to 912765 9120440 changed to 9120775

30. Compressor specification

Part number	Detailed designation
910125	Compressor ZH24 KVE-TWD-526
	Net weight 93.0 kg
	Length/width/height 368 x 321 x 525 mm
	Supply voltage 400 V / 3 Ph / 50 Hz
	Maximum operating current 18 A
	Blocked rotor current 99 A
	Winding resistance 1.41 ohm
	Swept volume 20.9 m ³ /h
	Sound power 73 dB(A)
	Compressor dimensions L/W/H - 368/321/525 mm
926043	Oil type: POE RL32-3MFA (1-litre container)
	Oil volume 4.0 l
	Additional oil fill volume ex works = 1.0 litres

System installer:	
Company	
Address	
Tel. no.	
Service engineer:	

OCHSNER
Wärmepumpen GmbH Austria
(Commercial register)
Bockgasse 2a
4021 Linz
Austria
kontakt@ochsner.at
www.ochsner.com

OCHSNER
Wärmepumpen GmbH Deutschland
D-10719 Berlin
Kurfürstendamm 11
Hotline for system partners: +49 (0) 1805 832840
Customer service hotline: +49 (0) 69 256694-495
kontakt@ochsner.de
www.ochsner.com

OCHSNER
Wärmepumpen GmbH Switzerland
Uraniastrasse 18
8001 Zurich
Switzerland
Customer service hotline: +41 800 100 911
kontakt@ochsner.com
www.ochsner.com

Head Office/Factory
Ochsner-Strasse 1
3350 Haag
Austria
Hotline for system partners: +43 (0) 820 201020
Customer service hotline: +43 (0) 5 04245-499
kontakt@ochsner.at
www.ochsner.com

OCHSNER East
PL 31-302 Kraków
ul. Pod Fortem Nr. 19
Tel.: +48 12 4214527
kontakt@ochsner.pl
www.ochsner.com

Subject to technical modifications.