

# EXPLODED DIAGRAM

- ▶ AIR 11 C11A
- ▶ AIR 11 C11B

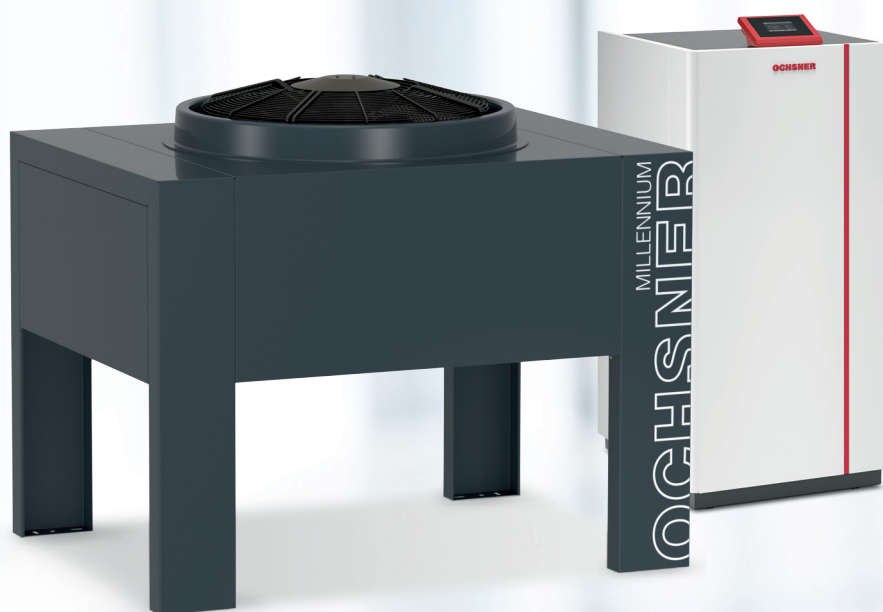

TRANSLATION OF THE ORIGINAL MANUAL

**OCHSNER**  
WÄRMEPUMPEN

## CONTENTS

---

### INDOOR UNIT

1.	Appliance casing	3
2.	User interface	5
3.	Casing frame	6
4.	Refrigerant circuit overview	8
5.	Suction gas line 1	10
6.	Suction gas line 2 + 3 + 4	11
7.	Pressure line 1	12
8.	OVI circuit assembly	13
9.	Liquid line 1	15
10.	Liquid line 2	16
11.	Mounting rail	17
12.	Expansion vessel	18
13.	WNA flow and return	19
13.1	MFA module detail components	20

### OUTDOOR UNIT

14.	VHS-M 9 appliance casing	21
14.1	Special colours for the outdoor unit	21
15.	Overview of components	22
16.	Expansion valve assembly	23

### ELECTRICS

17.	Electrics AIR 11 C11A	24
18.	Electrics AIR 11 C11B	24

### ACCESSORIES

19.	Connection line	25
20.	Controller sensor set	25
21.	Evaporator sensor set	25
22.	OTE sensors	25
23.	Surcharge, heating/cooling	25
24.	OTE Modbus interface (optional)	25
25.	Electricity meter retrofit	25
26.	Accessories (optional)	25
27.	Accessories for outdoor unit (optional)	25
28.	OTE controller accessories	25
29.	Log book	25

### TECHNICAL SPECIFICATIONS

30.	Medium specification	26
31.	Compressor specification AIR 11 C11A	26
32.	Compressor specification AIR 11 C11B	26

# INDOOR UNIT

## 1. Appliance casing

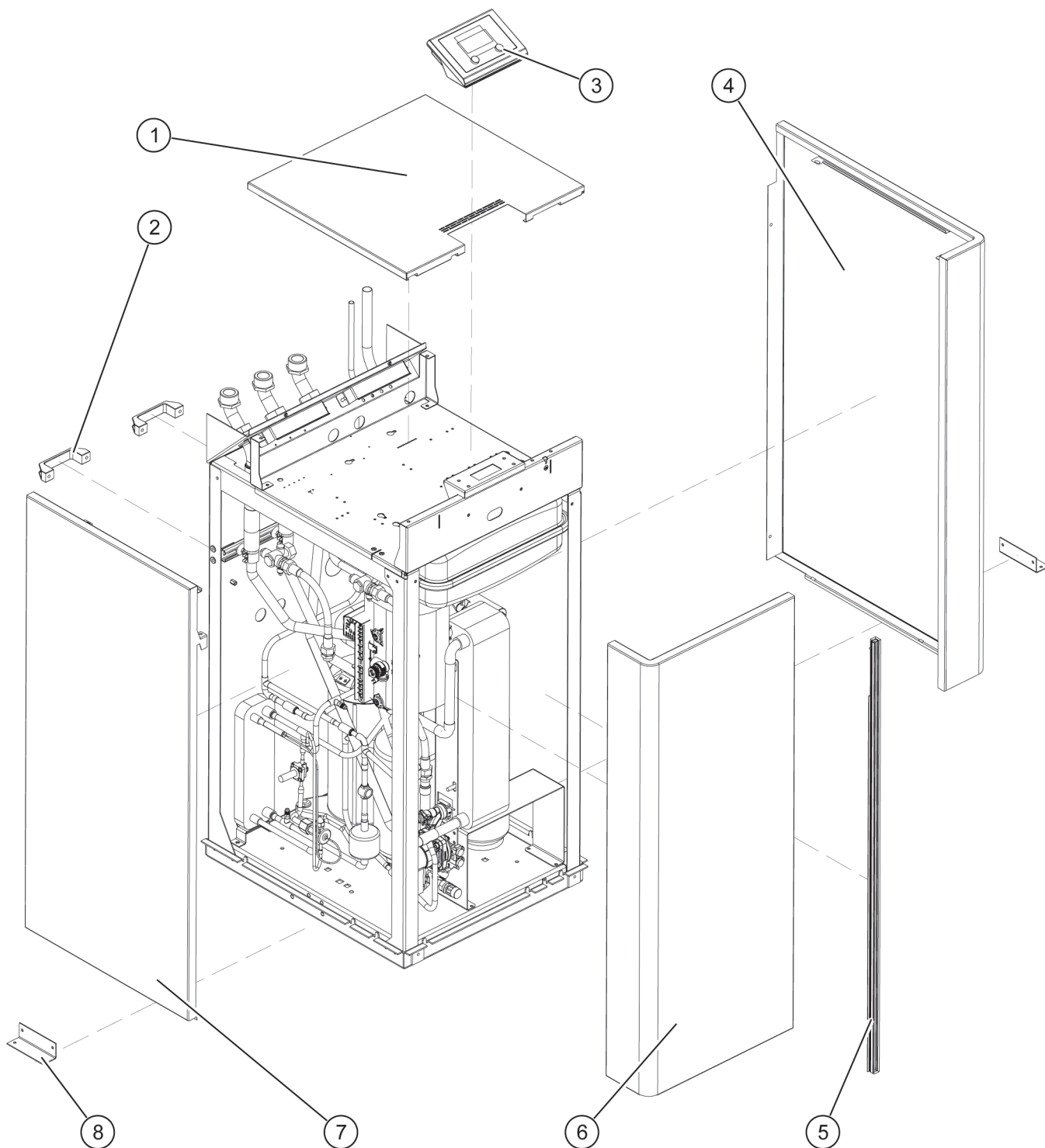

OCH\_08\_09\_200\_202\_001\_004

Key	Part number	Designation
1	915641	Top cover M2/M4 RAL 7016
2	916471	Strap grip
2.1	923343	Hexagon socket screw M6 x 25 mm

Key	Part number	Designation
3	x	Maxi terminal (see page 5, User interface)
4	991289	Side section right M2/M4 RAL 9016

## EXPLODED DIAGRAM | Appliance casing

---

Key	Part number	Designation
5	916540	Plexiglass strip M2/M4 red
6	991287	Front panel M2/M4 RAL 9016
7	991288	Side section left M2/M4 RAL 9016
8	915698	Transport bracket

## 2. User interface

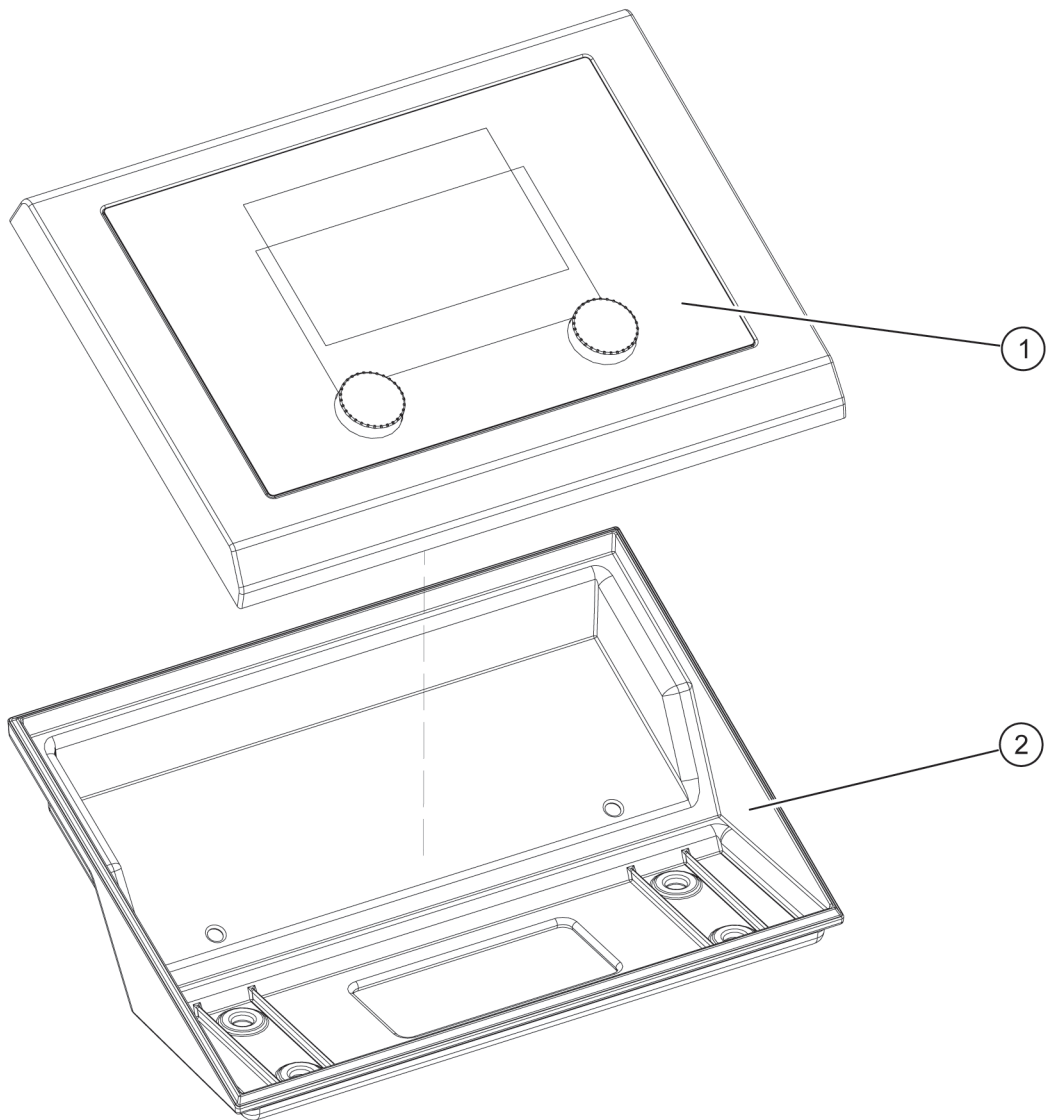

Key	Part number	Designation
1	918334	User interface, master remote control
2	916436	User interface, rear panel
2.1	923287	Round head screw M6 x 16 mm

### 3. Casing frame

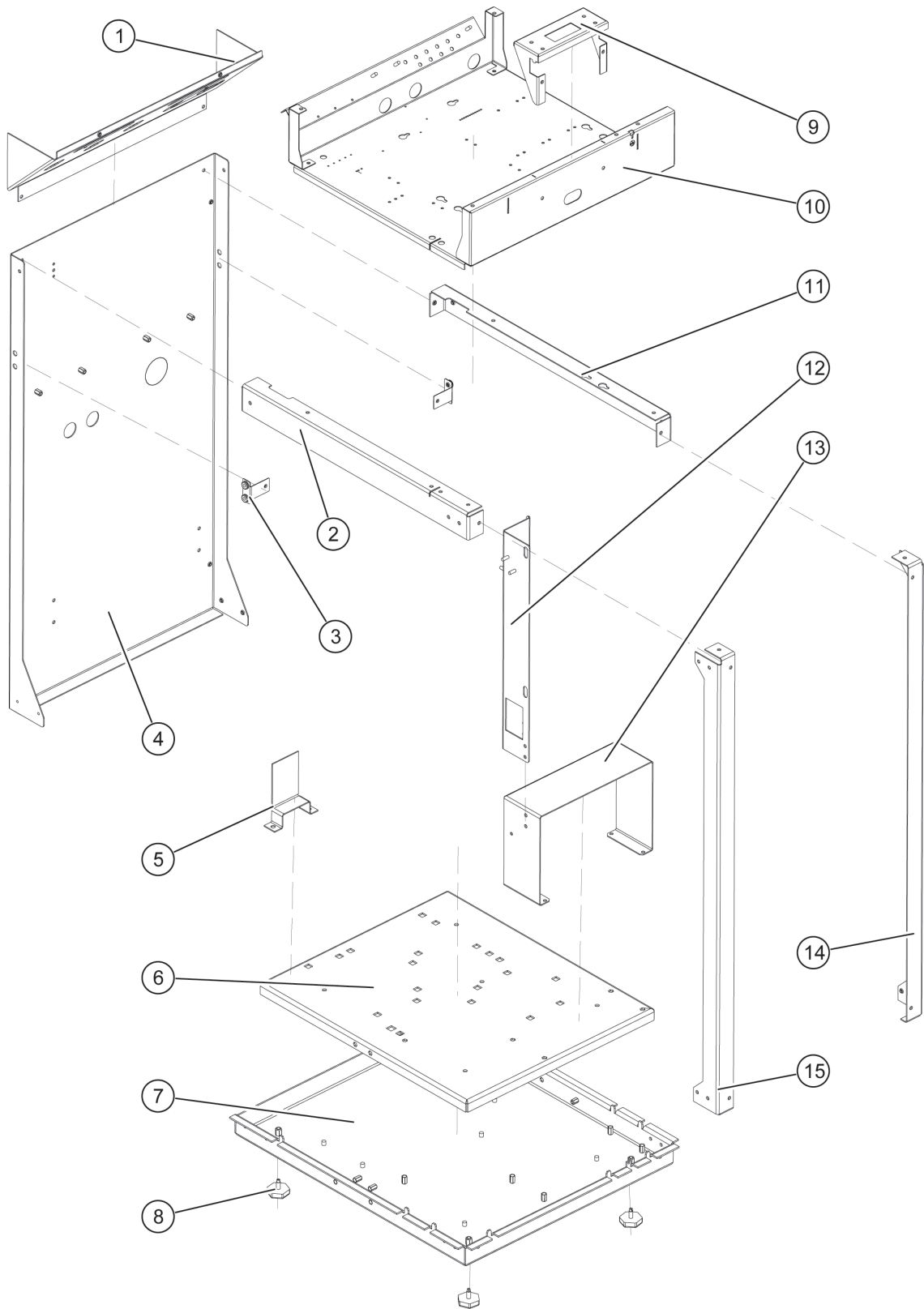

OCH\_08\_09\_200\_202\_001\_016

Key	Part number	Designation
1	915755	Back panel, hydraulic connection plate
2	915743	Maxi base frame strut, top left
3	915966	Mounting rail bracket M2/M4

Key	Part number	Designation
4	915939	Back panel M2/M4
5	915749	ECO bracket M2/M4
6	915883	Maxi mounting plate base

## EXPLODED DIAGRAM | Casing frame

---

Key	Part number	Designation
7	915878	Maxi base plate
8	916458	Universal slider
9	915713	Maxi touchscreen bracket
10	915637	Maxi control box base plate (see page 24, Electrics AIR 11 C11A)
11	915742	Base frame strut, top right
12	915708	Maxi bracket condenser 2
13	915707	Maxi bracket condenser 1
14	915742	Base frame strut, front right
15	915741	Base frame strut, front left
	923373	Fixing strap set (transport aid)

## 4. Refrigerant circuit overview

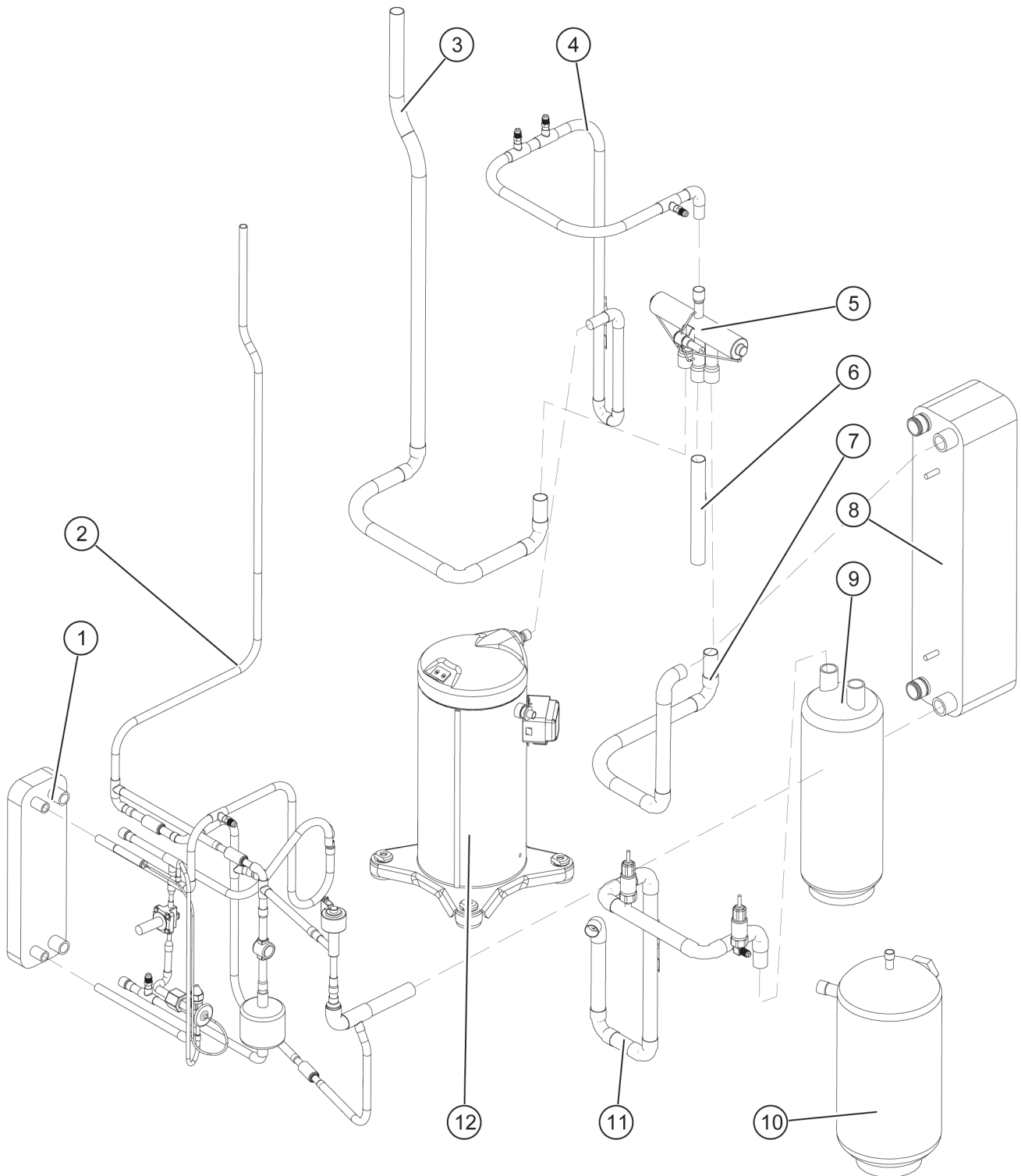

OCH\_08\_09\_200\_202\_001\_007

Key	Part number	Designation
1	911315	Plate heat exchanger AC30EQ-14H-G
2	x	Liquid line (see page 13, OVI circuit assembly)
	x	Liquid line (see page 15, Liquid line 1)
	x	Liquid line (see page 16, Liquid line 2)

Key	Part number	Designation
3	x	Suction gas line 3 (see page 11, Suction gas line 2 + 3 + 4)
4	x	Pressure line 1 (see page 12, Pressure line 1)
5	912290	Solenoid valve 4-way STF-0413G3
5.1	912514	Solenoid valve coil 4-way valve

## EXPLODED DIAGRAM | Refrigerant circuit overview

---

Key	Part number	Designation
6	x	Suction gas line 2 (see page 11, Suction gas line 2 + 3 + 4)
7	x	Suction gas line 4 (see page 11, Suction gas line 2 + 3 + 4)
8	911529	Plate heat exchanger CB62-50AH-G
8.1	991282	Assembly, plate heat exchanger condenser including insulation
9	912597	Fluid separator ESK FA-22/10-OCH
9.1	917449	Insulation for fluid separator
10	912599	Liquid receiver 5.6 l with sight glass
11	x	Suction gas line 1 (see page 10, Suction gas line 1)
12	910150	Compressor ZH09 KVE-TFD-526 for AIR 11 C11A
	910165	Compressor ZH09KVE-PFZ-526 for AIR 11 C11B
12.1	910103	Compressor motor protection INT 69 SC2

## 5. Suction gas line 1

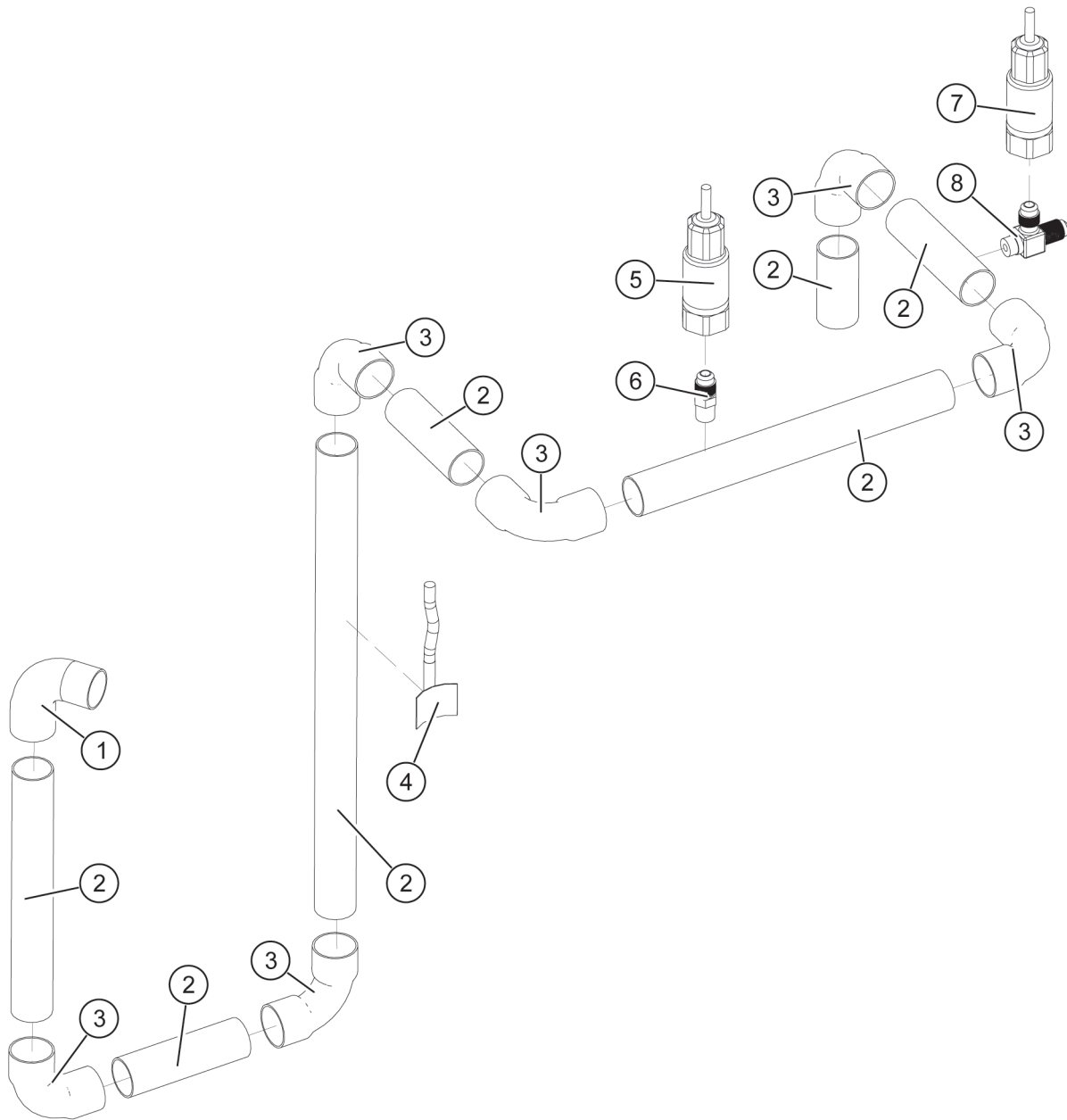

Key	Part number	Designation
1	913035	Copper bend 90° 22 mm f/m 5001A
2	x	Copper pipe 22 x 1 mm
3	913019	Copper bend 90°, 22 mm, f/f, 5002A
4	930315	Contact temperature sensor OTE NTC 5K
5	930305	Pressure transmitter S3, 25 bar
5.1	918469	Cable quick release fitting
5.2	912449	Copper sealing ring 6 mm 1/4"
6	912638	Fill valve single
6.1	912589	Insert for fill valve, blue seal ring
7	930306	Pressure sensor HP+LP 0.0-34.5 bar
7.1	918469	Cable quick release fitting
7.2	912449	Copper sealing ring 6 mm 1/4"

Key	Part number	Designation
8	912639	Fill valve double
8.1	912589	Insert for fill valve, blue seal ring

## 6. Suction gas line 2 + 3 + 4

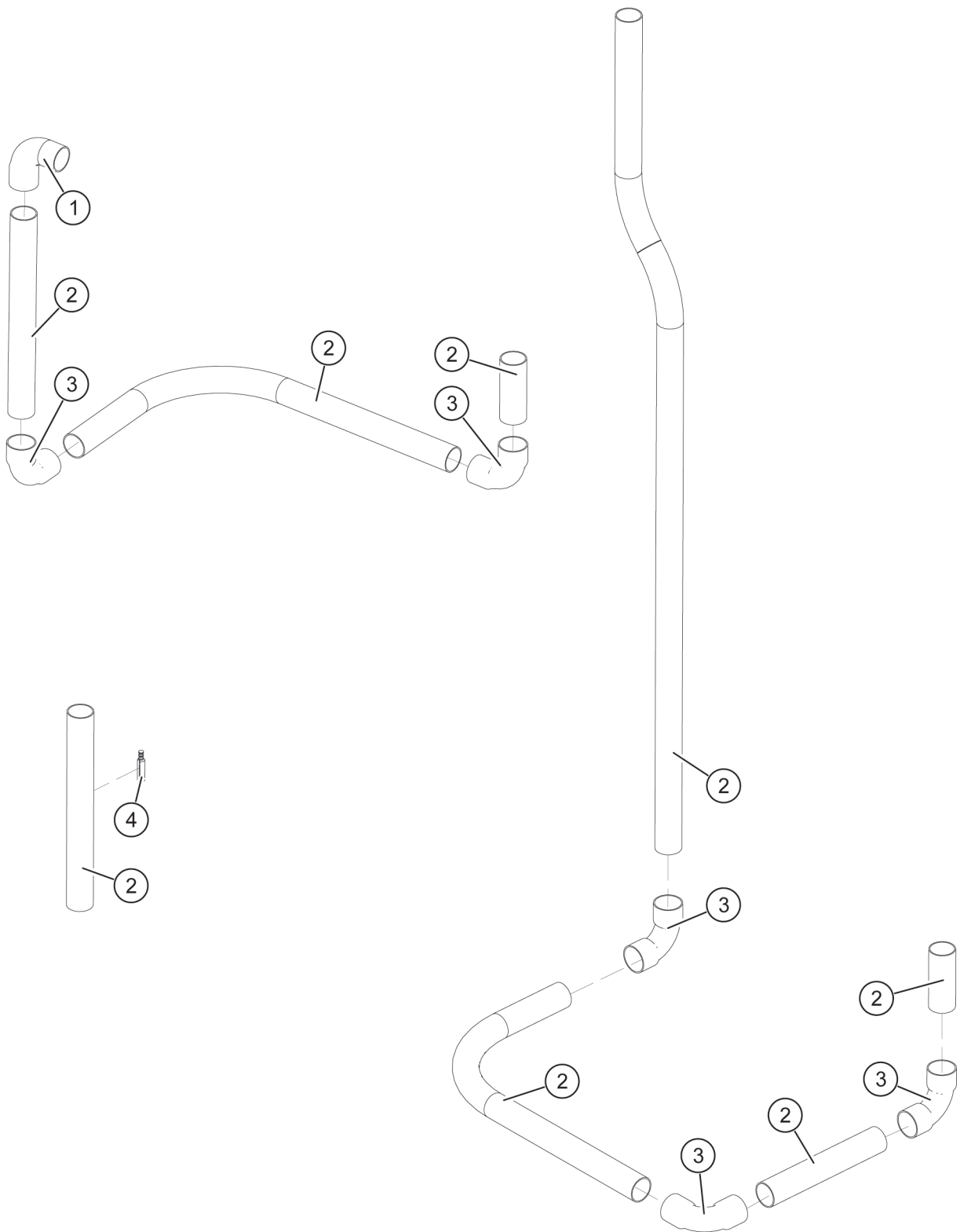

Key	Part number	Designation
1	913035	Copper bend 90° 22 mm f/m 5001A
2	x	Copper pipe 22 x 1 mm
3	913019	Copper bend 90°, 22 mm, f/f, 5002A
4	930226	Contact temperature sensor NTC 10K 800-070

## 7. Pressure line 1

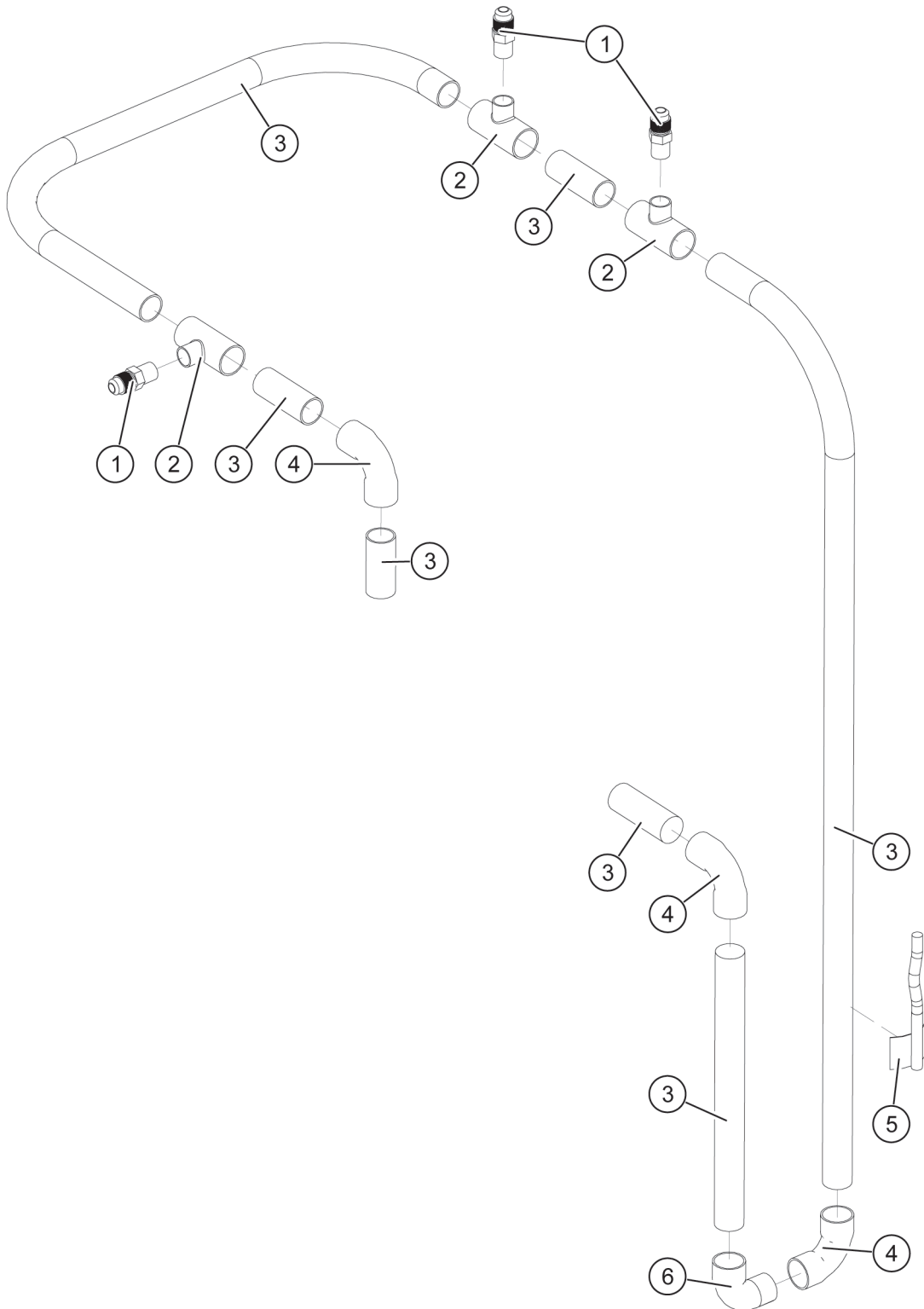

OCH\_08\_09\_200\_202\_001\_010

Key	Part number	Designation
1	912638	Fill valve single
1.1	912589	Insert for fill valve, blue seal ring
2	913208	Tee 16 x 10 x 16 mm, 5130
3	x	Copper pipe 16 x 1 mm
4	913323	Copper bend 90°, 16 mm, f/f, 5002A

Key	Part number	Designation
5	930315	Contact temperature sensor OTE, AF 25, NTC 5k, -35°C to 150°C, 2 m cable silicone
6	913316	Copper bend 90°, 16 mm, f/m, 5001A

## 8. OVI circuit assembly

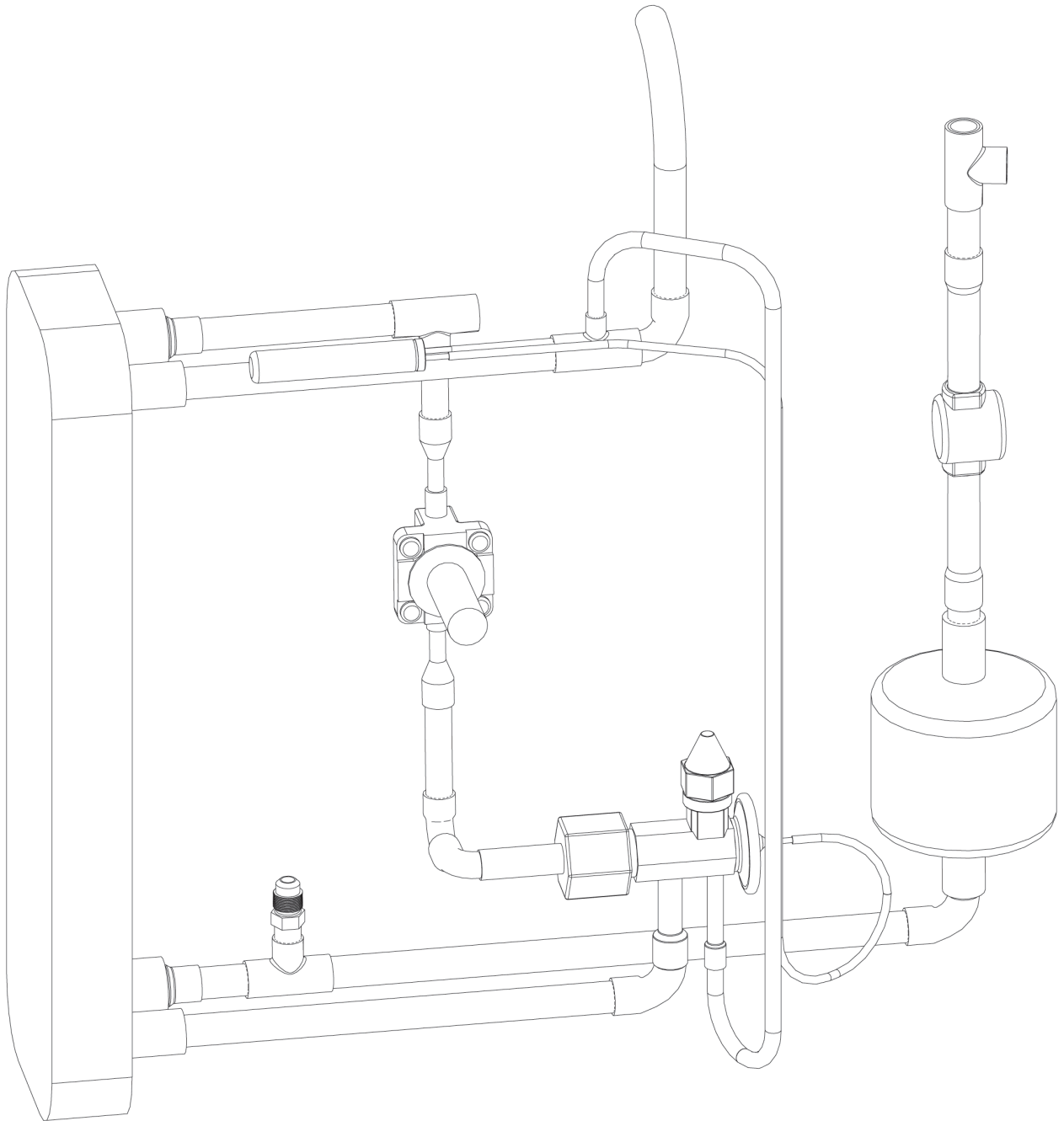

OCH\_08\_09\_200\_202\_001\_011

Part number	Detailed designation
991863	OVI circuit assembly
911315	Plate heat exchanger AC30EQ-14H-G
912773	Solenoid valve without coil, EVR 3, 10 mm soldered
912774	Coil for solenoid valve 12 W, 230 V, 50/60 Hz
912335	Solder adaptor 10 mm
912413	Thermostatic valve for EVI, TMVXBL-E0684 R407C +30/-30°C
9220375	Silicone hose 50 mm, slotted, NW 6 x 2 mm
912462	Nozzle 0.7 mm
912970	Sight glass 12 mm, SYJ12H12
912972	Filter dryer DTG-B03 121-901

Part number	Detailed designation
912638	Fill valve single
913096	Reducing nipple 16 x 12 mm, (m/f), 5243
913017	Copper bend 90°, 12 mm, f/m, 5001A
913016	Copper bend 90°, 10 mm, f/m, 5001A
913040	Tee 12 x 6 x 12 mm
913039	Tee 12 x 12 x 12 mm
913097	Tee 12 x 10 x 12 mm
917014	Insulating sleeve 9 x 12 mm
913047	Copper pipe 12 x 1 mm, R220
913048	Copper pipe 10 x 1 mm, R220
913049	Copper pipe 6 x 1 mm, R220

## EXPLODED DIAGRAM | OVI circuit assembly

---

Part number	Detailed designation
930163	Sensor clip 190 mm
925049	Edge protection corners with tape slots

### 9. Liquid line 1

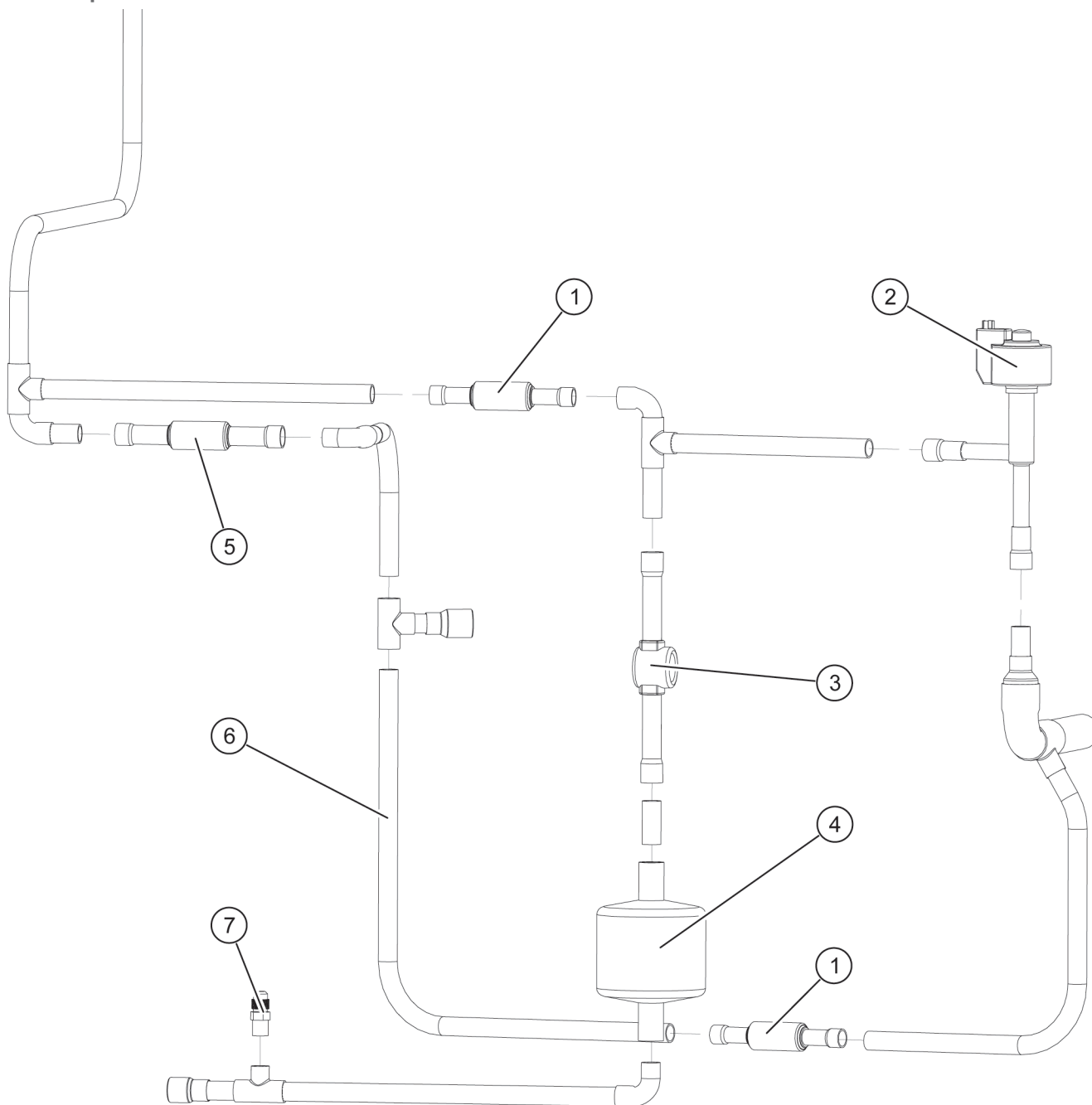

OCH\_08\_09\_200\_202\_001\_012

Key	Part number	Designation
1	912038	Non-return valve NRV6 s 10 mm soldered
2	9120696	Expansion valve E2V24FSFC1 without stepper motor
2.1	9120440	Stepper motor for thermostatic valve electronic
3	912970	Sight glass 12 mm, SYJ12H12
4	912972	Filter dryer DTG-B03 121-901
5	912261	Non-return valve NRV 10s, 12 mm soldered
6	x	Copper pipe 12 x 1 mm
7	912638	Fill valve single
7.1	912589	Insert for fill valve, blue seal ring

## 10. Liquid line 2

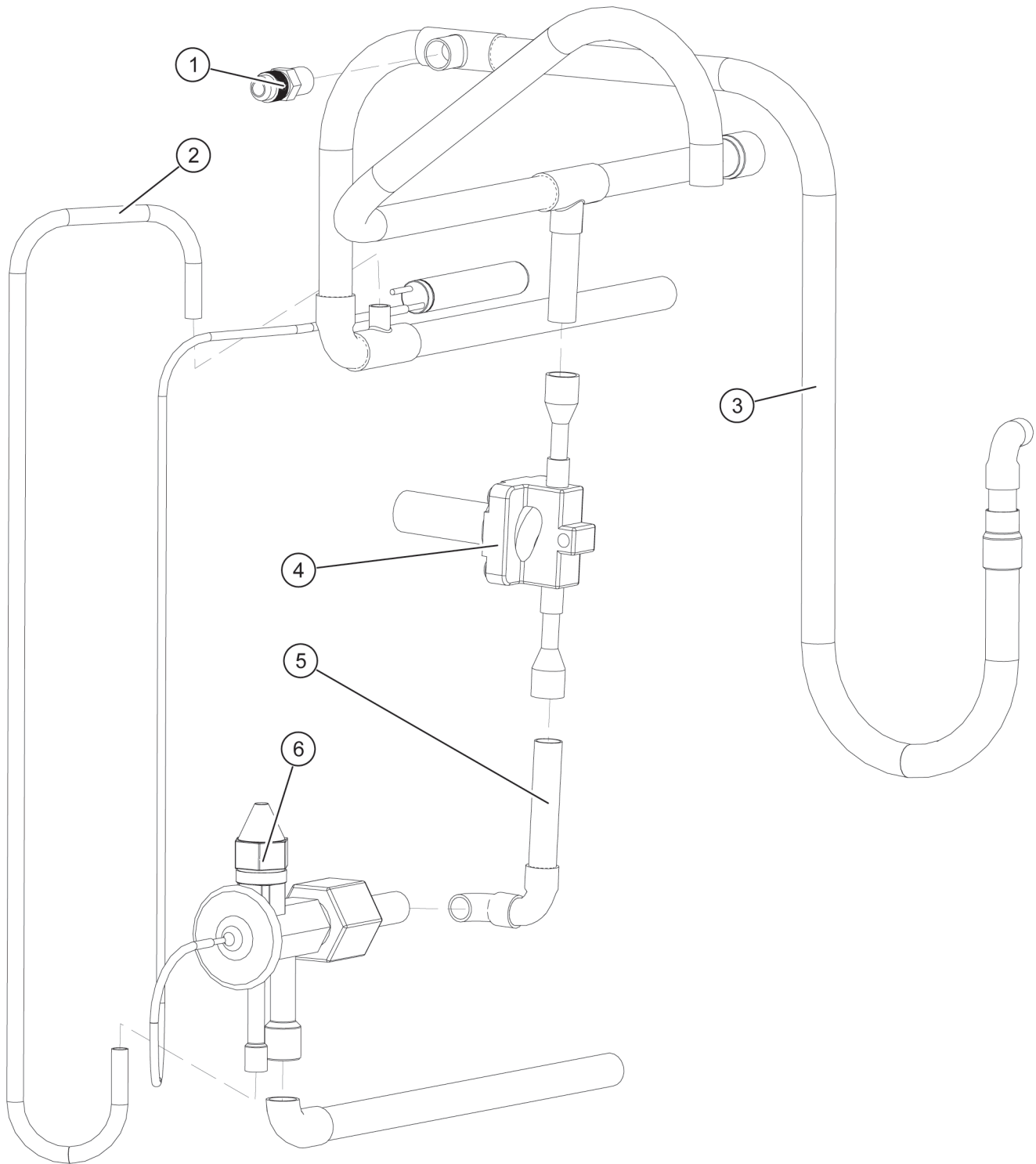

OCH\_08\_09\_200\_202\_001\_013

Key	Part number	Designation
1	912638	Fill valve single
1.1	912589	Insert for fill valve, blue seal ring
2	x	Copper pipe 6 x 1 mm
3	x	Copper pipe 12 x 1 mm
4	912773	Solenoid valve without coil, EVR 3, 10 mm soldered
4.1	912774	Coil for solenoid valve 12 W, 230 V, 50/60 Hz

Key	Part number	Designation
5	x	Copper pipe 10 x 1 mm
6	912413	Thermostatic valve for EVI, TMVX-BL-E0684 R407C +30/-30°C
6.1	912462	Nozzle 0.7 mm

## 11. Mounting rail

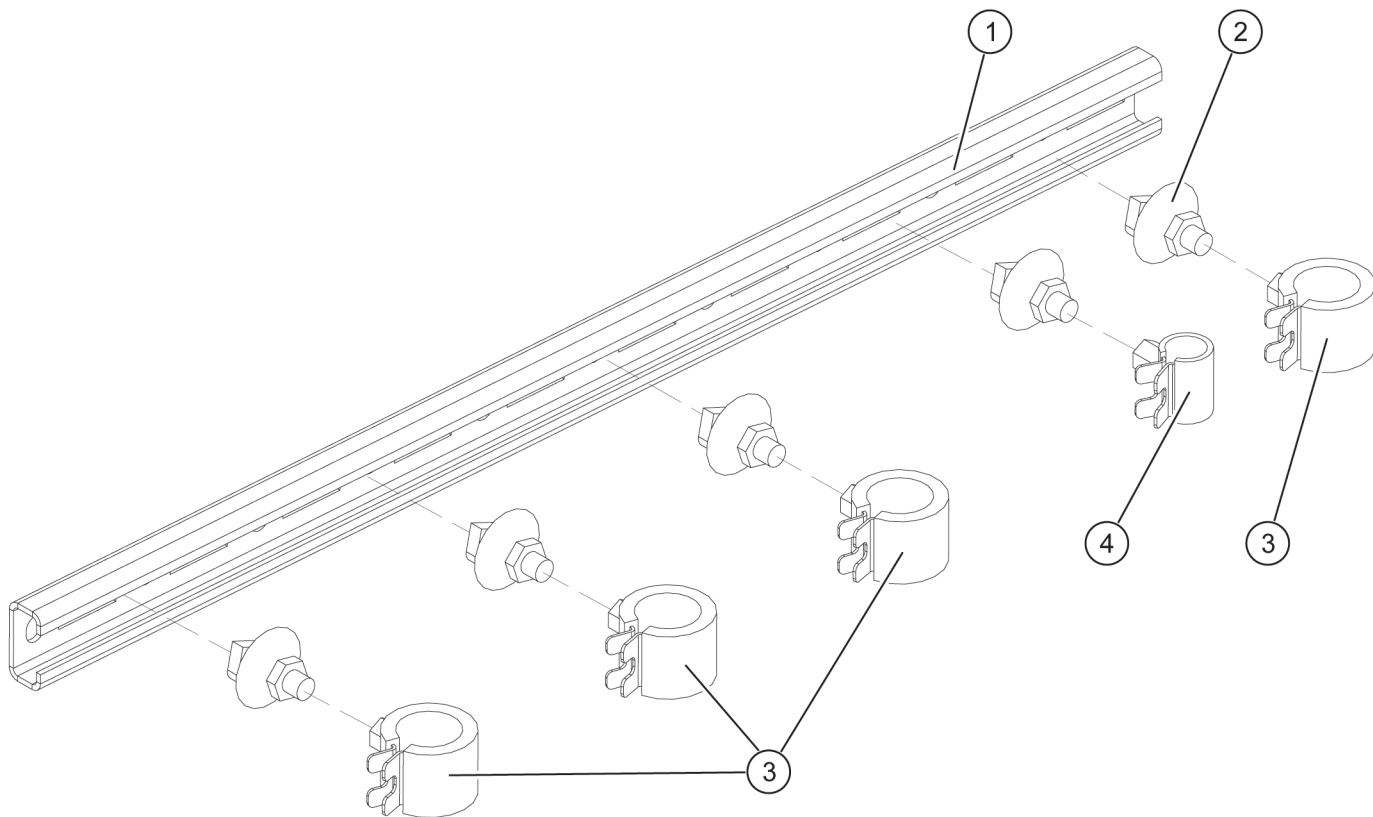

Key	Part number	Designation
	923338	Mounting rail assembly
1	923332	Mounting rail 0.5 m galvanised
2	923333	Fixing screw M8
3	9220069	Pipe clamp 31 - 35 mm M8
4	9220066	Pipe clamp 15 - 18 mm M8

OCH\_08\_09\_200\_202\_001\_014

## 12. Expansion vessel

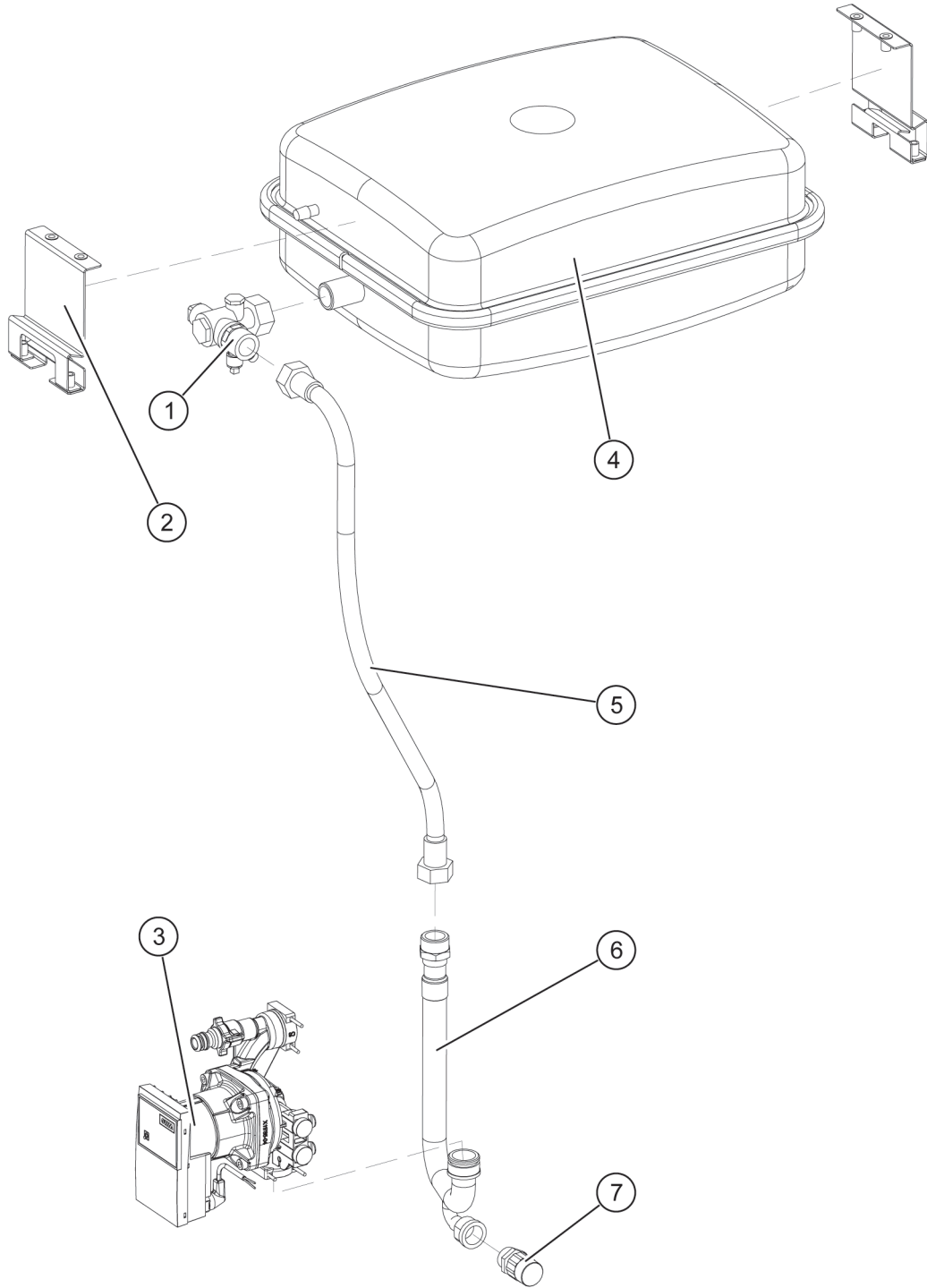

Key	Part number	Designation
1	914382	Angle valve 3/4" for expansion vessel
2	915712	Bracket, expansion vessel
3	922586	Energy saving pump Yonos PARA HPS 25/7.5 RKC-M
4	922638	Expansion vessel 24 litres, 3 bar
5	922723	Flexible hose 3/4" L 700 mm
6	922703	Pipe assembly WNA expansion vessel
7	914347	Fill/drain valve, type 191 G1/2"

### 13. WNA flow and return

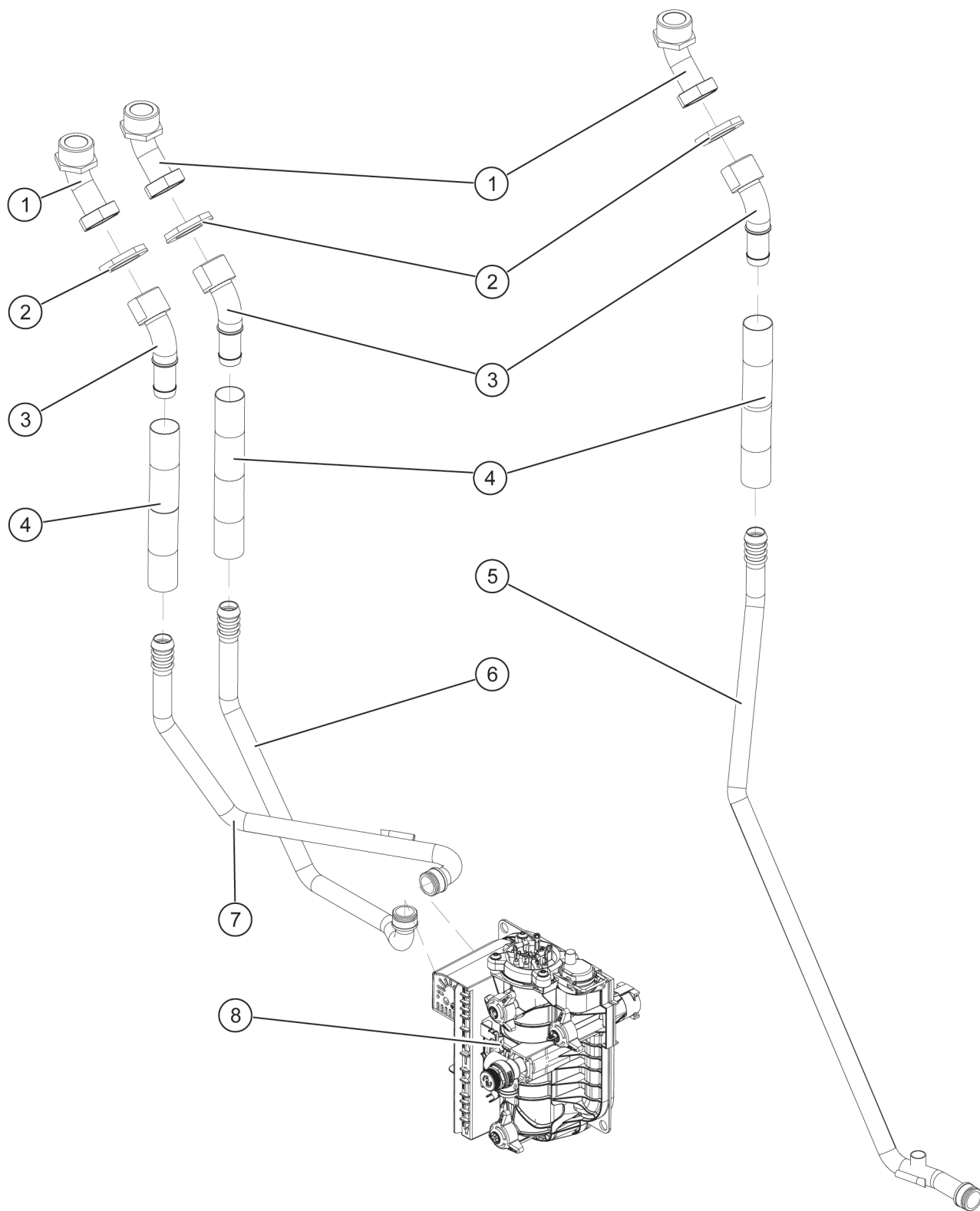

OCH\_08\_09\_200\_202\_001\_016

Key	Part number	Designation
1	922738	Connection pipe external 5/4" M2/M4, with soldered MS threaded connector
2	913535	Hexagon nut 5/4", 5000OT series
3	922716	Connection pipe 5/4" M2/M4, with soldered MS threaded connector

Key	Part number	Designation
4	916477	Pressure hose L 210 mm internal diameter 25 mm
4.1	922735	Hose clip without screw
5	922704	WNA return M2
6	922706	WNA flow 2 M2

## EXPLODED DIAGRAM | WNA flow and return

---

Key	Part number	Designation
7	922705	WNA flow 1 M2
8	922795	Multifunctional assembly MFA1 OEM 2, including e-heater
8.1	922828	Multifunctional assembly MFA1 including caps without auxiliary heater

### 13.1 MFA module detail components

Part number	Detailed designation
922671	Automatic fan for MFA
922670	Safety valve for MFA
918182	Flow sensor Typ211
9220144	3-way switching module MFA for all versions
9290133	Actuation control cable for MFA module
922576	Retaining clip for MFA1
916500	Pipe connection plug for MFA module
922575	O-ring for solder adaptor, 25 x 2.5 mm
9220129	Electric immersion heater (8.8 kW) for MFA module

# OUTDOOR UNIT

## 14. VHS-M 9 appliance casing

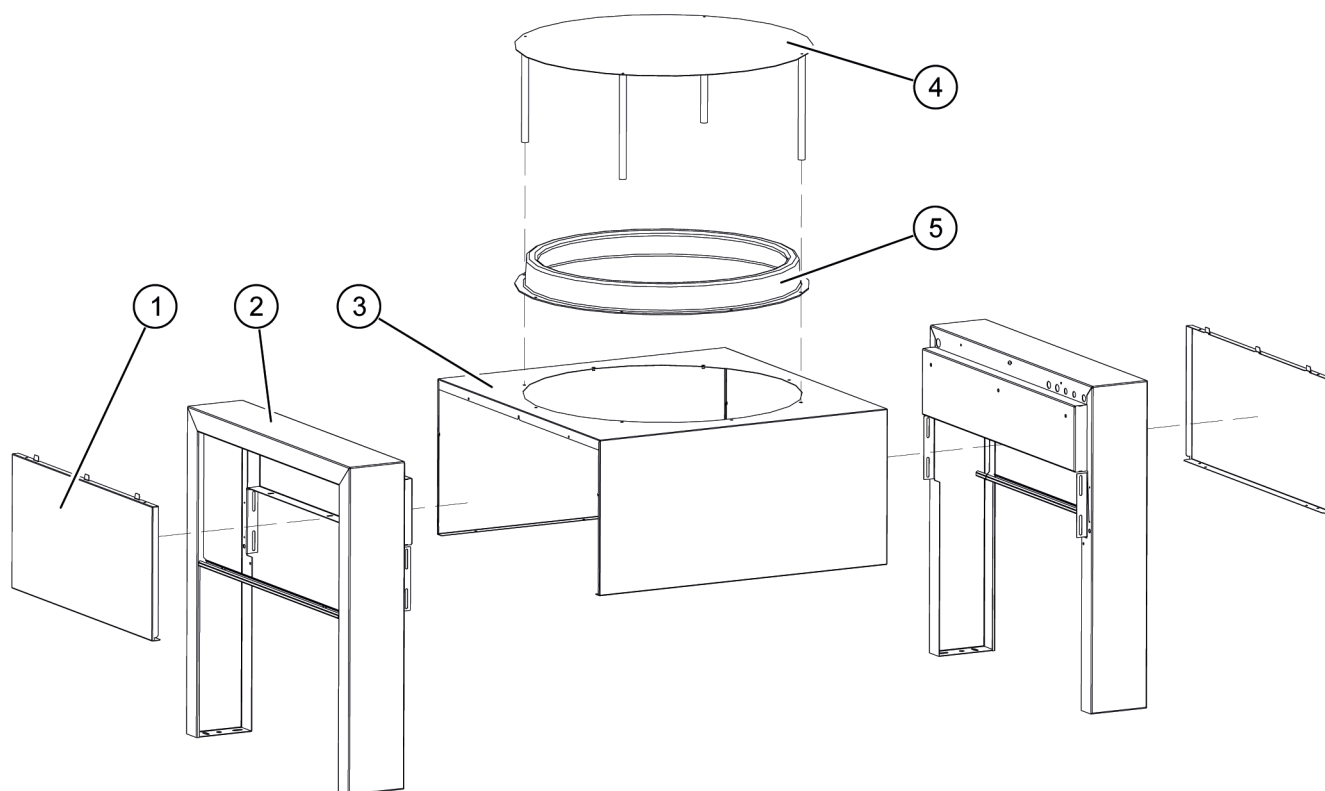

OCH\_08\_09\_200\_202\_001\_001

Key	Part number	Designation
1	915593	Side cover RAL 7016
	915610	Side cover RAL 9016
1.1	916629	Frame buffer 8 mm
2	991024	Base with OCHSNER logo affixed, RAL 7016
	991051	Base with OCHSNER logo affixed, RAL 9016
3	915590	Cowl RAL 7016
	915611	Cowl RAL 9016
4	915763	Snow cover set 2017 RAL 7016
	915795	Snow cover set 2017 RAL 9016
5	932033	Reducer ring complete RAL 7016
	932034	Reducer ring complete RAL 9016

### 14.1 Special colours for the outdoor unit

**i Note** The spare parts numbers in this documentation relate to standard colours RAL 7016 “anthracite grey” and RAL 9016 “traffic white”.

If a special colour was used for the outdoor unit and you require a spare part in this special colour, please email us.

Your email should include the following details:

- ▶ Name
- ▶ Address
- ▶ Serial number of the indoor unit and outdoor unit
- ▶ Spare part required

## 15. Overview of components

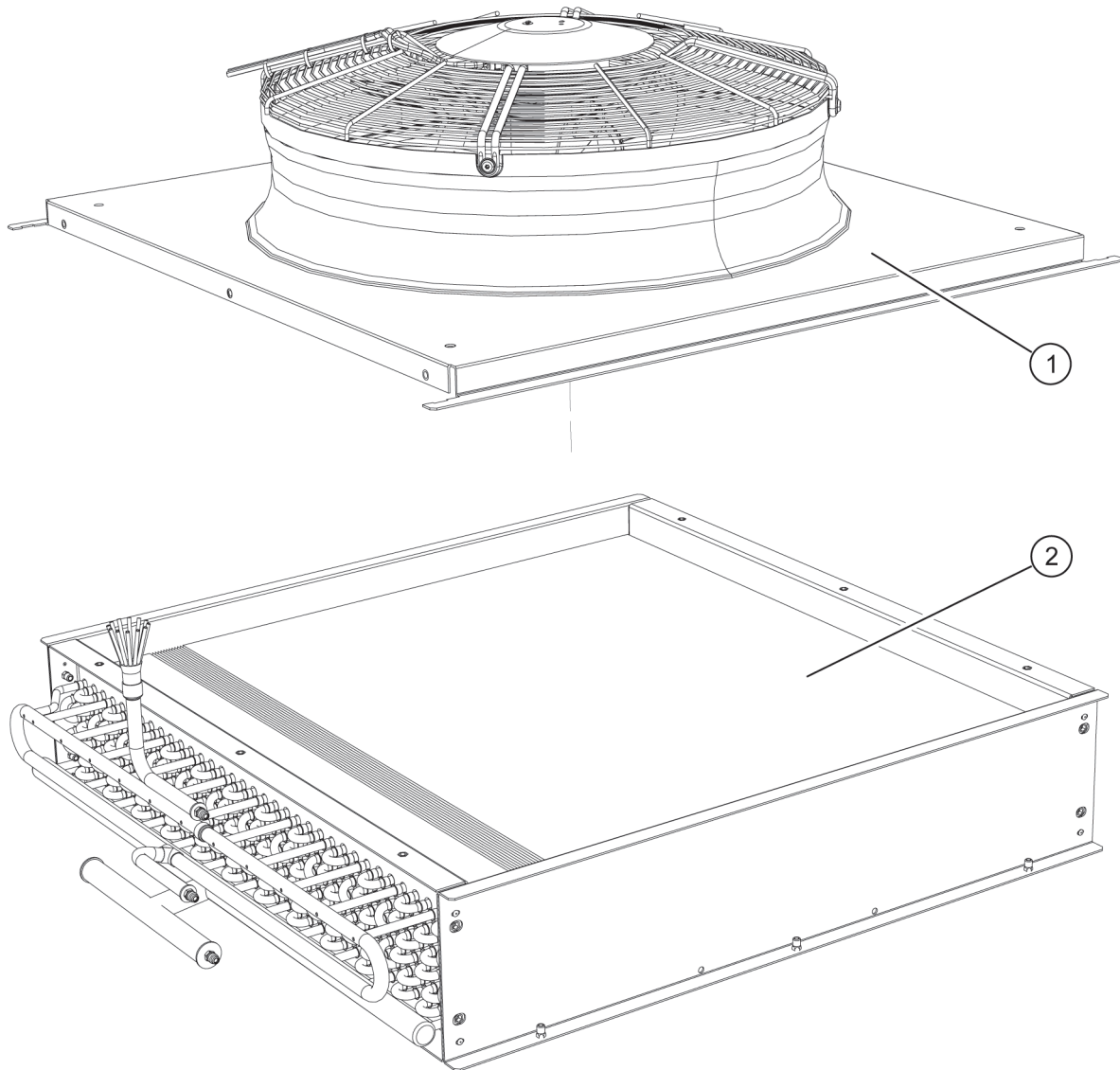

Key	Part number	Designation
1	931076	Fan W3G630-GD05-50-DB – fan being phased out
	931115	Fan W3G630-GL06-G4 – fan new
	931137	Fan WEI.EC102/50E3G01-AS630/82P1-02-B1 - fan alternative
2	912656	Evaporator fins GMLW 5/ 9 – AIR 11

OCH\_08\_09\_200\_202\_001\_002

## 16. Expansion valve assembly

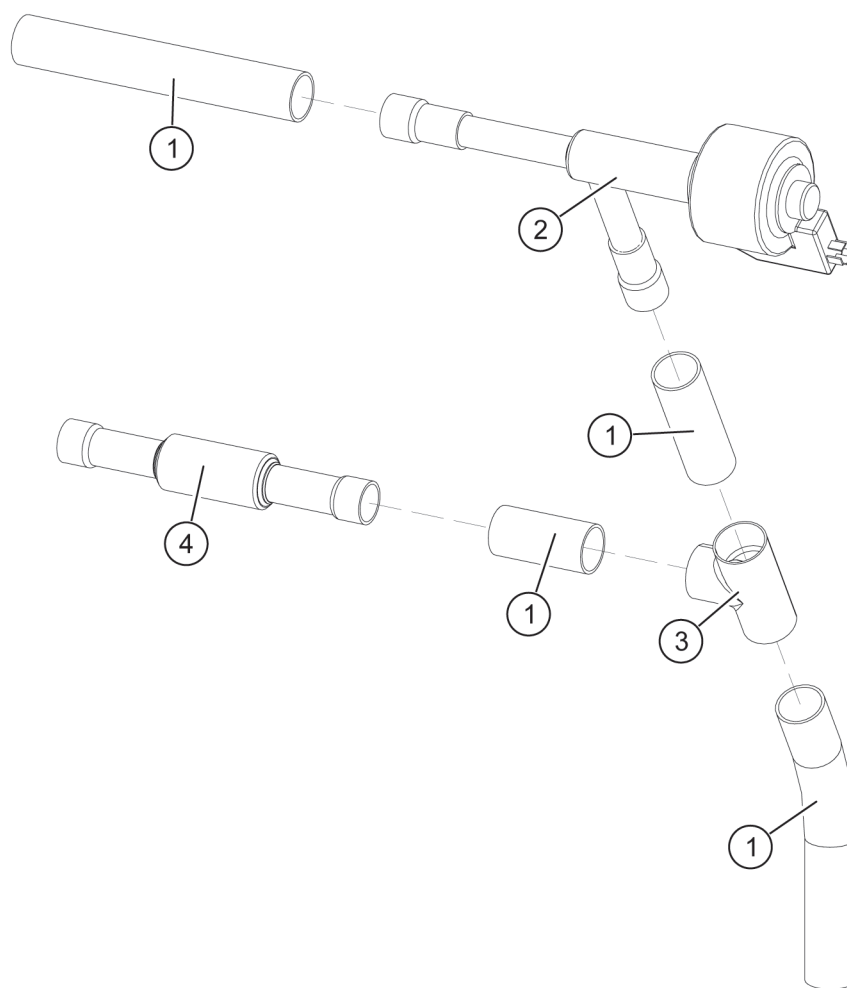

Key	Part number	Designation
	990936	Expansion valve assembly VHS-M 09/14
1	x	Copper pipe 16 x 1 mm
2	9120696	Expansion valve E2V24FSFC1 without stepper motor
2.1	9120440	Stepper motor for thermostatic valve electronic
3	913085	Tee 16 x 16 x 16 mm, 5130
4	912261	Non-return valve, NRV 10s, 12 mm soldered

## ELECTRICS

## 17. Electrics AIR 11 C11A

Part number	Detailed designation
918204	Controller WPC OTE plus 3.0
9290128	Control box AIR M2/M4
915637	Maxi control box base plate
915713	Maxi touchscreen bracket
915714	Cable entry Maxi DC01 EVZ25
917527	Safety guard 160 x 20 x 20 mm
9290698	Cable tie mounting base
922679	Cover clip, clamping range 3 - 23 mm
9290681	Top-hat profile rail with drilled holes TS 2000 x 35 x 7.5 mm
9290682	Cable duct 2000 x 25 x 60 mm, slotted
9290683	Cable duct 2000 x 40 x 60 mm, slotted
9290968	Coupling relay for DIN rail 6A/250 V AC, with push-in terminals, 1 changeover contact
9290440	Shielding clamp, clamping range 6 - 8 mm
9290684	Potential distribution terminal 12-pole screw-on
9290685	Circuit breaker type C, 2 A, 230 V, 1-pole
9290686	Line circuit breaker 6 A, 1-pole
9290687	Line circuit breaker 10 A, 1-pole
9290979	Coupling relay KA3 including socket
929875	Contact 240-260 V, 24 A, 4-pole
9290689	Transformer, prim: 230 V – sec: 24 V, 2.5 A, 50-60 Hz
9290091	End bracket for terminal strip ZEWE 35
9290690	End plate for terminal strips
929414	Feed-through terminal strip 800 V, 24 A, 2.5 mm <sup>2</sup>
9290691	Terminal strip cross connector 24 A
929726	Feed-through terminal strip 6 mm <sup>2</sup> , 800 V, 41 A
929727	Feed-through terminal strip 6 mm <sup>2</sup> , 800 V, 41 A
9290692	Terminal strip cross connector 24 A
9290693	End plate for terminal strips
991376	Overheating controller, EVD evo Twin driver, including software
929783	Connector kit for EVD controller
930232	Cable temperature sensor OTE 4.0 m, NTC 5K, -40°C to 130°C, IP 68
930315	Contact temperature sensor OTE ANTF3MS/NTC5k/2.0/S
9120441	Cable for coil E2VCABS300
9290694	2-conductor terminal 18 A, 0.08 - 1.5 mm <sup>2</sup>
9290695	Feed-through terminal strip 400 V, 18 A, 1.5 mm <sup>2</sup>
9290696	End plate with snap-in mount for terminal strips
930226	Contact temperature sensor NTC 10K 800-070
918185	PVC connecting cable for flow sensors with connector M12 x 1, 3 m
917399	Control panel insulation
9290139	Extra package eBus cable M2/M4 OTE MB64xx W22, L 750 mm
918191	Auxiliary PCB OTE, 24 VDC supply for flow sensors
919083	Name plate

Part number	Detailed designation
918135	Dongle GMLW plus
930449	Starting current limiter CG, 7.5 kW, 16 A
930452	RSBT alarm relay output module
9290146	Cable compressor supply 4 x 2.5 mm <sup>2</sup>
918334	User interface, master remote control
916436	User interface, rear panel
916540	Plexiglass strip M2/M4 red
930312	Controller sensor set
918512	Software OTE 3 DACH
918513	Software OTE 3 EXPORT
917275	Sealing tape PVC/SK self-adhesive, thickness 8 mm, width 12 mm
9290189	Earth cable M2/M4
923327	Metal clip M4, 0.5 - 4 mm metal thickness
9290245	Extra package, high limit safety cut-out including cable assembly
929909	Interference filter FN 2020

## 18. Electrics AIR 11 C11B

Part number	Detailed designation
923327	Metal clip M4, 0.5 - 4 mm metal thickness
922798	Corrugated pipe NW12, 230 mm
922799	Corrugated pipe NW17, 350 mm
918204	Controller WPC OTE plus 3.0, SE 6024 WPC OCH, HW 3.0
9290131	Control box AIR VX M2 M4
9290139	Extra package eBus cable M2/M4 OTE MB64xx W22, L 750 mm
918191	Auxiliary PCB OTE, 24 VDC supply, for flow sensors
919083	Name plate
918135	Dongle GMLW plus with shrink-on tube
918334	User interface, master remote control
916436	User interface, rear panel
916540	Plexiglass strip M2/M4 red
930312	Controller sensor set
918512	Software OTE3 DACH
918513	Software OTE3 EXPORT
917275	Sealing tape PVC/SK self-adhesive, thickness 8 mm, width 12 mm
9290188	Suppressor diode BZW04- 5V8B
9290189	Earth cable M2M4
910101	Operating capacitor for ZR48 and ZH13, 230 V
912931	Sealing cap for fill valve, 7/16" UNF
9290411	Contact 18.5 kW - AF38-30-00- 13, 100 - 250 V, 50/60 HZ-DC, ABB

## ACCESSORIES

### 19. Connection line

Part number	Detailed designation
290743	Connection line set 5 m + cable harness 10 m
290744	Connection line set 10 m + cable harness 15 m
290745	Connection line set 15 m + cable harness 20 m
290746	Connection line set 20 m + cable harness 25 m

### 20. Controller sensor set

Part number	Detailed designation
930312	Controller sensor set
3 x 930232	Cable temperature sensor OTE, 4 metres, silicone, NTC 5 K
1 x 930313	Outdoor temperature sensor OTE, NTC 5 K
1 x 930314	Contact sensor NTC 5K heating OTE + tension band and heat conducting paste

### 21. Evaporator sensor set

Part number	Detailed designation
991298	EMC sensor kit including diodes

### 22. OTE sensors

Part number	Designation
930228	Pressure switch cartridge 25 - 30 bar, ACB-2UB220W
930306	Pressure sensor HP+LP 0.0-34.5 bar
930305	Pressure transmitter S3 – 25 bar

### 23. Surcharge, heating/cooling

Part number	Detailed designation
800752	Surcharge for heating/cooling, building management system, additional heating circuits when using an auxiliary module

### 24. OTE Modbus interface (optional)

Part number	Detailed designation
980253	Option – ZIF 180 Modbus interface
918427	ZIF 180 Modbus slave interface
9290139	Extra package eBus cable M2/M4

### 25. Electricity meter retrofit

Part number	Detailed designation
9291381	Assembly, electricity meter retrofit kit
9290176	Electricity meter 64 A
918215	Auxiliary PCB
9290205	Connection terminals Wago 222 413, 3-pole
9291382	Cable assembly 3 x 6 mm <sup>2</sup> , 2 x 1 mm <sup>2</sup> , 1 x 0.5 mm <sup>2</sup>
9291405	Cable holder

### 26. Accessories (optional)

Part number	Designation
980197	Electric immersion heater 8.8 kW, internal
980198	3-way switching module, internal
922508	Electric immersion heater 6 kW, external
922509	Electric immersion heater 9 kW, external
290229	3-way switching module, DN 32, external

### 27. Accessories for outdoor unit (optional)

Part number	Designation
915763	Snow cover set 2017 RAL 7016
915795	Snow cover set 2017 RAL 9016
980248	Cylindrical silencer RAL 7016
980250	Cylindrical silencer RAL 9016
915732	Snow cover set SSP RAL 7016
915750	Snow cover set SSP RAL 9016
9150003	Vertical casing for connection line RAL 7016
9150004	Vertical casing for connection line RAL 9016
923488	Screw set for vertical casing VHS

### 28. OTE controller accessories

Part number	Designation
918357	Remote controller, white, with graphic display and humidity sensor FB 6104 RH 2.0
918470	Remote controller with touchscreen and integral web2com server
930303	Room temperature and humidity sensor FT 6224
918272	Auxiliary module OTE 3.0
930165	Sensor set for auxiliary module
290503	Switching relay, buffer tank cross-connection

### 29. Log book

Part number	Designation
982029	Accessories, heat pump service book

# TECHNICAL SPECIFICATIONS

## 30. Medium specification

Part number	Detailed designation
926015	Refrigerant R407c, 3-phase mixture, composition: R134 a > 52% R 125 > 25% R 32 > 23%
	Global warming potential (GWP): 1774
	Refrigerant safety group A1

## 31. Compressor specification AIR 11 C11A

Part number	Detailed designation
910150	Compressor ZH09KVE-TFD-526
	Net weight 29.9 kg
	Length/width/height 243 x 243 x 386 mm
	Supply voltage 380 - 420 V / 3 ~ / 50 Hz
	Maximum operating current 6.5 A
	Blocked rotor current 40.0 A
	Winding resistance 4.68 Ω
	Swept volume 8.0 m <sup>3</sup> /h
	Sound power 73 dBA
926043	Oil type: POE RL32-3MFA (1-litre container)
	Oil volume 1.45 l

## 32. Compressor specification AIR 11 C11B

Part number	Detailed designation
910165	Compressor ZH09KVE-PFZ-526
	Net weight 29.9 kg
	Length/width/height 243 x 243 x 386 mm
	Supply voltage 220 - 240 V / 1~ / 50 Hz
	Maximum operating current 20.8 A
	Blocked rotor current 97.0 A
	Winding resistance 0.69 / 1.65 (R/S) Ω
	Swept volume 8.0 m <sup>3</sup> /h
	Sound power 62.0 dBA
926043	Oil type: POE RL32-3MFA (1-litre container)
	Oil volume 1.45 l

## Notes

---

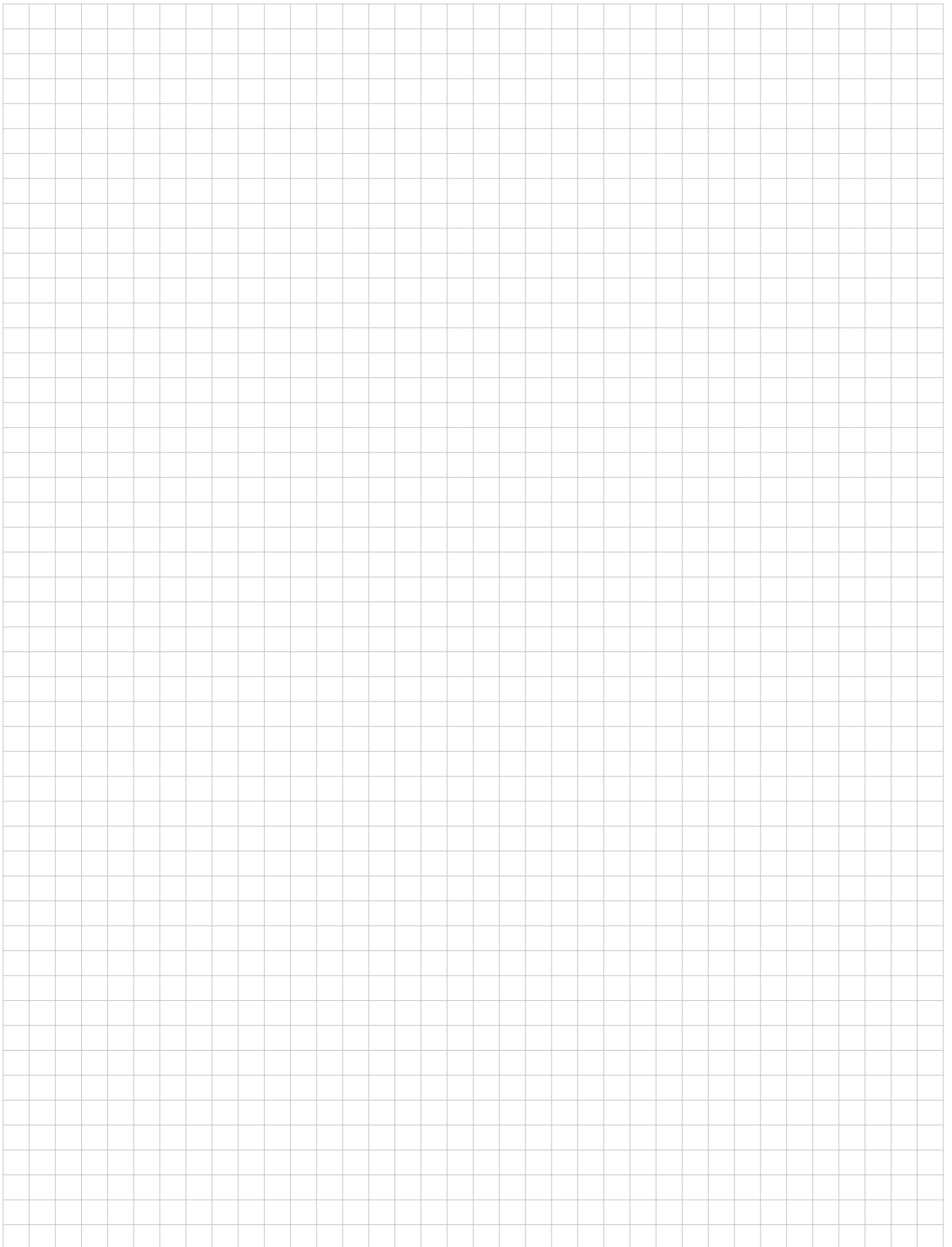

<b>System installer:</b>	
Company	
Address	
Tel. no.	
<b>Service engineer:</b>	

**OCHSNER**  
**Wärmepumpen GmbH Austria**  
(Commercial register)  
Bockgasse 2a  
4021 Linz  
Austria  
kontakt@ochsner.at  
www.ochsner.com

**OCHSNER**  
**Wärmepumpen GmbH Deutschland**  
D-10719 Berlin  
Kurfürstendamm 11  
Hotline for system partners: +49 (0) 1805 832840  
Customer service hotline: +49 (0) 69 256694-495  
kontakt@ochsner.de  
www.ochsner.com

**OCHSNER**  
**Wärmepumpen GmbH Switzerland**  
Uraniastrasse 18  
8001 Zurich  
Switzerland  
Customer service hotline: +41 800 100 911  
kontakt@ochsner.com  
www.ochsner.com

**Head Office/Factory**  
Ochsner-Strasse 1  
3350 Haag  
Austria  
Hotline for system partners: +43 (0) 820 201020  
Customer service hotline: +43 (0) 5 04245-499  
kontakt@ochsner.at  
www.ochsner.com

**OCHSNER East**  
PL 31-302 Kraków  
ul. Pod Fortem Nr. 19  
Tel.: +48 12 4214527  
kontakt@ochsner.pl  
www.ochsner.com

Subject to technical modifications.