



# EUTERM CEILING RADIANT PANELS

**Technical manual**



Version 1906-00

This manual has been edited and printed by CARLIEUKLIMA Srl. Without prior authorization of the manufacturer, it is prohibited to copy it, even partially.

Constant developments to improve our products may cause, without notification, changes to contents and descriptions herein.



In case of disposal, act according to local laws in force.

Radiant panels are made with the following materials:

- steel;
- glass wool.

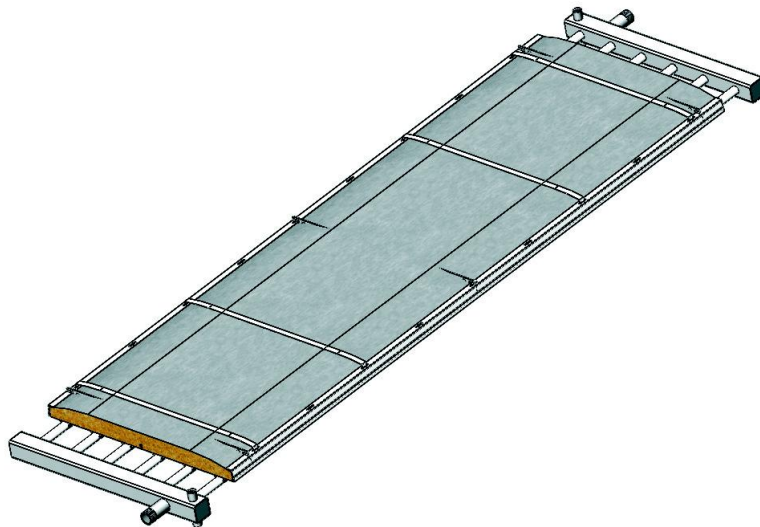
## Sommario

<b>1</b>	<b>CHARACTERISTICS .....</b>	<b>5</b>
1.1	The advantages of EUTERM .....	6
1.2	Components of the EUTERM mounted ceiling radiant panel .....	8
1.3	Technical specifications and available models.....	14
1.4	Thermal output .....	18
1.5	Radiant cooling system and cooling output .....	27
1.6	Pressure drops and surface temperatures.....	32
<b>2</b>	<b>DESIGN .....</b>	<b>36</b>
2.1	Calculation of dispersion.....	36
2.2	Determination of the supply temperature and of the temperature drop of the strip heaters .....	36
2.3	Choice of circuit type .....	37
2.4	Determination of the length of the radiant lines.....	39
2.5	Choice of model of ceiling mounted radiant panel and determination of number of radiant lines .....	39
2.6	Verification of interval between strip heaters .....	40
2.7	Calculation of actual temperature drop and average temperature .....	42
2.8	Calculation of water flow rate and pressure drops.....	43
2.9	Example of design .....	44
2.9.1	Calculation of thermal requirement.....	45
2.9.2	Determination of the supply temperature and of the temperature drop of the ceiling radiant panels .....	45
2.9.3	Choice of circuit type .....	45
2.9.4	Determination of the length of the lines of ceiling mounted ceiling radiant panels.....	46
2.9.5	Choice of model of ceiling mounted radiant panel and determination of number of radiant lines .....	46
2.9.6	Verification of interval between ceiling mounted radiant panels .....	47
2.9.7	Calculation of actual temperature drop and average temperature .....	47
2.9.8	Calculation of water flow rate and pressure drops.....	48
<b>3</b>	<b>INSTALLATION .....</b>	<b>49</b>
3.1	Suspension brackets .....	49
3.1.1	Width of brackets .....	50
3.1.2	Distance between brackets .....	51
3.1.3	Number of anchors .....	51
3.1.4	Length of anchors.....	52
3.2	Types of circuits and types of headers.....	53
3.3	Connection of headers .....	56

3.4	Installation of header covers (accessory supplied on request).....	58
3.5	Lifting the ceiling radiant panels .....	59
3.6	Connection between ceiling radiant panels .....	60
3.7	Assembly of joint covers .....	62
3.8	Installation of the insulating mat on standard panels.....	63
3.9	Installation of the insulating mat on panels with anti-convective aprons (optional) .....	65
3.10	Installation of cover for gyms (optional) on standard panels.....	67
3.11	Installation of cover for gyms (optional) on panels with anti-convective aprons.....	69
3.12	Charging and discharging the system .....	70
3.12.1	Instructions for charging and discharging the system. ....	70
<b>4</b>	<b>TECHNICAL SPECIFICATIONS .....</b>	<b>72</b>
<b>5</b>	<b>DECLARATION OF COMFORMITY .....</b>	<b>73</b>

## 1 CHARACTERISTICS

EUTERM is a radiance heating system composed of ceiling radiant panels that run on hot water, superheated water or steam. In summertime, the EUTERM ceiling radiant panels can be used for cooling with cold water. The high quality of the EUTERM system is guaranteed by the use of choice materials, surface treatments which determine constant thermal output over time, and the choice of accurate manufacturing processes. The shape of the panel is such that it ensures a wide contact between the plate and the tubes, and substantially limits the convective movement of air towards the ceiling, thus increasing the percentage of heat radiated into the room. EUTERM is a simple and quiet heating system, since the transfer of heat from the fluid to the plates and from there to the room does not require any mechanical or electrical parts. Furthermore, EUTERM can run on any hot fluid generated by any sort of energy source. EUTERM is available in numerous models of various length, width and number of tubes. This makes it possible to adapt EUTERM easily to small, medium or large rooms, such as manufacturing, commercial, sports areas and also in buildings where there is the risk of fire. All installation operations are made easier by a simple ceiling fastening system and joints. Maintenance and wear are non-existent, thanks to the use of high-quality materials and the static nature of the system, which does not include any moving electrical or mechanical parts. Compared to the other systems this prevents system downtime and leads to substantial operating savings.



*Fig. 1-1 EUTERM ceiling radiant panel*

## 1.1 The advantages of EUTERM

### **Greater comfort with lower air temperature**

The perception of comfort in a room has to do not only with the air temperature (as is commonly believed) but also with the temperature of the surfaces around the body (main radiant temperature). In a room heated with EUTERM ceiling radiant panels, there is an increase in the main radiant temperature, and therefore, with the same degree of comfort, a reduced temperature of the air, which is transparent to radiance and is heated only upon contact with the floor and other surfaces. The thermal load of the system is thus reduced because energy is not used to heat high volumes of air directly.

### **Lack of thermal gradient resulting in reduced dispersion**

In rooms heated with EUTERM ceiling radiant panels, the lack of a marked thermal gradient reduces air layering and therefore also the thermal load required to heat the rooms.

In a room heated with a conventional system, thermal layering leads to very high temperatures in the upper parts of the room, thus creating a substantial increase in dispersion.

### **No air movement and lack of suspended dust particles**

In convection systems, dust and any other particles which may or may not be harmful due to manufacturing processes are constantly held suspended in the air due to the ventilation which is typical of those kinds of systems.

If a EUTERM system is implemented, there is no air movement. This makes it perfect to use in every building with any kind of manufacturing process.

### **Absolute silence**

EUTERM is a static system with no electrical mechanical moving parts and this guarantees absolute silent in the rooms where it is installed.

### **Safety**

In the EUTERM radiant panel system, the fluid heating system may be placed in an area very distant from the place of installation. This makes it safe for rooms where there are flammable or potentially explosive products.

### **Possibility to heat or cool by zones**

It is possible to heat or cool single rooms or workstations without having to heat the entire room, adjusting the temperature zone-by-zone.

### **Energy savings and concern for the environment**

The advantage of radiant heating is in its higher performance as compared to other systems, with clear fuel savings thanks to:

- lower dispersion due to lower air temperature;
- lower dispersion due to lack of thermal layering;
- possibility to heat by zones, turning the system on only where it is actually required;
- the use of hot fluid generated by any sort of energy source.

The speed with which the system can be brought up to full operating power and the extremely low maintenance costs complete the economic picture of EUTERM system operation.

## 1.2 Components of the EUTERM mounted ceiling radiant panel

The following points provide information concerning the components of the EUTERM ceiling radiant panel (standard version).

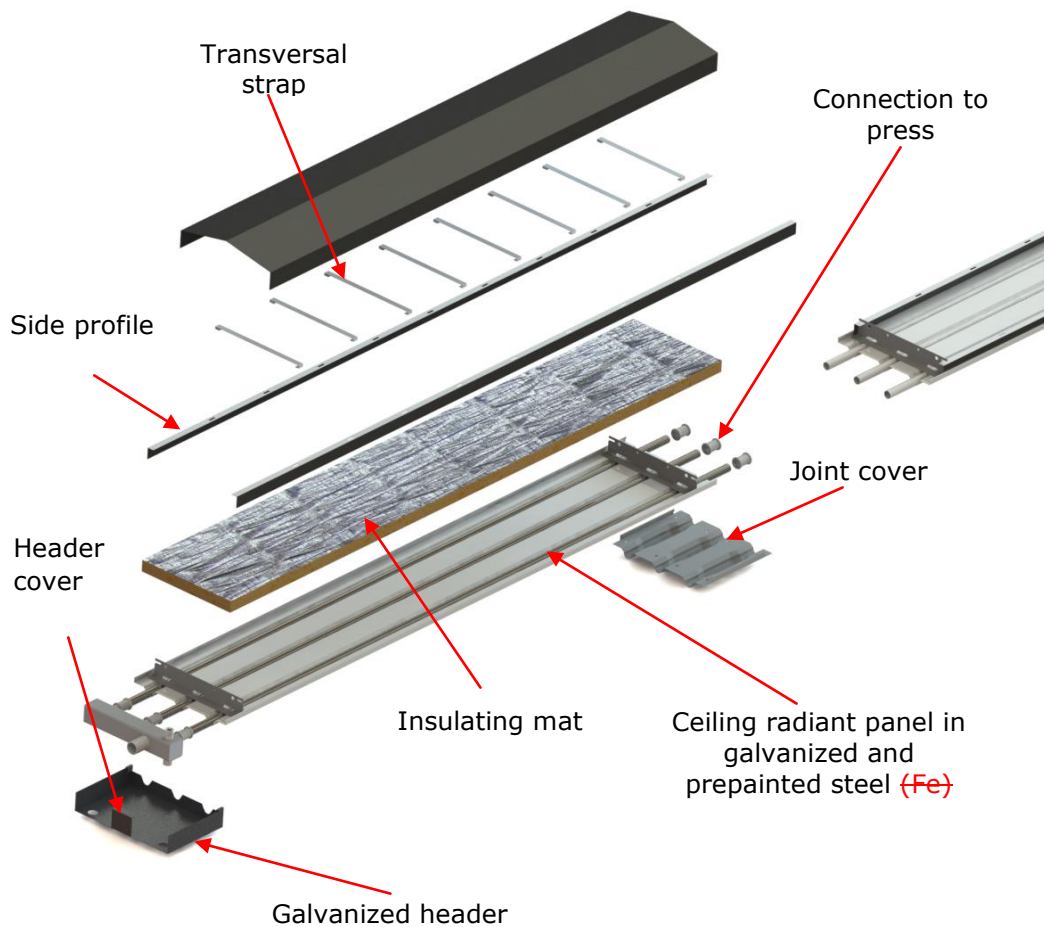


Fig. 1-2 Exploded view of the EUTERM ceiling radiant panel

Radiant sheet with a length of 2.4, or 6 meters and a width of 300, 600, 900 or 1200 mm, made of prepainted galvanized steel with a thickness of 0.6 mm. A special semi-circular shape, with a 100 mm interval, allows the radiant sheet to house the tube measuring 22.0 mm, thus using a large portion of the external area of the tube as a surface for exchange to the plate, hence favoring transfer of heat from the tube to the sheet. The shape also inhibits convective movement which is naturally generated and tends to carry the warm air upwards. The inclination of the side containing surfaces of the tube (as shown in Figure 1.4) makes it possible to direct the rays downwards with an angle of up to 45°, thus increasing the total radiated thermal power downwards and distributing it evenly.

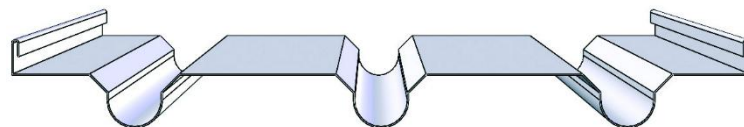
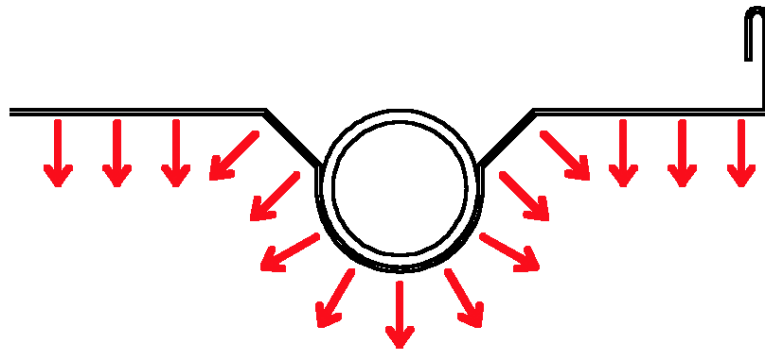
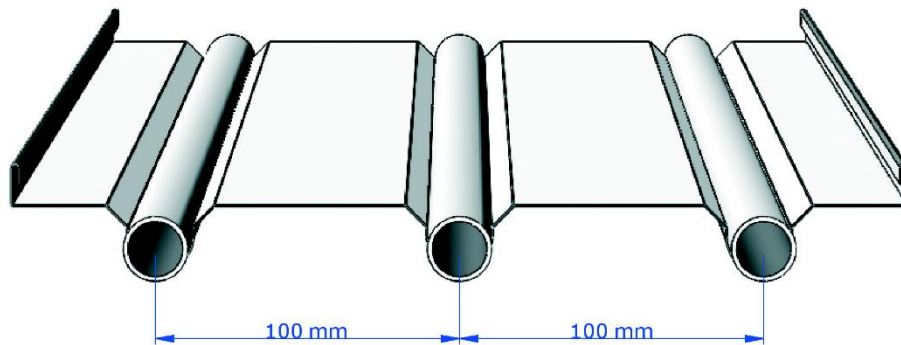


Fig. 1-3 Radiant plate



*Fig. 1-4 Detail of the radiant sheet*

Tubazione standard in acciaio elettrosaldato zincato da 22,0 mm, sottoposto a prove elettroniche sulla saldatura e a prove di pressione. Le estremità dei tubi sono lisce, idonee per i collegamenti con manicotti a pinzare. I pannelli con tubazioni standard si utilizzano per pressioni di esercizio fino a 6 bar e temperatura massima del fluido di 120°C.

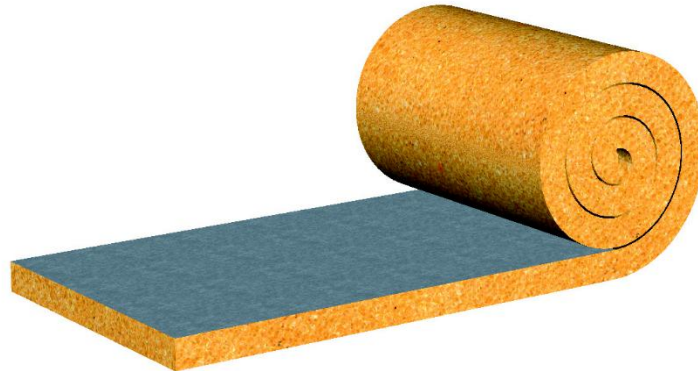


*Fig. 1-5 Radiant sheet and tubes*

The radiant panel is obtained by a profiling process of a steel band, galvanized and prepainted. The standard colour is RAL 9010 and other colours are available on request.

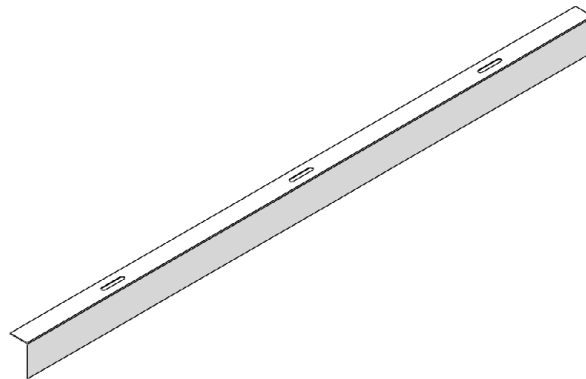
Fiberglass insulating mat, standard thickness 40 mm. Other thicknesses of the insulating mat are available on request.

<b>Thickness</b>	<b>40 mm</b>
Conductivity at 50°C (DIN 52612)	0,036 W/mK
Thermal resistance	1,05 m <sup>2</sup> K/W
Fire class: A2-A1 (EN 13501-1)	



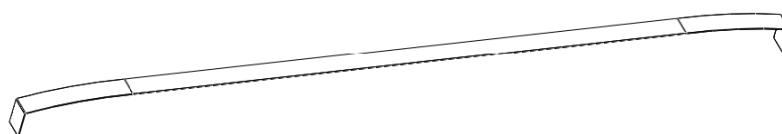
*Fig. 1-6 Insulating mat*

Side profile in prepainted galvanized steel to hold the insulating mat (only for standard version with or without cover for gyms).



*Fig. 1-7 Side to hold the fiberglass*

Transversal strap in galvanized steel to hold the insulating mat.



*Fig. 1-8 Strap*

Headers made with galvanized steel squared tubes measuring 50 x 50 mm, with, on one side 1" threaded attachment (on request 1"1/4) for the connection to the heating circuit, on the other side, smooth cut pipes of a 22.0 mm diameter, fitted for the connection to the radiant panels by means of pressfittings. There is also a hole for air venting, and one which may be used for water discharge. The header is welded and tested in the factory with the pressure indicated by the EN 14037-1,-2,-3.

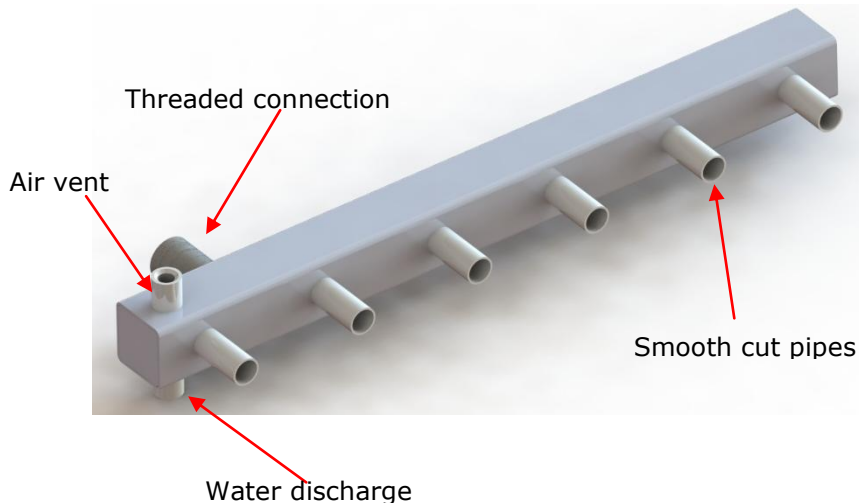


Fig. 1-9 Components of the header

Depending on the type of the supply circuit of the ceiling radiant panels, the header may be of three types:

- **Standard**, with a single attachment, used in installations where the heating fluid inlet and outlet are found on opposite sides of each panel.



- **Diaphragmed**, with a double attachment and an internal diaphragm, used in systems with delivery and return circuits on the same panel.

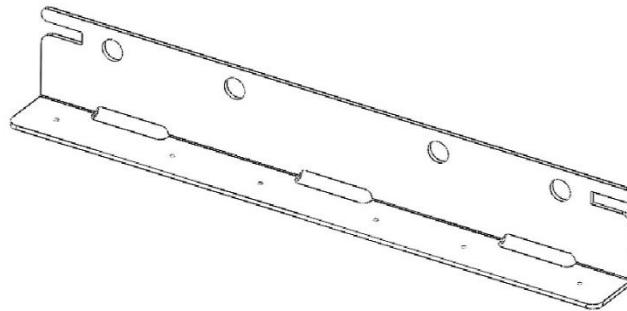


- **Closed**, without attachments, used in systems with delivery and return circuit on the same panel matched to the diaphragmed header (To use with diaphragmed headers).



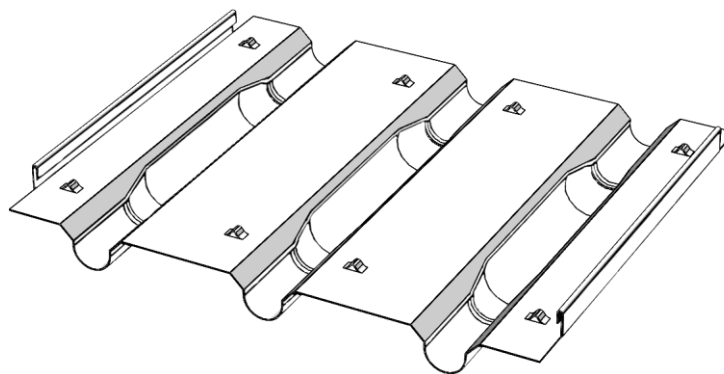
Fig. 1-10 Types of available headers

Galvanized steel support bracket for fastening to the building structure.



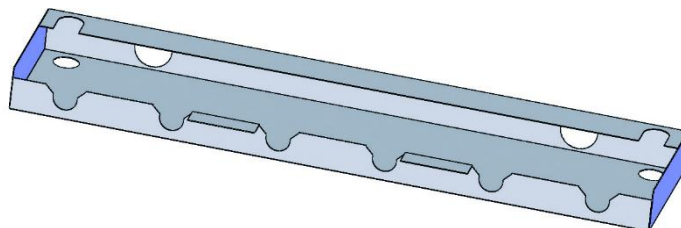
*Fig. 1-11 Support bracket*

Prepainted galvanized steel joint cover for covering the joints between ceiling radiant panels.



*Fig. 1-12 Joint cover*

Prepainted galvanized steel header cover (available on request).



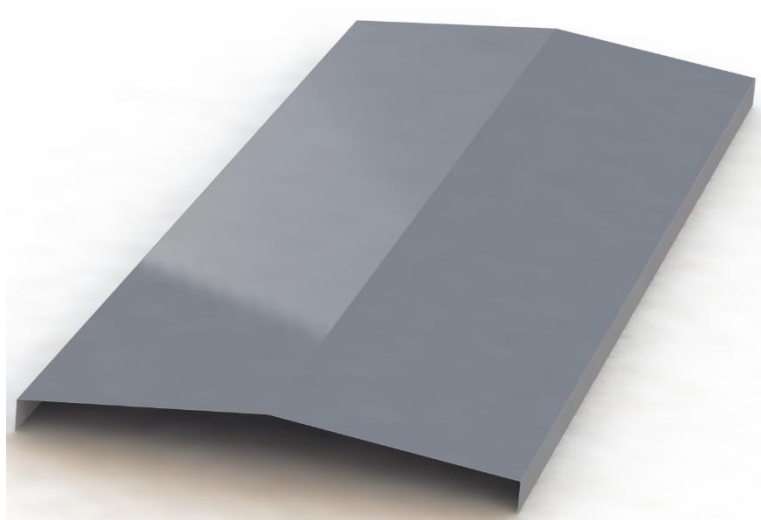
*Fig. 1-13 Header cover*

Side anti-convection apron (available on request).



*Fig. 1-14 Anti-convection apron*

Inclined sheet metal for covering the ceiling radiant panels for installations in gyms or very dusty environments (available on request).



*Fig. 1-15 Cover for gyms*

### 1.3 Technical specifications and available models

The wide range of models of EUTERM ceiling radiant panels makes it possible to heat adequately any type of room based on its height, thermal dispersion, the type of activities performed in the room and the type of supply fluid. Tables 1.1 and 1.2 and Figures 1.16 and 1.17 show the characteristics of the models of ceiling radiant panels and headers available.

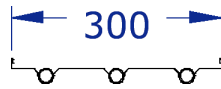
	MODEL	LENGTH [mm]	WIDTH [mm]	NO. TUBES	EMPTY WEIGHT [kg/m] Thickness of tube 1,2 mm	WATER CONTENT [l/m] Thickness of tube 1,2 mm
<b>EUTERM AVH</b>	300/3/2000	2000				
	300/3/4000	4000	300	3	5,4	0,9
	300/3/6000	6000				
	600/6/2000	2000				
	600/6/4000	4000	600	6	9,5	1,8
	600/6/6000	6000				
	900/9/2000	2000				
	900/9/4000	4000	900	9	13,7	2,7
	900/9/6000	6000				
	1200/12/2000	2000				
	1200/12/4000	4000	1200	12	16,6	3,6
	1200/12/6000	6000				
Max. operative pressure 6 bar				Max. water temperature 120°C		
<b>EUTERM AVL</b>	300/2/2000	2000				
	300/2/4000	4000	300	2	4,7	0,6
	300/2/6000	6000				
	600/4/2000	2000				
	600/4/4000	4000	600	4	8,3	1,2
	600/4/6000	6000				
	900/6/2000	2000				
	900/6/4000	4000	900	6	11,8	1,8
	900/6/6000	6000				
	1200/8/2000	2000				
	1200/8/4000	4000	1200	8	16,1	2,4
	1200/8/6000	6000				

Tab. 1-1 Technical data and available models of EUTERM ceiling radiant panels

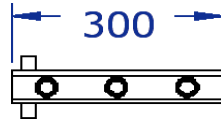
	Length [mm]	Number of pipes	Number of inlet/outlet	No. of connec. for venting/emp tying	Diaphragm	Empty weight [kg]	Water content [l]
Standard header ST. H 300/3	300	3	1	2	-	1.3	0.7
Standard header ST. H 600/6	600	6	1	2	-	2.2	1.3
Standard header ST. H 900/9	900	9	1	2	-	3.2	1.9
Standard header ST. H 1200/12	1200	12	1	2	-	4.1	2.6
Standard header ST. L 300/2	300	2	1	2	-	1.3	0.7
Standard header ST. L 600/4	600	4	1	2	-	2.1	1.3
Standard header ST. L 900/6	900	6	1	2	-	3.1	1.9
Standard header ST. L 1200/8	1200	8	1	2	-	4.0	2.6
Diaphragmed header DI. H 300/3	300	3	2	4	Si	1.6	0.8
Diaphragmed header DI. H 600/6	600	6	2	4	Si	2.5	1.4
Diaphragmed header DI. H 900/9	900	9	2	4	Si	3.5	2.0
Diaphragmed header DI. H 1200/12	1200	12	2	4	Si	4.4	2.6
Diaphragmed header DI. L 300/2	300	2	2	4	Si	1.6	0.8
Diaphragmed header DI. L 600/4	600	4	2	4	Si	2.5	1.4
Diaphragmed header DI. L 900/6	900	6	2	4	Si	3.4	2.0
Diaphragmed header DI. L 1200/8	1200	8	2	4	Si	4.3	2.6
Closed header CI. H 300/3	300	3	-	2	-	1.1	0.6
Closed header CI. H 600/6	600	6	-	2	-	2.0	1.3
Closed header CI. H 900/9	900	9	-	2	-	2.9	1.9
Closed header CI. H 1200/12	1200	12	-	2	-	3.9	2.5
Closed header CI. L 300/2	300	2	-	2	-	1.1	0.6
Closed header CI. L 600/4	600	4	-	2	-	1.9	1.3
Closed header CI. L 900/6	900	6	-	2	-	2.9	1.9
Closed header CI. L 1200/8	1200	8	-	2	-	3.8	2.5

Tab. 1-2 Technical data and available models of EUTERM headers

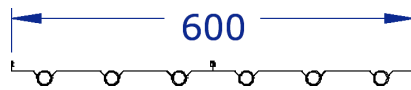
EUTERM AVH 300/3/2000, AVH 300/3/4000, AVH 300/3/6000



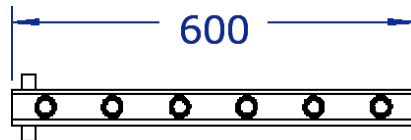
ST. H 300/3



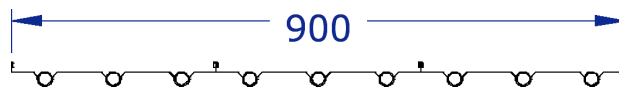
EUTERM AVH 600/6/2000, AVH 600/6/4000, AVH 600/6/6000



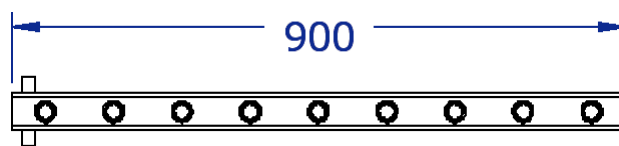
ST. H 600/6, DI. H 600/6, CI. H 600/6



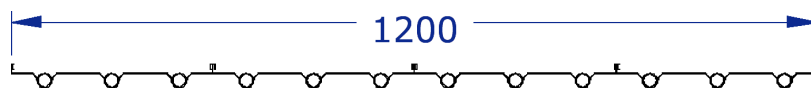
EUTERM AVH 900/9/2000, AVH 900/9/4000, AVH 900/9/6000



ST. H 900/9, DI. H 900/9, CI. H 900/9



EUTERM AVH 1200/12/2000, AVH 1200/12/4000, AVH 1200/12/6000



ST. H 1200/12, DI. H 1200/12, CI. H 1200/12

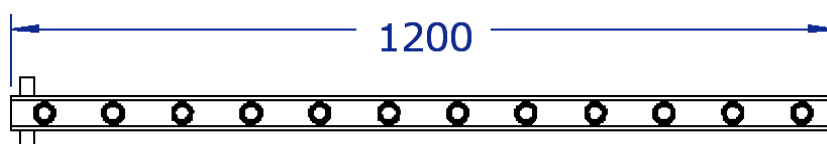
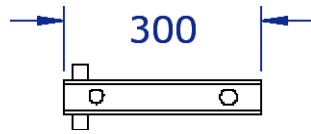


Fig. 1.16 EUTERM AVH models and relative headers

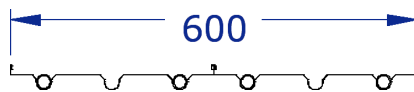
EUTERM AVL 300/2/2000, AVL 300/2/4000, AVL 300/2/6000



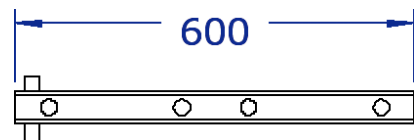
ST. L 300/2



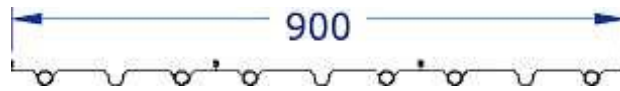
EUTERM AVL 600/4/2000, AVL 600/4/4000, AVL 600/4/6000



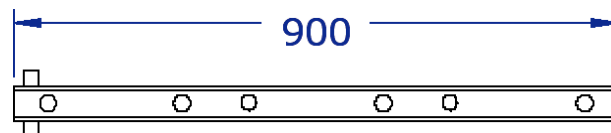
ST. L 600/4, DI. L 600/4, CI. L 600/4



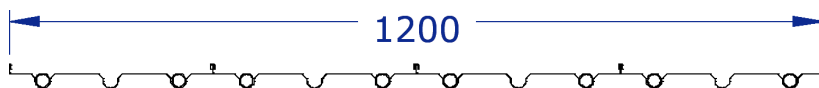
EUTERM AVL 900/6/2000, AVL 900/6/4000, AVL 900/6/6000



ST. L 900/6, DI. L 900/6, CI. L 900/6



EUTERM AVL 1200/8/2000, AVL 1200/8/4000, AVL 1200/8/6000



ST. L 1200/8, DI. L 1200/8, CI. L 1200/8

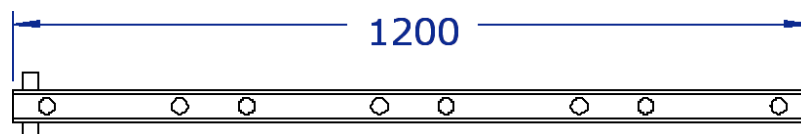


Fig. 1.17 EUTERM AVL models and relative headers

## 1.4 Thermal output

Figures 1.18 and 1.20 show the thermal emission values of the EUTERM ceiling radiant panels, operating with hot or superheated water. They refer to ceiling installation in a horizontal position, with the upper part insulated and an installation height of 5 m in warehouses with a normal structure, with no forced or natural ventilation, without any particular opening in the roof.

**The following symbols are used in the graph:**

$T_M$  = Average temperature of the thermal fluid (average between the temperature of the fluid at the inlet header and the temperature at the outlet header) [°C]

$T_O$  = Operative room temperature, measured with a globe thermometer [°C]

$\Delta T = T_M - T_O$  [°C]

The thermal output of the ceiling radiant panels EUTERM have been certified on the credited laboratory HLK of the University of Stuttgart in compliance with the European norm EN14037.

Equation used to calculate the thermal output:

$$\Phi = K * \Delta T^n$$

$\Phi$  = Thermal output

$K$  = Coefficient related to the heating body

$v$  = Exponent related to the heating body

$\Delta T$  = difference between the average temperature of the thermal fluid and the operative room temperature

Data indicated on the following tables and figures represent the thermal output considering different working conditions, identified by the difference between the average temperature of the thermal fluid and the operative room temperature ( $\Delta T$ ).

Basic values obtained by the HLK laboratory, derived with a  $\Delta T = 55K$

### Radiant panels:

Model	Thermal Output (W/m)	Coefficient K	Exponent n
AVH 300	201	1.7846	1.1835
AVH 600	373	3.1016	1.1951
AVH 900	519	4.392	1.191
AVH 1200	665	5.7245	1.1867

### Headers:

Model	Thermal Output (W/m)	Coefficient K	Exponent n
AVH 300	32	6.0994	0.4135
AVH 600	58	11.2602	0.4103
AVH 900	89	17.1289	0.4121
AVH 1200	119	22.7281	0.4140

$\Delta T$	Model AVH 300	Model AVH 600	Model AVH 900	Model AVH 1200
[K]	[W/m]	[W/m]	[W/m]	[W/m]
30	98	181	252	324
32	106	195	272	350
34	114	210	293	376
36	121	225	313	402
38	130	240	334	429
40	138	255	355	456
42	146	270	377	483
44	154	286	398	511
46	162	301	420	538
48	171	317	442	566
50	179	333	464	594
52	188	349	486	622
54	196	365	508	651
55	201	373	519	665
56	205	381	531	680
58	214	397	553	709
60	222	414	576	738
62	231	430	599	767
64	240	447	622	796
66	249	464	645	826
68	258	480	669	856
70	267	497	692	886
72	276	514	716	916
74	285	532	739	946
76	294	549	763	977
78	303	566	787	1007
80	313	583	811	1038
82	322	601	836	1069
84	331	618	860	1100
86	341	636	884	1131
88	350	654	909	1162
90	359	672	934	1194
92	369	689	958	1225
94	378	707	983	1257
96	388	725	1008	1289
98	397	744	1033	1320
100	407	762	1058	1353
102	417	780	1084	1385
104	426	798	1109	1417
106	436	817	1134	1449
108	446	835	1160	1482
110	456	854	1186	1514
112	466	872	1211	1547
114	475	891	1237	1580
116	485	910	1263	1613
118	495	928	1289	1646
120	505	947	1315	1679
122	515	966	1341	1712
124	525	985	1368	1746
126	535	1004	1394	1779
128	545	1023	1420	1813
130	555	1042	1447	1847
132	565	1061	1473	1880
134	576	1081	1500	1914
136	586	1100	1527	1948
138	596	1119	1553	1982
140	606	1139	1580	2016
142	616	1158	1607	2050
144	627	1178	1634	2085
146	637	1197	1661	2119
148	647	1217	1688	2154
150	658	1237	1715	2188

In according to EN 14037 -1, -2, -3

Tab. 1-3 Thermal output [W/m] for EUTERM ceiling radiant panels AVH

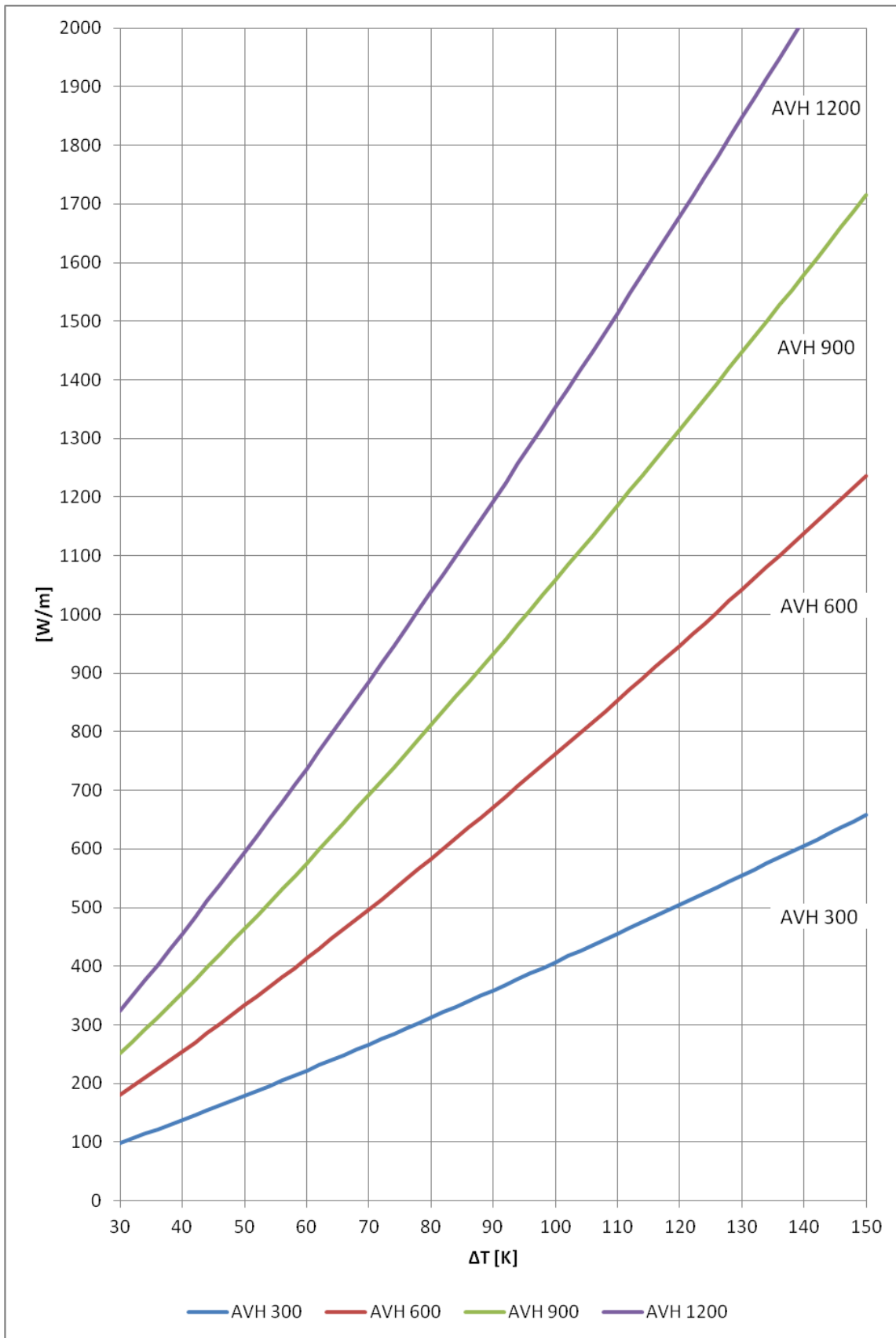


Fig. 1.18 Thermal output for EUTERM AVH in according to EN 14037-1,2,3.

<b>ΔT</b>	<b>Header for AVH 300</b>	<b>Header for AVH 600</b>	<b>Header for AVH 900</b>	<b>Header for AVH 1200</b>
<b>[K]</b>	<b>[W]</b>	<b>[W]</b>	<b>[W]</b>	<b>[W]</b>
30	25	45	70	93
32	26	47	71	95
34	26	48	73	98
36	27	49	75	100
38	27	50	77	102
40	28	51	78	105
42	29	52	80	107
44	29	53	81	109
46	30	54	83	111
48	30	55	84	113
50	31	56	86	115
52	31	57	87	117
54	32	58	89	119
55	32	58	89	119
56	32	59	90	120
58	33	60	91	122
60	33	60	93	124
62	34	61	94	125
64	34	62	95	127
66	34	63	96	129
68	35	64	97	130
70	35	64	99	132
72	36	65	100	134
74	36	66	101	135
76	37	67	102	137
78	37	67	103	138
80	37	68	104	139
82	38	69	105	141
84	38	69	106	142
86	38	70	107	144
88	39	71	108	145
90	39	71	109	146
92	40	72	110	148
94	40	73	111	149
96	40	73	112	150
98	41	74	113	152
100	41	74	114	153
102	41	75	115	154
104	42	76	116	155
106	42	76	117	157
108	42	77	118	158
110	43	77	119	159
112	43	78	120	160
114	43	79	121	161
116	44	79	121	163
118	44	80	122	164
120	44	80	123	165
122	44	81	124	166
124	45	81	125	167
126	45	82	126	168
128	45	82	127	169
130	46	83	127	171
132	46	83	128	172
134	46	84	129	173
136	47	85	130	174
138	47	85	130	175
140	47	86	131	176
142	47	86	132	177
144	48	87	133	178
146	48	87	134	179
148	48	87	134	180
150	48	88	135	181

In riferimento alla EN 14037 -1, -2, -3

Tab. 1-4 Thermal output [W] for EUTERM AVH headers

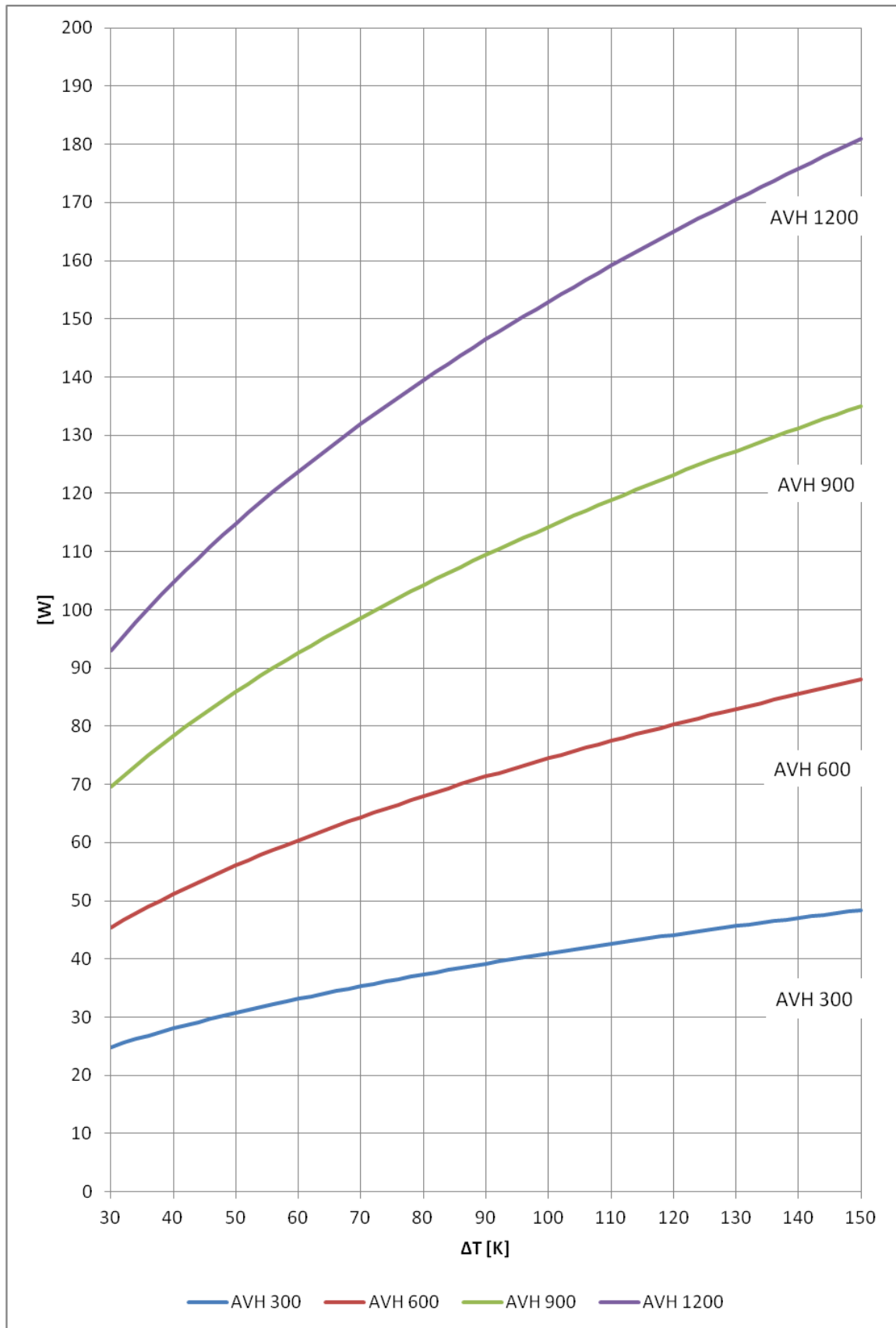


Fig. 1.19 Thermal output for EUTERM AVH headers in according to EN 14037-1,2,3.

$\Delta T$	Model AVL 300	Model AVL 600	Model AVL 900	Model AVL 1200
[K]	[W/m]	[W/m]	[W/m]	[W/m]
30	86	155	214	273
32	92	167	231	294
34	99	179	248	316
36	106	192	265	338
38	112	204	282	360
40	119	217	300	382
42	126	230	318	405
44	132	242	335	427
46	139	255	353	450
48	146	268	371	473
50	153	281	389	497
52	160	294	408	520
54	167	308	426	544
55	170	314	435	555
56	174	321	445	567
58	181	334	463	591
60	188	348	482	615
62	195	361	501	639
64	202	375	520	664
66	209	388	539	688
68	216	402	558	713
70	223	416	577	737
72	230	430	597	762
74	238	444	616	787
76	245	458	636	812
78	252	472	655	837
80	260	486	675	862
82	267	500	695	888
84	274	514	715	913
86	282	529	735	939
88	289	543	755	964
90	296	557	775	990
92	304	572	795	1016
94	311	586	815	1042
96	319	601	836	1068
98	326	616	856	1094
100	334	630	876	1121
102	341	645	897	1147
104	349	660	918	1173
106	356	674	938	1200
108	364	689	959	1227
110	372	704	980	1253
112	379	719	1001	1280
114	387	734	1022	1307
116	394	749	1043	1334
118	402	764	1064	1361
120	410	779	1085	1388
122	417	794	1106	1415
124	425	810	1127	1442
126	433	825	1149	1470
128	441	840	1170	1497
130	448	855	1191	1525
132	456	871	1213	1552
134	464	886	1234	1580
136	472	901	1256	1608
138	480	917	1278	1635
140	487	932	1299	1663
142	495	948	1321	1691
144	503	963	1343	1719
146	511	979	1365	1747
148	519	995	1387	1775
150	527	1010	1409	1804

Tab. 1-5 Thermal output [W/m] for EUTERM AVL

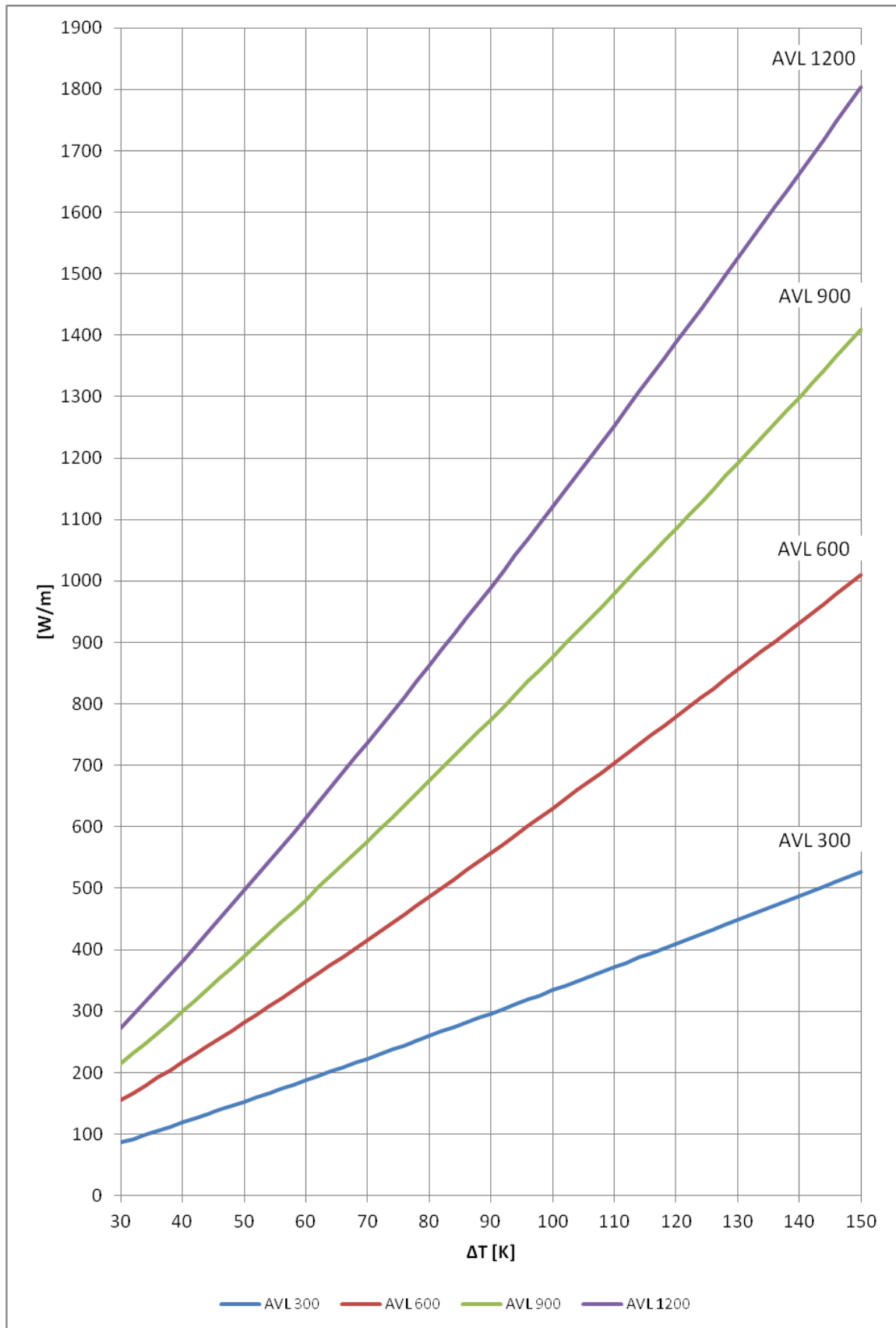


Fig. 1.20 Thermal output for EUTERM AVL

$\Delta T$	Header for AVL 300	Header for AVL 600	Header for AVL 900	Header for AVL 1200
[K]	[W]	[W]	[W]	[W]
30	24	43	66	88
32	24	44	68	91
34	25	45	70	93
36	26	47	71	95
38	26	48	73	97
40	27	49	74	99
42	27	50	76	101
44	28	51	77	103
46	28	51	79	105
48	29	52	80	107
50	29	53	82	109
52	30	54	83	111
54	30	55	84	113
<b>55</b>	30	55	85	113
56	31	56	85	114
58	31	57	87	116
60	31	57	88	118
62	32	58	89	119
64	32	59	90	121
66	33	60	91	122
68	33	60	93	124
70	34	61	94	125
72	34	62	95	127
74	34	63	96	128
76	35	63	97	130
78	35	64	98	131
80	35	65	99	132
82	36	65	100	134
84	36	66	101	135
86	37	67	102	137
88	37	67	103	138
90	37	68	104	139
92	38	68	105	140
94	38	69	106	142
96	38	70	107	143
98	39	70	108	144
100	39	71	109	145
102	39	71	109	147
104	40	72	110	148
106	40	72	111	149
108	40	73	112	150
110	40	74	113	151
112	41	74	114	152
114	41	75	115	153
116	41	75	115	155
118	42	76	116	156
120	42	76	117	157
122	42	77	118	158
124	43	77	119	159
126	43	78	119	160
128	43	78	120	161
130	43	79	121	162
132	44	79	122	163
134	44	80	122	164
136	44	80	123	165
138	44	81	124	166
140	45	81	125	167
142	45	82	125	168
144	45	82	126	169
146	45	83	127	170
148	46	83	128	171
150	46	84	128	172

Tab. 1.6 Thermal output [W] for EUTERM AVL headers

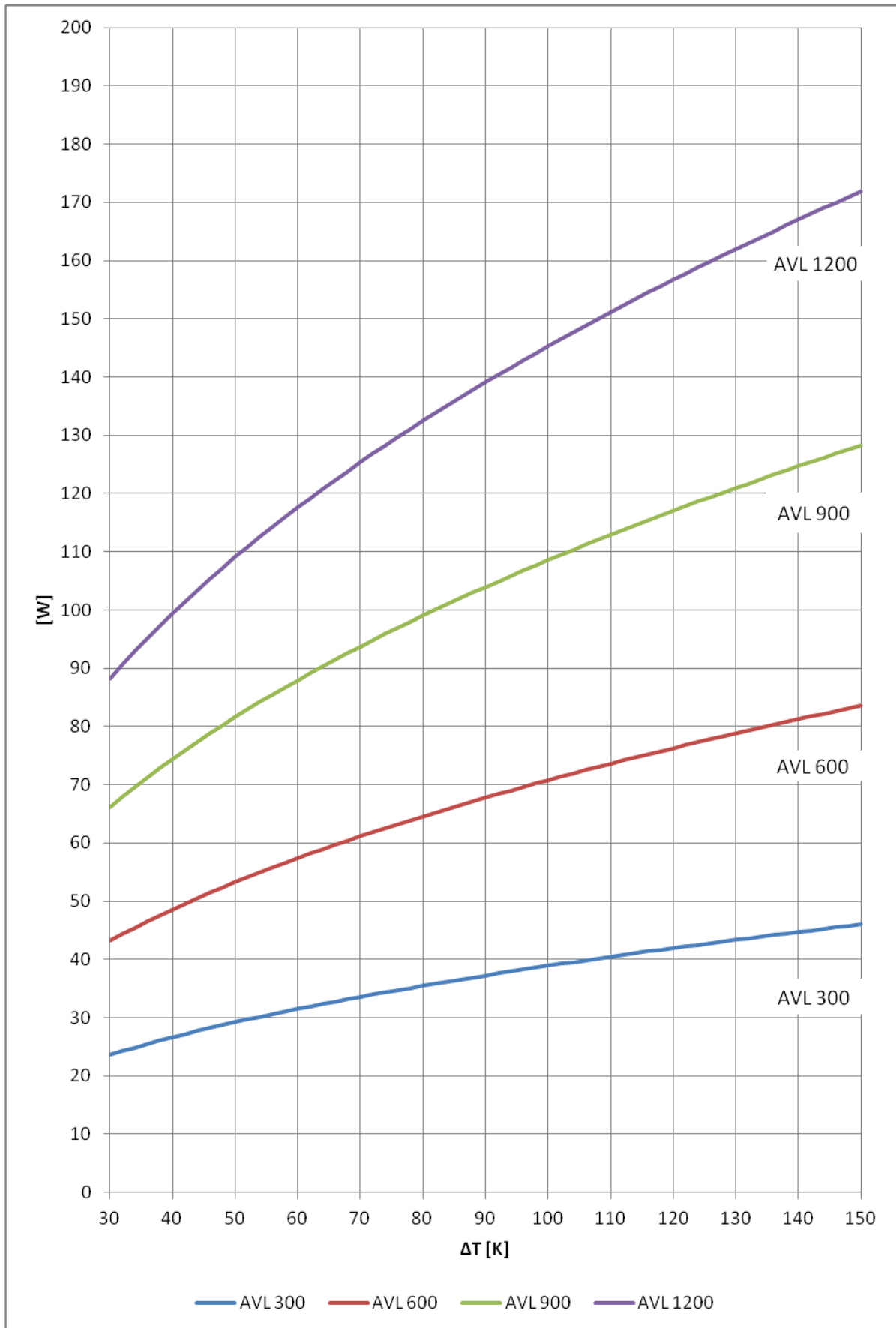


Fig. 1.21 Thermal output for EUTERM AVL headers

## 1.5 Radiant cooling system and cooling output

In order to improve the living and work-conditions, the air conditioning is now a necessary requirement for the environmental comfort. It is demonstrable and easy to guess that the insufficient environmental wellness with high damp and temperature levels influence the productive capacity. The unfavourable environmental conditions can decrease the productivity from 10% to 20%.

With an adequate management, the ceiling radiant panels EUTERM by CARLIEUKLIMA can be used also as a cooling system, helping to increase the environmental comfort, as well, during summertime, apart from the winter period.

The same advantages of radiance are valid also for cooling version. Compared to a classic cooling system, they increase the environmental comfort and the economic advantage.

### Advantages of environmental comfort

- Keeping more high air temperature.

Considering that the operating temperature ( $T_{op}$ ) is the average temperature between the air temperature ( $T_a$ ) and the walls temperature ( $T_p$ ) is valid as follow:

For example, to obtain a project temperature of 25°C you can have the following conditions:

$$T_{op} \text{ of } 25^{\circ}\text{C} = \frac{T_a (23^{\circ}\text{C}) + T_p (27^{\circ}\text{C})}{2}$$

(with a traditional cooling system)

$$T_{op} \text{ of } 25^{\circ}\text{C} = \frac{T_a (27^{\circ}\text{C}) + T_p (23^{\circ}\text{C})}{2}$$

(with radiant cooling system)

The radiance cooling permits to have the requested operating temperature, keeping the air temperature higher than a traditional cooling system, increasing noticeably the environmental comfort.

- Environment air speed and hygiene

As already described for the radiant heating system, also in case of cooling there are not air movement, since the convective actions are totally absent.

In fact, in the areas where cooling system as EUTERM are used, the air movements are attributed only to the air-change or to tamp control systems.

The lack of air movements and then the lack of dust movements, make the places cooled by EUTERM more clean and healthy.

- Silente

Since there are not mechanical moving parts placed in the environment, this system is absolutely quiet.

## Introduction

A very important point of this kind of system, is the necessity to avoid that the temperature of radiant surface will be lower than the dew temperature of surrounding areas, in order to avoid the condensate on radiance surface.

It must be considered that, in areas where there is not any conditioning of air, the dew point of the environmental air is the same of the outdoor air. In this case, it is advised to keep the inlet water temperature in the ceiling panel, 1 °C higher than the dew temperature of the conditioned area.

## Cooling output of the ceiling radiant panels EUTERM

The cooling output of the ceiling radiant panels EUTERM have been certified on the credited laboratory HLK of the University of Stuttgart in compliance with what is prescribed by the European norm EN14240.

Equation used to calculate the cooling output:

$$\Phi = K * \Delta T^n$$

$\Phi$  = Cooling yield

K = Coefficient related to the cooling body

n = Exponent related to the cooling body

$\Delta T$  = difference between the average temperature of the thermal fluid and the operative room temperature

Data indicated on the previous tables and figures represent the cooling output considering different working conditions, identified by the difference between the average temperature of the thermal fluid and the operative room temperature ( $\Delta T$ ).

Basic values obtained by the HLK laboratory, derived with a  $\Delta T = 8K$

Model	Thermal Output (W/m)	Coefficient K	Exponent n
AVH 300	27	2.7414	1.0967

	Model AVH 300	Model AVH 600	Model AVH 900	Model AVH 1200
<b>ΔT</b>				
<b>[K]</b>	<b>[W/m]</b>	<b>[W/m]</b>	<b>[W/m]</b>	<b>[W/m]</b>
1	3	6	8	10
2	6	11	16	20
3	9	17	23	30
4	13	24	34	43
5	16	30	41	53
6	20	37	52	66
7	23	43	60	76
8	27	50	70	89
9	31	57	80	102
10	34	63	88	112
11	38	70	98	125
12	42	78	109	139
13	46	85	119	152
14	50	93	130	165
15	53	98	137	175

In according to EN 14240

Tab. 1.7 cooling output [W/m] for EUTERM AVH

	Model AVL 300	Model AVL 600	Model AVL 900	Model AVL 1200
<b>ΔT</b>				
<b>[K]</b>	<b>[W/m]</b>	<b>[W/m]</b>	<b>[W/m]</b>	<b>[W/m]</b>
1	2	4	5	7
2	5	9	13	17
3	8	15	21	26
4	10	19	26	33
5	13	24	34	43
6	16	30	41	53
7	19	35	49	63
8	22	41	57	73
9	25	46	65	83
10	29	54	75	96
11	32	59	83	106
12	35	65	91	116
13	38	70	98	125
14	41	76	106	135
15	45	83	117	149

Tab. 1.8 cooling output [W/m] for EUTERM AVL

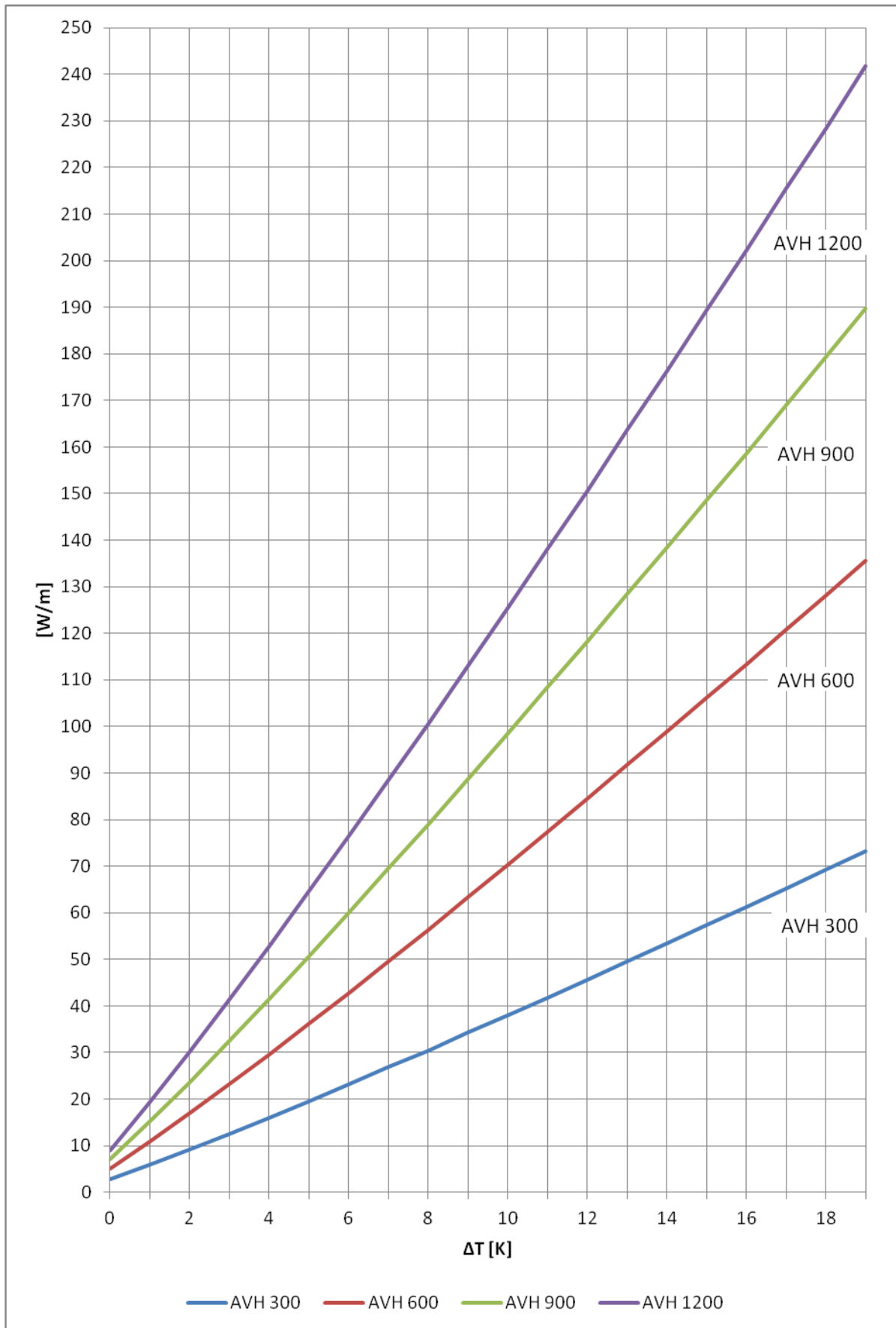


Fig. 1.22 Cooling output for EUTERM AVH ceiling radiant panels in according to EN 14240

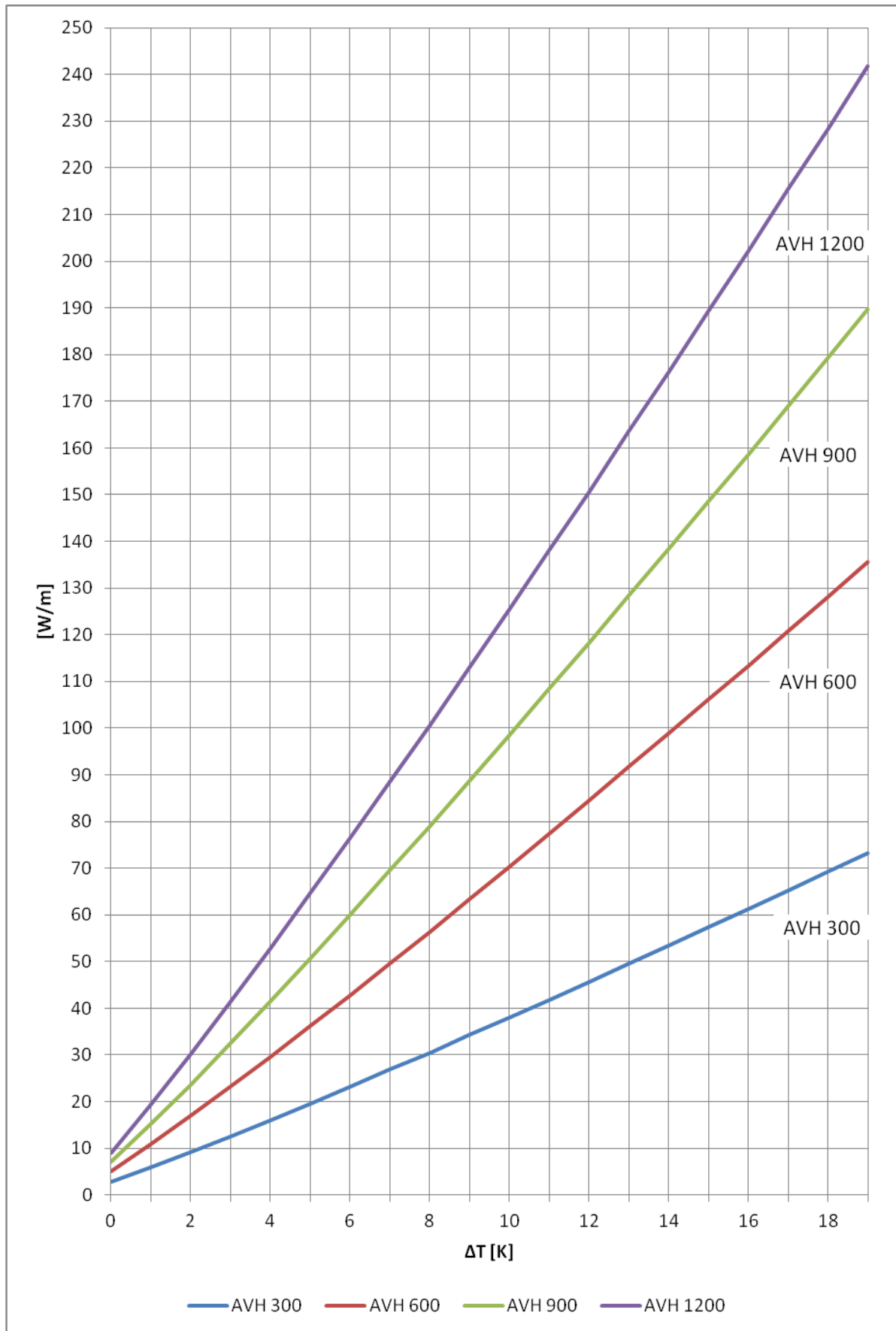


Fig. 1.23 Cooling output for EUTERM AVL ceiling radiant panels

## 1.6 Pressure drops and surface temperatures

The graphs showing the pressure drops of the EUTERM ceiling radiant panels, refer to an average TM temperature of the fluid equal to 80°C; for other temperature, the corrective coefficient  $\beta$  is used, which multiplies the total pressure drops obtained from the diagrams shown in Figures 1.24, 1.25, 1.26, 1.27, 1.28. Figure 1.29 shows the average temperature reached on the surface of the ceiling radiant panels when the average water temperature is changed.

TM [°C]	60	80	100	120	140	160
Coefficient $\beta$	1.08	1.00	0.95	0.90	0.86	0.82

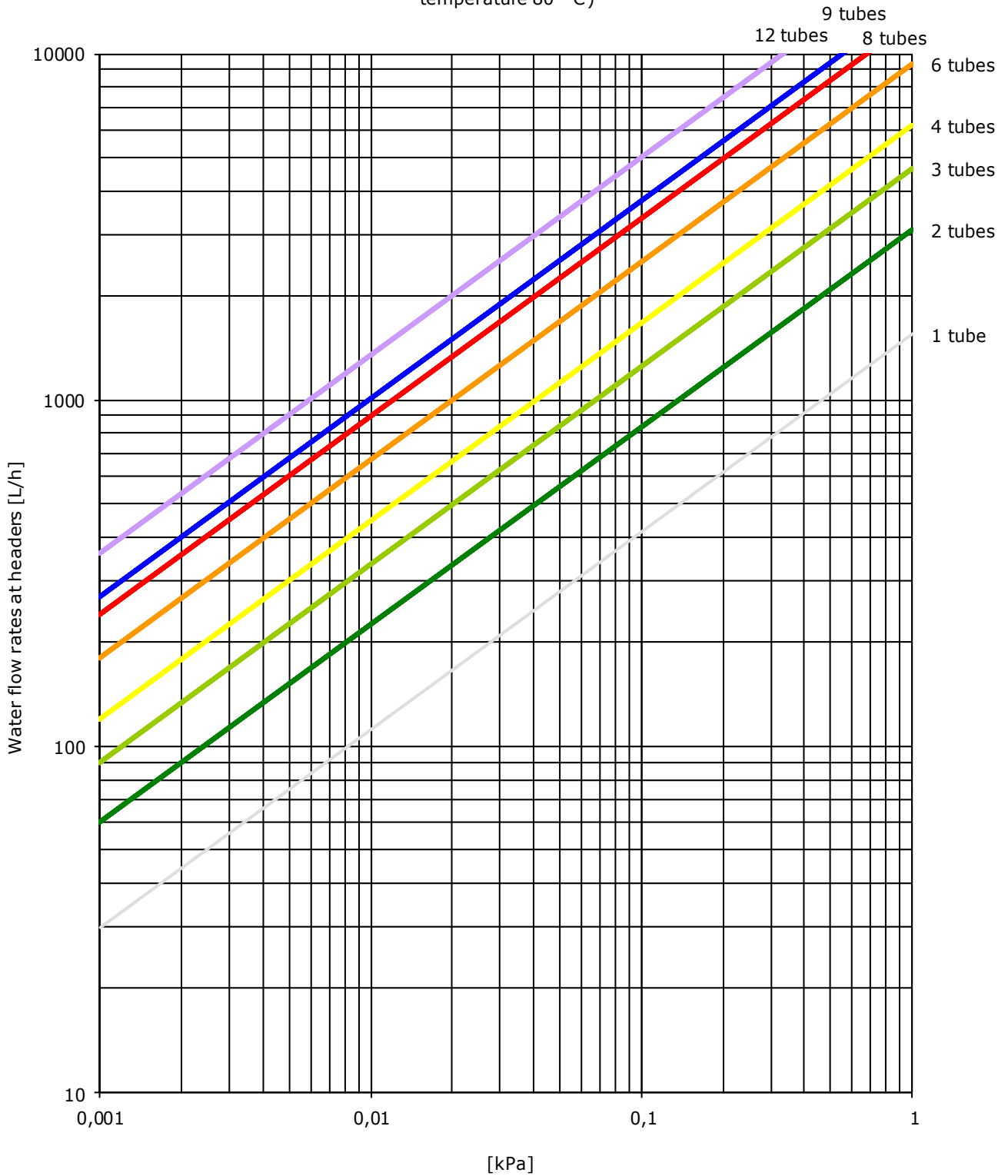
Tab. 1.9 Corrective coefficients for pressure drops based on average water temperature

It is advisable to use water flow rate values inclusive between 200 and 400 l/h for each tube (D = 22.0 mm) of the EUTERM ceiling radiant panel. Table 1.9 shows the minimum flow rate values. It is absolutely imperative not to drop below these in order to have a turbulent movement of the fluid in the tube, thus ensuring a high thermal exchange coefficient.

	Return Temperature [°C]	L				H				
		L 300/2	L 600/4	L 900/6	L 1200/8	H 300/3	H 600/6	H 900/9	H 1200/12	
<b>ST. HEADER.</b>	<b>Minimum water flow rate l/h</b>									
	<b>30</b>	241	482	724	965	362	724	1085	1447	
	<b>40</b>	197	395	592	789	296	592	888	1184	
	<b>50</b>	165	329	494	659	247	494	741	988	
	<b>60</b>	140	279	419	558	209	419	628	838	
	<b>70</b>	120	240	360	480	180	360	540	720	
	<b>80</b>	104	209	313	417	156	313	469	626	
	<b>90</b>	92	183	275	366	137	275	412	549	
	<b>100</b>	81	162	243	324	122	243	365	486	
	<b>110</b>	72	144	217	289	108	217	325	433	
	<b>120</b>	65	130	194	259	97	194	292	389	
	<b>130</b>	58	117	175	234	88	175	263	351	
	<b>140</b>	53	106	159	212	80	159	239	318	
	<b>150</b>	48	97	145	193	72	145	217	290	
	<b>DI. HEADER</b>	<b>30</b>	121	241	362	482	241	362	603	724
<b>40</b>		99	197	296	395	197	296	493	592	
<b>50</b>		82	165	247	329	165	247	412	494	
<b>60</b>		70	140	209	279	140	209	349	419	
<b>70</b>		60	120	180	240	120	180	300	360	
<b>80</b>		52	104	156	209	104	156	261	313	
<b>90</b>		46	92	137	183	92	137	229	275	
<b>100</b>		41	81	122	162	81	122	203	243	
<b>110</b>		36	72	108	144	72	108	181	217	
<b>120</b>		32	65	97	130	65	97	162	194	
<b>130</b>		29	58	88	117	58	88	146	175	
<b>140</b>		27	53	80	106	53	80	133	159	
<b>150</b>		24	48	72	97	48	72	121	145	

Tab. 1.10 Minimum water flow rate in function of kind of headers and return temperature

Pressure drop per linear meter of radiant panel with 22.0x1.2 pipe standard header (average temperature 80 °C)



1 kPa = 10 hPa = 10 mbar = 100 mm H<sub>2</sub>O

Fig. 1.24 Pressure drops per linear meter of radiant panel with standard tube and standard header (average temperature 80°C)

Pressure drop per linear meter of radiant panel with 22.0x1.2 pipe diaphragmed header (average temperature 80 ° C)

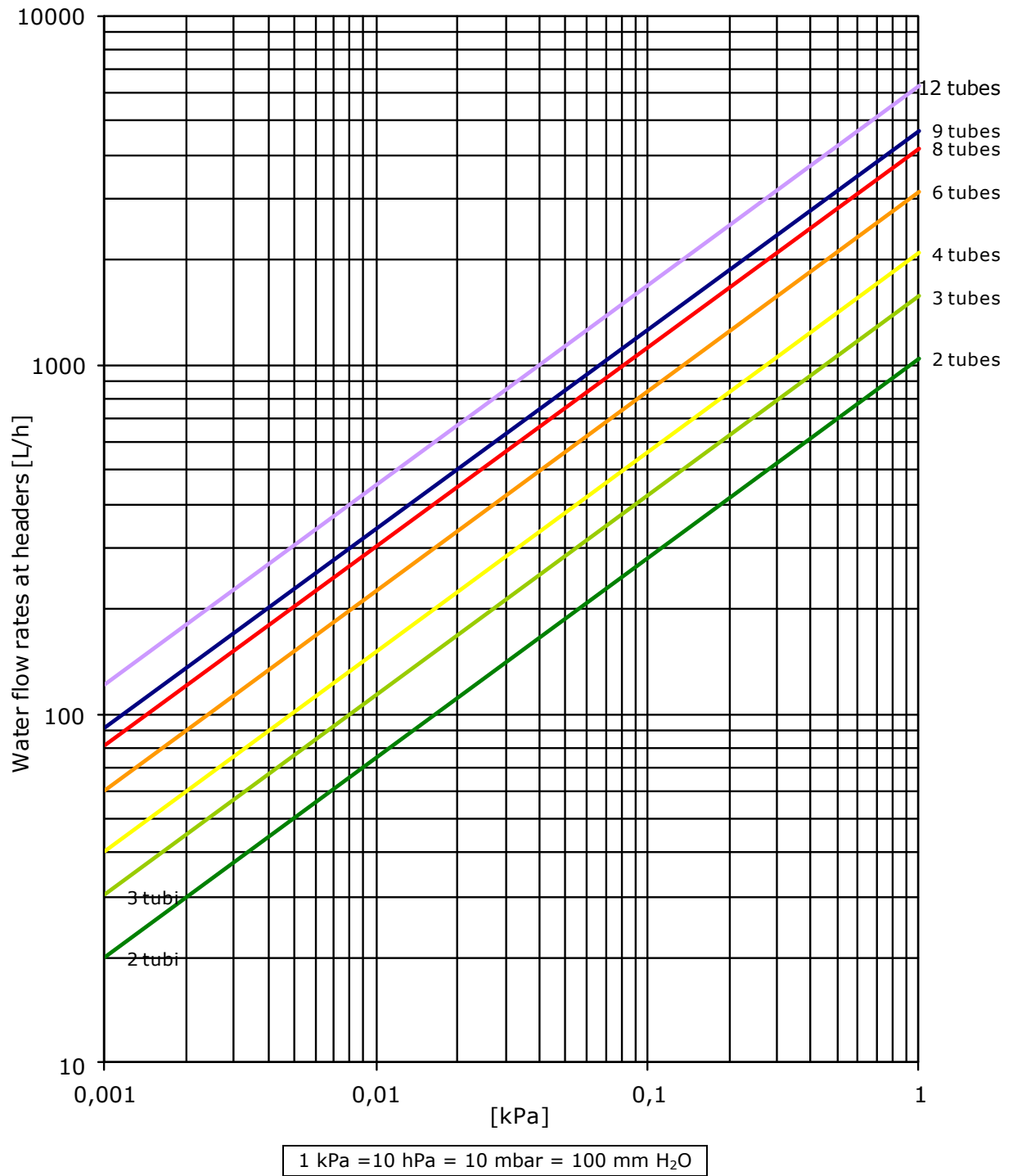
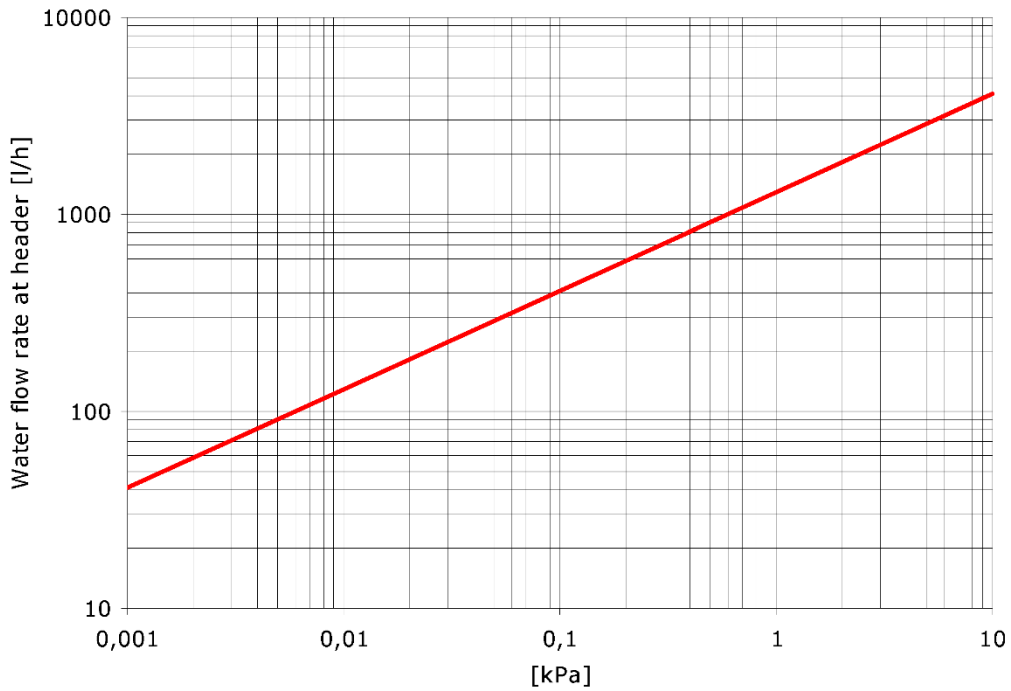


Fig. 1.25 Pressure drops per linear meter of radiant panel with 1.2 mm thickness tube and diaphragmed header (average temperature 80°C)



1 kPa = 10 hPa = 10 mbar = 100 mm H<sub>2</sub>O

Fig. 1.26 Average pressure drops per pair of header (average temperature 80°C)

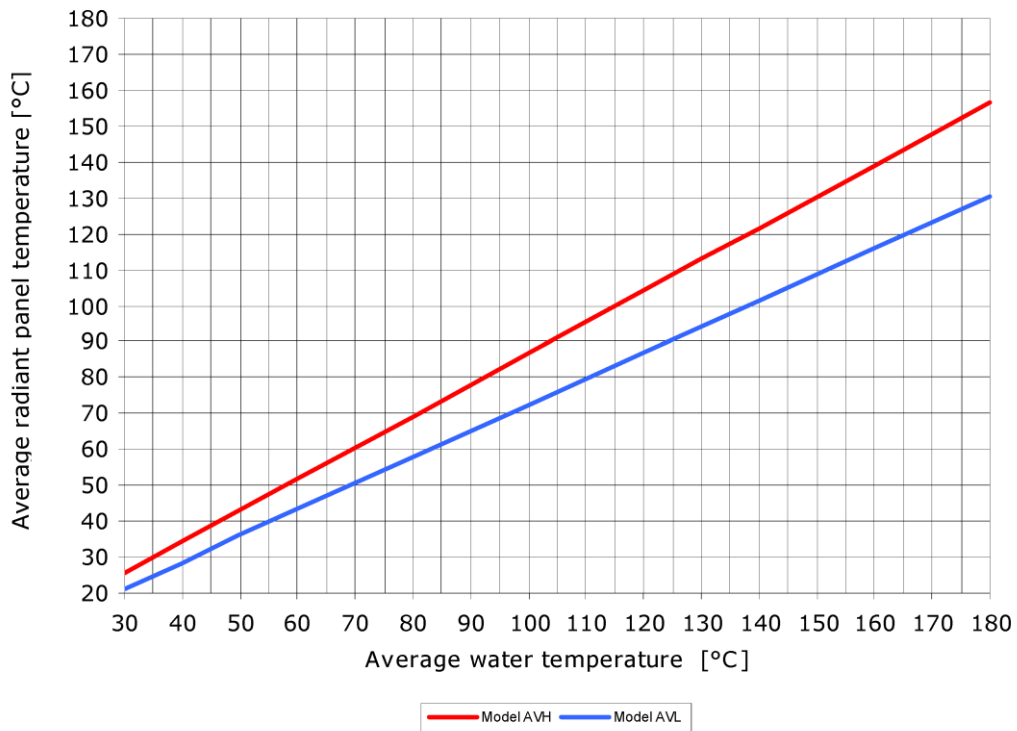


Fig. 1.27 Average surface temperature of the ceiling radiant panel

## 2 DESIGN

This is a description of the procedure recommended by CARLIEUKLIMA for carrying out proper design of a EUTERM ceiling radiant panel system.

### 2.1 Calculation of dispersion

The first step in designing a EUTERM ceiling radiant panel system is the determination of the thermal power required to heat the room under consideration. It is possible to use the CARLIEUKLIMA simplified dimensioning method (illustrated in chapter 4.3 of the CARLIEUKLIMA Design Manual).

To perform the calculation, the designer must choose the installation height for the EUTERM ceiling radiant panels, taking in consideration that heights greater than five meters involve great energy consumption due to the increase of radiated area. It is advisable to install the ceiling radiant panels as low as possible, compatible with the limits imposed by the temperature of the heating fluid and by the characteristics of the room (presence of bridge cranes, scaffolding, and so on).

### 2.2 Determination of the supply temperature and of the temperature drop of the strip heaters

Given the delivery temperature of the heating fluid, the design temperature drop  $\Delta T_{CP}$  is established between the inlet and the outlet of the radiant panel. The temperature drop values normally used vary, for hot water, from 5 to 20°C.

$$\Delta T_{CP} = T_I - T_{UP} \quad [^{\circ}\text{C}]$$

where:

$$T_I = \text{delivery temperature of the heating fluid} \quad [^{\circ}\text{C}]$$

$$T_{UP} = \text{temperature of the heating fluid when leaving the system} \quad [^{\circ}\text{C}]$$

$T_{UP}$  is thus determined:

$$T_{UP} = T_I - \Delta T_{CP} \quad [^{\circ}\text{C}]$$

It is possible to calculate the average design temperature  $T_{MP}$  of the thermal fluid:

$$T_{MP} = \frac{(T_I + T_{UP})}{2} \quad [^{\circ}\text{C}]$$

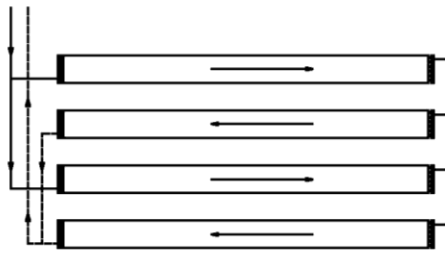
It is then possible to calculate the difference  $\Delta T_{TP}$  between the average fluid temperature  $\Delta T_{MP}$  and the ambient temperature  $T_O$ :

$$\Delta T_{TP} = T_{MP} - T_O \quad [^{\circ}\text{C}]$$

where:

$$T_O = \text{Operative ambient temperature} \quad [^{\circ}\text{C}]$$

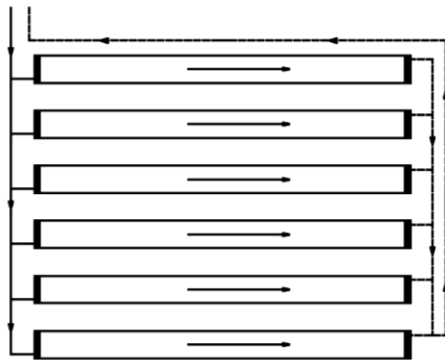
## 2.3 Choice of circuit type



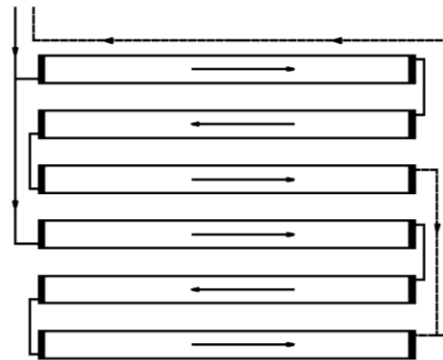
Inlet and outlet on same side - 2 panels in sequence



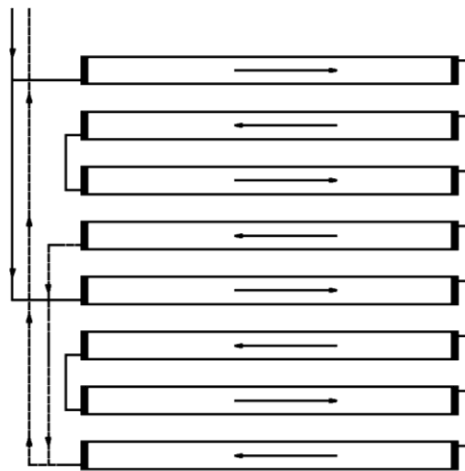
Inlet and outlet on same side - 4 panels in sequence



Inlet and outlet on opposite sides - 1panel

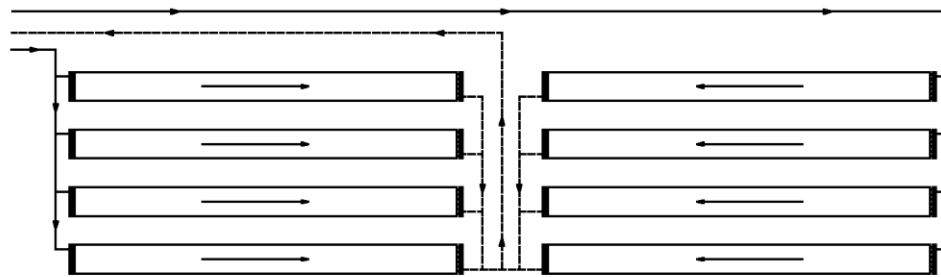


Inlet and outlet on opposite sides - 3 panels in sequence

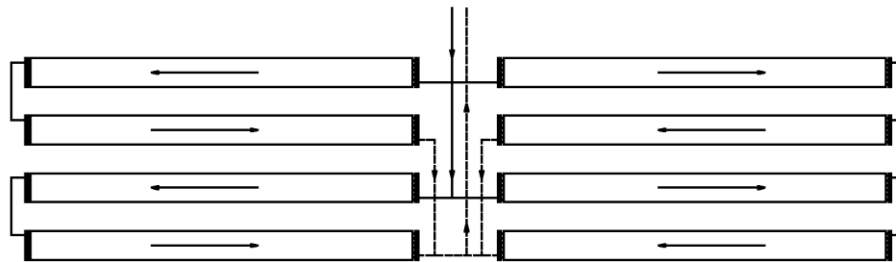


Inlet and outlet on same side - 4 panels in sequence

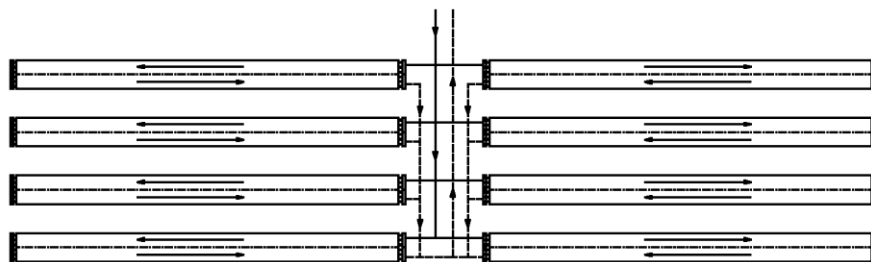
*Fig. 2.1 Examples of compensated type circuits*



Inlet and outlet on opposite sides - 1panel



Inlet and outlet on same side - 2 panels in sequence



Inlet and outlet on same side and same panel

*Fig. 2.2 Examples of compensated type circuits*

When choosing the type of circuit and the system layout, the following points need to be considered:

- the hydraulic circuit must be as well-balanced as possible; this will avoid installation of, and balancing by means of, valves and/or holders;
- when placing panels, it is necessary to consider the path between their supply (sometimes the supply circuits cost more than the ceiling radiant panels);
- for reasons of transversal temperature uniformity of the panel, it is advisable to use diaphragmed headers only when absolutely necessary.

## 2.4 Determination of the length of the radiant lines

The length of the radiant lines  $L$  [m] is established while keeping in mind that a radiant panel measures, minimum, two meters, and that it is better not to go over 40 meters totally, in order to avoid excessive pressure drops and non-uniform temperatures.

## 2.5 Choice of model of ceiling mounted radiant panel and determination of number of radiant lines

To determine the number of radiant lines, it is necessary to choose the model of radiant panel to be used. It is advisable to choose, as a first attempt, the model with the greatest number of tubes (model H) and the greatest possible width, compatible with the limitations imposed by the installation height. Table 2.1 shows the minimum installation heights which must be adhered to, based on the radiant panel model and on the fluid temperature.

	EUTERM AVH				EUTERM AVL			
Average water temperature [°C]	Radiant panel width [mm]							
	300	600	900	1200	300	600	900	1200
Tmp	Minimum installation height [m]							
<b>60</b>	2.9	3.0	3.0	3.0	2.8	2.9	2.9	2.9
<b>70</b>	3.1	3.2	3.2	3.3	3.0	3.1	3.1	3.1
<b>80</b>	3.2	3.4	3.5	3.5	3.1	3.2	3.4	3.4
<b>90</b>	3.4	3.6	3.7	3.8	3.3	3.4	3.6	3.6
<b>100</b>	3.6	3.7	4.0	4.0	3.5	3.6	3.8	3.9
<b>110</b>	3.8	3.9	4.2	4.3	3.7	3.8	4.0	4.1
<b>120</b>	3.9	4.1	4.5	4.5	3.8	3.9	4.3	4.4
<b>130</b>	4.1	4.3	4.7	4.8	4.0	4.1	4.5	4.6

Tab. 2.1 Minimum recommended installation height (in meters from the floor)

From tables 1.4 e 1.5, for the selected model one obtains the thermal output value  $R_T$  [W/m] of the radiant panel, for the temperature difference  $\Delta T$  which is nearest to the temperature difference  $\Delta T_p$  that was previously calculated.

With this value, by means of the following formula, it is possible to determine the number of radiant lines needed to meet the thermal requirements of the building.

$$N = \frac{\Phi}{L \cdot R_T}$$

where:

N =	number of radiant lines	
$\Phi$ =	thermal power required, calculated in point 2.1	[W]
L =	length of radiant lines	[m]
$R_T$ =	thermal output of radiant panel per meter	[W/m]

## 2.6 Verification of interval between strip heaters

To ensure good heat uniformity in a given area of the building, the panels must not be too far from one another.

The maximum interval between panels is determined based on the installation height and the height of the work surface (figure 2.3), using the following formula:

$$I_{MAX} = 1,5 (H-h) \quad [m]$$

where:

$I_{MAX}$ =	distance between the centerlines of two adjacent ceiling radiant panels	[m]
H =	installation height	[m]
h =	height of work surface	[m]

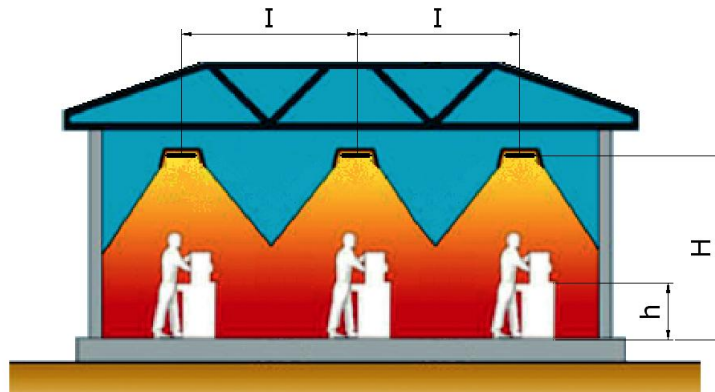


Fig. 2.3 Installation height of the ceiling radiant panels

Table 2.2 shows the maximum interval values for a work surface height of 1.5 meters.

H [m]	3.5	4.0	4.5	5.0	5.5	6.0	7.0	8.0	9.0	10.0	11.0	12.0	13.0	14.0	15.0
I* [m]	3.0	3.8	4.5	5.3	6.0	6.8	8.3	9.8	11.3	12.8	14.3	15.8	17.3	18.8	20.3

Tab.

Maximum interval between panels in relation to installation height

2.2.

\* With work surface height of 1.5 m.

The values which can be obtained from the formula and from the previous table must be reduced when the radiant panel is installed near a perimeter wall. This reduction varies from 10% to 50%, depending on the characteristics of the room (average transmittance of the walls).

The design interval  $I_p$  is then calculated by means of the following formula:

$$I_p = \frac{L_1}{(N^* + 1)} \quad [m]$$

Where:

$I_p$  = design interval between panels [m]

$N^*$  = number of longitudinal axes of the ceiling radiant panels

$L_1$  = length of the wall perpendicular to the longitudinal axes of the strip heater [m]

The example in Figure 2.4 shows the wall  $L_1$  and the 6 longitudinal axes  $N^*$  of the ceiling radiant panels (shown in red).

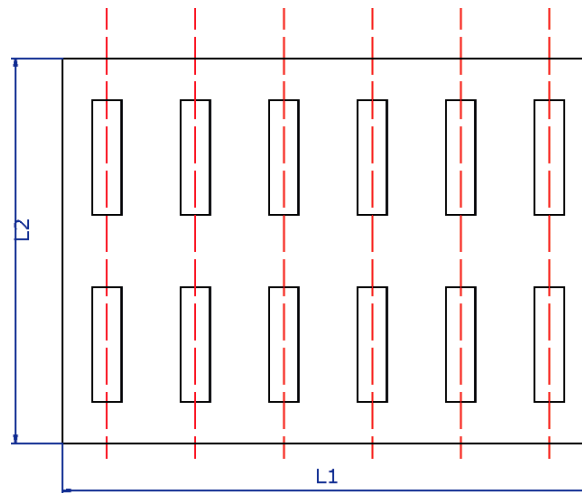


Fig. 2.4 Building with longitudinal axes of the ceiling radiant panels highlighted

At this point in dimensioning, two things may occur:

- the design interval  $I_p$  is less than the value of the maximum interval  $I_{MAX}$ . This means that the choices made are correct and it is possible to proceed with the system dimensioning;
- the design interval  $I_p$  is greater than the value of the maximum interval  $I_{MAX}$ . In this case it is necessary to go back to point 2.5 of dimensioning and change the previously selected radiant panel model, choosing a model with a lower thermal output (with a lesser number of tubes or with a lesser width of the panels). Proceed by trial and error until the design interval  $I_p$  results less than the maximum interval  $I_{MAX}$ , then proceed with the subsequent dimensioning steps.

## 2.7 Calculation of actual temperature drop and average temperature

If, for the chosen model of radiant panel, the temperature drop  $\Delta T_{table}$  obtained from tables 1.5 and 1.7 is different from the designed temperature drop  $\Delta T_p$ , calculate the actual temperature drop  $\Delta T$  and the actual average temperature of the fluid  $T_M$  with the following formulas:

$$\Delta T = T_I - T_U = 2 (T_I - \Delta T_{table} - T_O) \quad [^{\circ}\text{C}]$$

where:

$$T_U = \text{actual temperature of heating fluid exiting the system} \quad [^{\circ}\text{C}]$$

It is also possible to calculate the actual average temperature of the thermal fluid.

$$T_M = \Delta T_{table} + T_O \quad [^{\circ}\text{C}]$$

## 2.8 Calculation of water flow rate and pressure drops

The total water flow rate  $P$  required by the system is calculated by means of the following formula:

$$P = \frac{\Phi}{1,163 \cdot (T_I - T_{UE})} \quad [\text{L/h}]$$

(For the sake of simplicity, it is assumed that the density of the water is  $1 \text{ kg/dm}^3$  and the specific heat of the water is  $4.186 \text{ kJ/(kg K)}$ ).

where:

$\Phi$  = thermal power required, calculated in point 2.1 [W]

$T_I$  = delivery temperature of the heating fluid [°C]

$T_U$  = actual temperature of the heating fluid when leaving the system [°C]

The flow rate of each radiant line  $P_L$  is:

$$P_L = \frac{P}{N_S} \quad [\text{L/h}]$$

where:

$N_S$  = the number of circuits composed of one or more radiant lines (ceiling radiant panels) in series.

The flow rate of the single tube is:

$$P_{TUBE} = \frac{P_L}{N_{TP}} \quad [\text{L/h}]$$

where:

$N_{TP}$  = the number of tubes per panel

the value must fall into those suggested in paragraph 1.4.

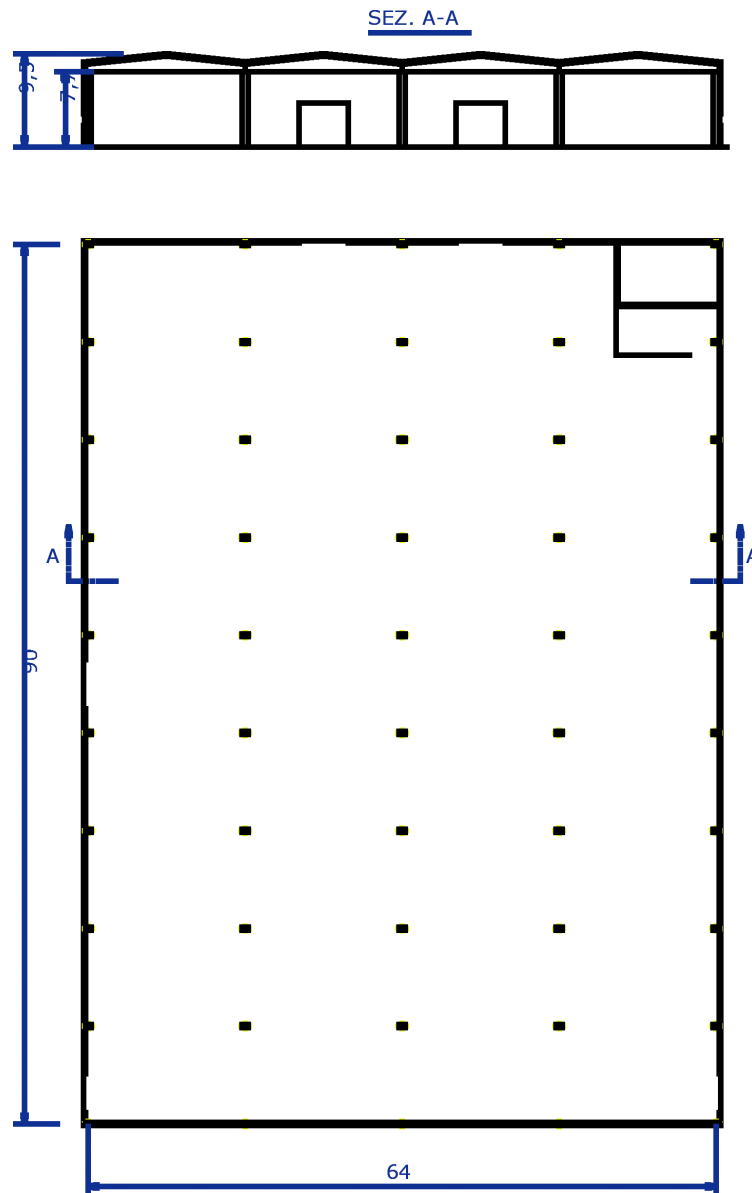
From the flow rate values of the single radiant panel, of each header and of the sections of the supply circuit, using the diagrams in Figures 1.24, 1.25, 1.26, 1.27, 1.28, calculate the pressure drops in the entire circuit and dimension the relative circulator.

## 2.9 Example of design

Consider the dimensioning of the radiant system for the industrial warehouse shown in Figure 2.5.

Size of building:

Length: 90 m  
Width: 64 m  
Total height: 9,5 m



*Fig. 2.5 Industrial warehouse to be heated with EUTERM system*

### 2.9.1 Calculation of thermal requirement

The total thermal dispersion was calculated with the CARLIEUKLIMA simplified method. For an installation height of 7.7 meters and an ambient operative temperature  $T_o$  18°C the thermal requirement  $\Phi$  is 876 KW.

### 2.9.2 Determination of the supply temperature and of the temperature drop of the ceiling radiant panels

Given a water delivery temperature  $T_I$  84°C a temperature drop  $\Delta T_{CP}$  is established of 12.5°C and the outlet temperature of the water from the system  $T_U$  and the average design  $T_{MP}$  are determined.

$$\Delta T_{CP} = T_I - T_{UP} = 12,5^{\circ}\text{C};$$

$$T_{UP} = T_I - \Delta T_{CP} = 84 - 12,5 = 71,5^{\circ}\text{C};$$

$$T_{MP} = \frac{(T_I + T_{UP})}{2} = 77,75^{\circ}\text{C};$$

$$\Delta T_P = T_{MP} - T_O = 77,75 - 18 = 59,75^{\circ}\text{C}$$

### 2.9.3 Choice of circuit type

Choose the type of circuit indicated in Figure 2.6, using pairs of ceiling radiant panels in series. With this supply scheme, standard type headers are used.

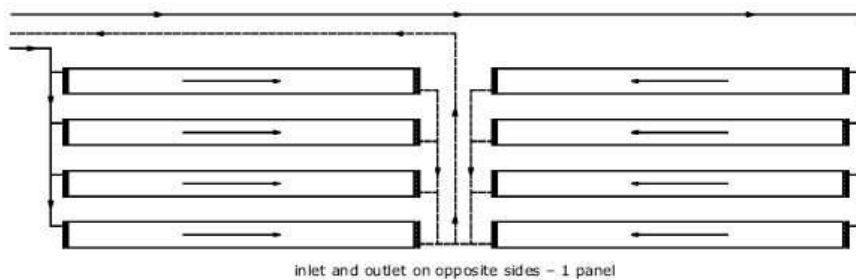


Fig. 2.6 Diagram of the type of circuit selected

### 2.9.4 Determination of the length of the lines of ceiling mounted ceiling radiant panels

Each single line of ceiling radiant panels has a length of 30 meters (it is composed of five ceiling radiant panels of six meters each). Leave enough room ahead of the ceiling radiant panels for all of the technological equipment.

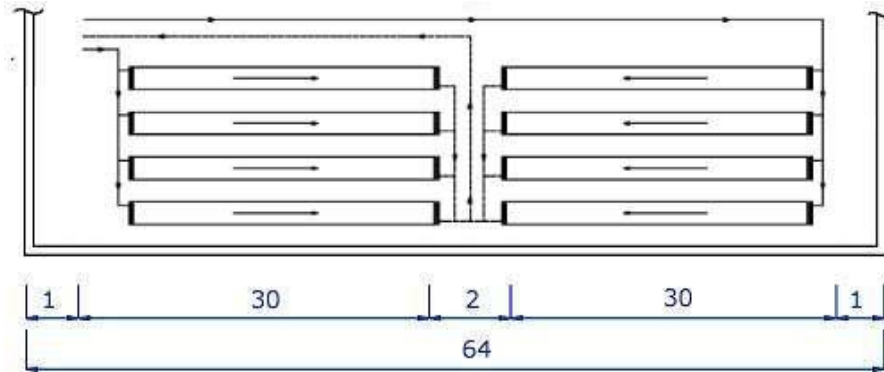


Fig. 2.7 Length of radiant lines

### 2.9.5 Choice of model of ceiling mounted radiant panel and determination of number of radiant lines

As a first attempt, choose the EUTERM AVH 900 model of ceiling radiant panel. Use table 1.3 to determine the thermal output for the thermal difference considered:

$$\Delta T_p = 59,75^\circ\text{C}$$

$$R_T = 576 \text{ W/m}$$

It is thus possible to calculate the number of radiant lines  $N$ :  $N = \frac{\Phi}{L \cdot R_T} = 50,69$

Figure 2.8 shows the warehouse with the layout of the radiant lines.

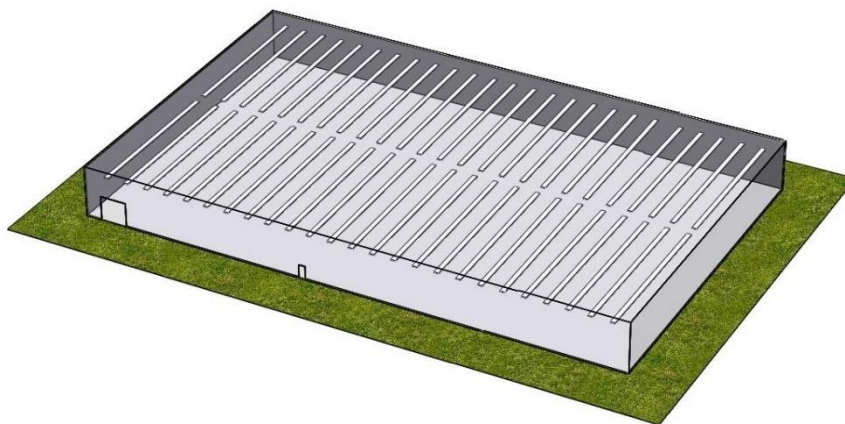


Fig. 2.8 Layout of the radiant lines in the warehouse

We will install no. 50 radiant lines, 30 m long. In this way, the real yield per m will be 584 W.

## 2.9.6 Verification of interval between ceiling mounted radiant panels

The maximum interval between ceiling radiant panels is:

$$I_{MAX} = 1,5 (H-h) = 1,5 (7,7 - 1,5) = 9,3 \text{ m}$$

Where:

H = 7,7 m (installation height)

h = 1,5 m (height of work surface)

Then calculate the design interval  $I_p$ :

$$I_p = \frac{L_1}{(N^* + 1)} = \frac{90}{(25 + 1)} = 3,46\text{m}$$

Where:

$N^*$  = 25 (number of longitudinal axes of the radiant panels)

$L_1$  = 90 m (length of the wall perpendicular to the longitudinal axes of the radiant panel)

The design interval is less than the maximum, so the dimensioning is acceptable.

$$I_p < I_{MAX} = 3,46\text{m} < 9,3\text{m}$$

## 2.9.7 Calculation of actual temperature drop and average temperature

For the chosen model of radiant panel, the temperature drop  $\Delta T_{table}$  obtained from table 1.3, is similar to the design temperature drop  $\Delta T_p$ . The previously calculated temperatures are the actual ones. Otherwise ( $\Delta T_p$  is very different to  $\Delta T_{table}$ ) calculate the temperature drop from the formula indicated at point 2.7.

### Example:

Calculate the effective  $\Delta T$  from the table 1-3

$$\Delta T_p = 59,75^\circ\text{C}$$

$$\Delta T_{table} = 61^\circ\text{C}$$

Using the formula indicated on point 2.7, we will calculate the real temperature fall.

$$\Delta T_E = T_I - T_{UE} = 2 (T_I - \Delta T_{table} - T_O) = 10,0^\circ\text{C}$$

$$T_{UE} = T_I - \Delta T_E = 74^\circ\text{C}$$

As we can see, when  $\Delta T_p$  is similar to  $\Delta T_{table}$ , also the outgoing effective temperature is not so different from the project temperature

$$T_{UE} = 74^\circ\text{C} / T_{UP} = 71,5^\circ\text{C} \text{ (see point 2.9.2)}$$

## 2.9.8 Calculation of water flow rate and pressure drops

The total water flow rate P required by the system is calculated is the following:

$$P = \frac{\Phi}{1,163 \cdot (T_I - T_U)} = \frac{876000}{1,163 \cdot (84 - 74)} = 75322 \quad [\text{L/h}]$$

(For the sake of simplicity, it is assumed that the density of the water is  $1 \text{ kg/dm}^3$  and the specific heat of the water is  $4.186 \text{ kJ/(kg K)}$  ).

where:

$\Phi$ = required thermal power	[W]
$T_I$ = delivery temperature of the heating fluid	[°C]
$T_U$ = actual temperature of the heating fluid when leaving the system	[°C]

The flow rate of each radiant line  $P_L$  is:

$$P_L = \frac{P}{N_S} = \frac{75322}{50} = 1506 \quad [\text{L/h}]$$

where:

$N_S$  = the number of circuits composed of one or more radiant lines (ceiling radiant panels) in series.

This value must always be bigger or equal than the one suggested on paragraph 1.6 and, in this case, is acceptable (minimum required 469 [L/h]).

The flow rate of the single tube is:

$$P_{\text{TUBE}} = \frac{P_L}{N_{\text{TP}}} = \frac{1506}{9} = 167,4 \quad [\text{L/h}]$$

where:

$N_{\text{TP}}$  = the number of tubes per panel

From the flow rate values of the single radiant panel, of each header, of the sections of the supply circuit, using the diagrams in Figures 1.24, 1.25, 1.26, 1.27, 1.28, calculate the pressure drops of the entire circuit and dimension the relative circulator.

Ceiling radiant panel with 9 tubes, water flow at header 1506 [l/h]

Pressure drop/meter = 0.03 kPa = 0.3 mbar = 3 mm H<sub>2</sub>O. (fig. 1.24)

Pressure drop for radiant panel length 30 m = 0.9 kPa = 9 mbar = 90 mm H<sub>2</sub>O

Pressure drop for couple of headers (standard) = 1.5 kPa = 15 mbar = 150 mm H<sub>2</sub>O (fig. 1.28).

Total pressure drop for radiant panel (not included the electrical main) = 2.4 kPa = 24 mbar = 240 mm H<sub>2</sub>O (couple of headers +30 m of radiant panel).

## 3 INSTALLATION

The EUTERM radiant panels are supplied with the following accessories: headers, insulating mat, side profiles, fiberglass-holding straps and junction covers. The installation of the EUTERM ceiling radiant panels is fast and easy. It is possible to assemble the radiant system on the ground and then lift more panels connected together, being careful of their alignment until they reach the installation height planned.

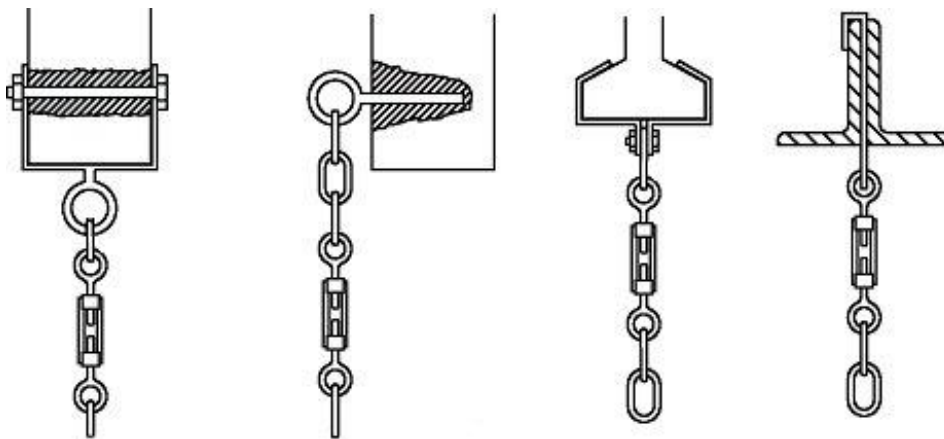


**ATTENTION:**

**Before installing the system, it is necessary to remove the protecting film on the surface of the radiant panel!**

### 3.1 Suspension brackets

The EUTERM ceiling radiant panels are equipped with angular with holes, to be connected with anchors for the fastening to the building. The fastening of the anchors (chains, steel cable or rod) to the building structure must be performed with expansion screws, profiles or braces, in such a way that the safety in the installation is guaranteed. All of the suspensions must be equipped with adjustment systems such as right hand/left hand tie rods or other screw adjustments for adjusting the panel. The first phase of installation consists of fastening the support anchors in the positions set forth in the design.



*Fig. 3.1 Types of fastening of anchors to the building structure*

### 3.1.1 Width of brackets

Table 3.1, figure 3.2 shows the recommended distances for fastening the anchors based on the width of the EUTERM radiant panel.

Radiant panel width [mm]	300	600	900	1200
Recommended distance between brackets [mm]	220	520	820	680

Tab. 3.1 Recommended distance [mm] between brackets when changing width of radiant panel

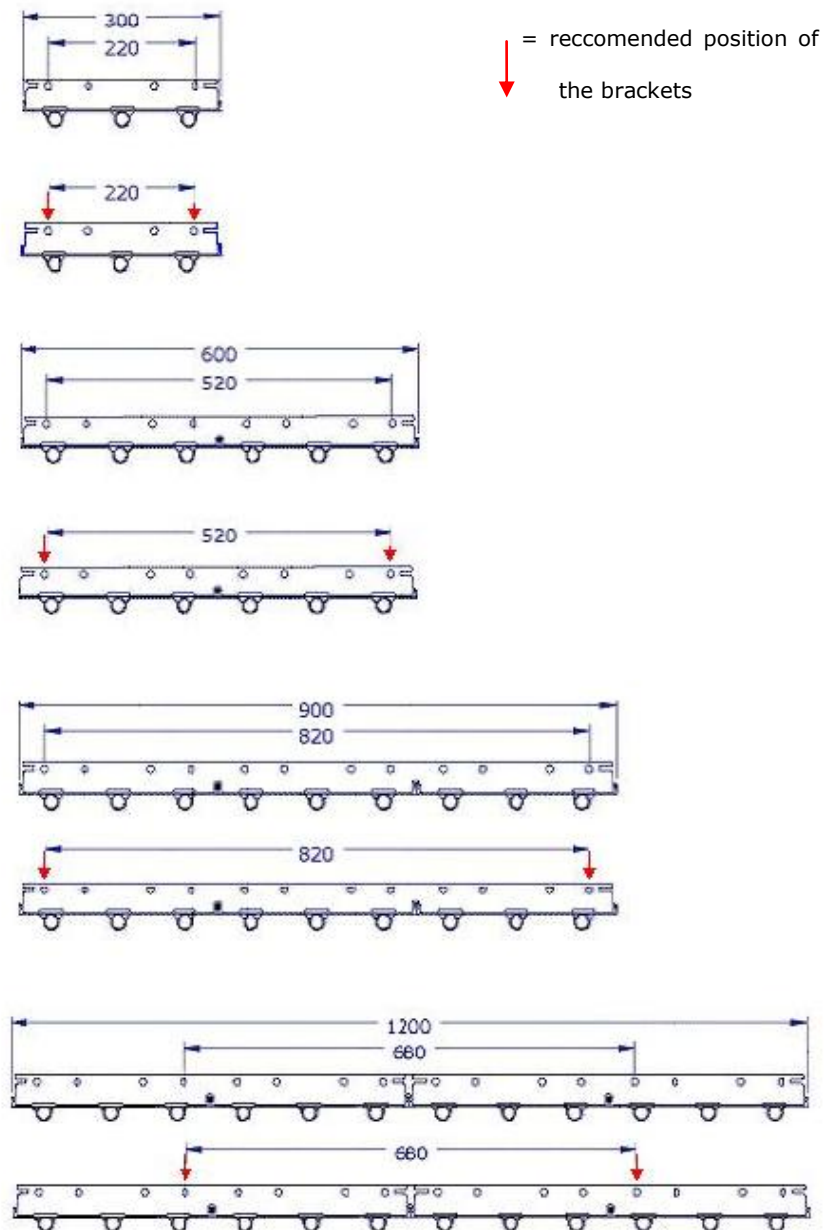


Fig. 3.2 Recommended distance [mm] between brackets when changing width of radiant panel

### 3.1.2 Distance between brackets

Figure 3.3 shows the positions of the corner pieces as the length of the radiant panel is changed. The corner pieces contain holes with a diameter of 10 mm which are connected to the anchors by bolts. The tie rods must always be connected close to the headers and have a distance not bigger than 2 meters one from the other. Only in the case of radiant panels joined together, the distance between the rods can reach 2.35 m.

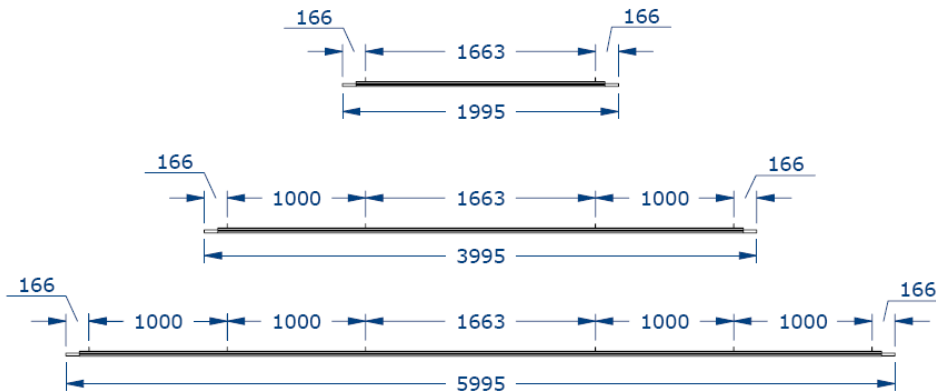


Fig. 3.3 Interval between corner pieces as length of heater strips is varied [mm]

### 3.1.3 Number of anchors

It is advisable to carry out installation using two anchors, as shown in Figure 3.4; as an alternative, connection to the building structure can be performed with a single anchor, as shown in figure 3.5. In this case the angle that the anchors form with the radiant panel (angle  $\alpha$  shown in Figure 3.5) must be greater than  $60^\circ$ .

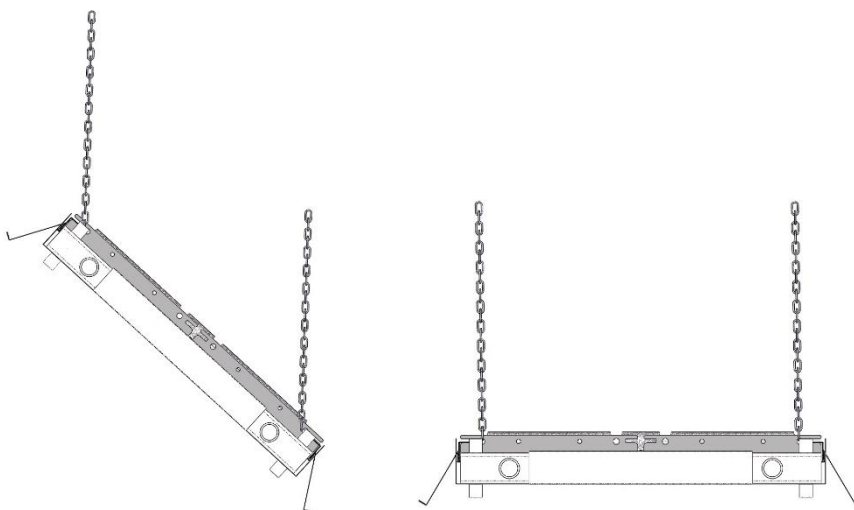


Fig. 3.4 Installation of strip heaters with two anchors

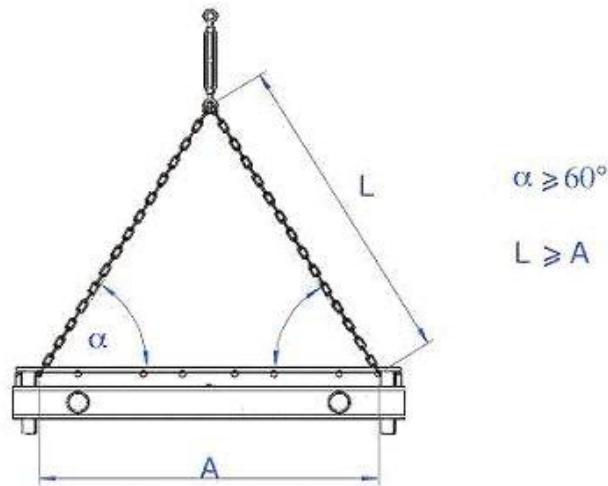


Fig. 3.5 Installation of radiant panel with one anchor

### 3.1.4 Length of anchors

The radiant panels, depending on the temperature of the fluid and their length, are subject to lengthening which must be absorbed by the anchors. The following table shows the minimum length of the anchors as the average temperature of the fluid changes.

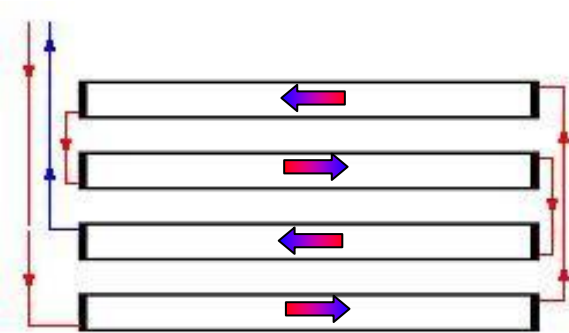
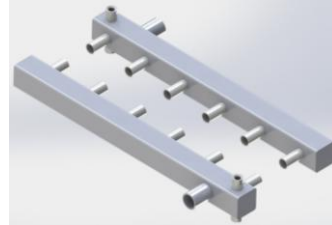
Length of radiant panel [m]	Average heating fluid temperature [°C]					
	45	60	80	100	120	140
Length of anchors [cm]						
18	15	18	22	28	34	41
24	17	21	26	33	40	48
30	20	25	31	39	47	56
36	24	30	37	46	55	65
42	29	36	44	54	64	75

Tab. 3.2 Minimum length of anchors [cm] as heating fluid temperature changes

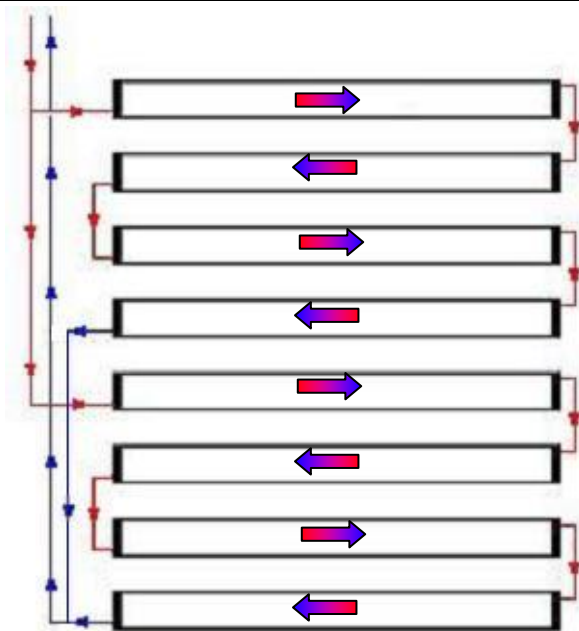
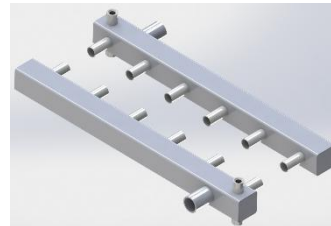
### 3.2 Types of circuits and types of headers



Inlet and outlet on same side  
-  
2 panels  
Serial fed  
-  
With **STANDARD** headers



Inlet and outlet on same side  
-  
4 panels  
Serial fed  
-  
With **STANDARD** headers



Inlet and outlet on same side  
-  
4 panels  
Serial fed  
-  
With **STANDARD** headers

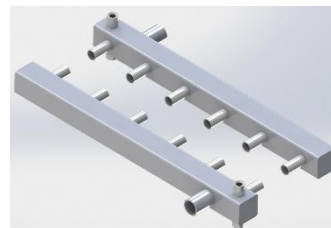
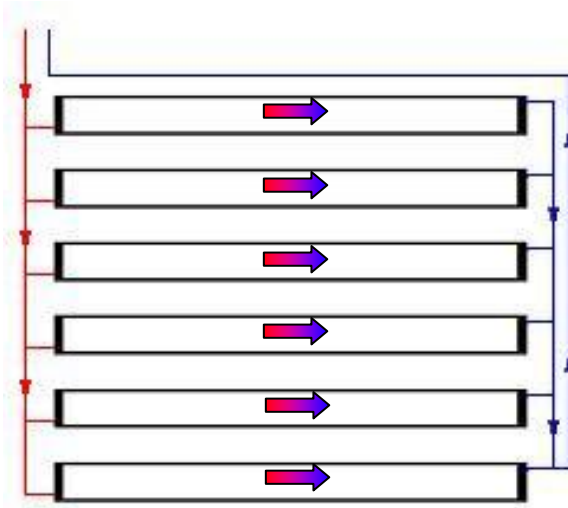
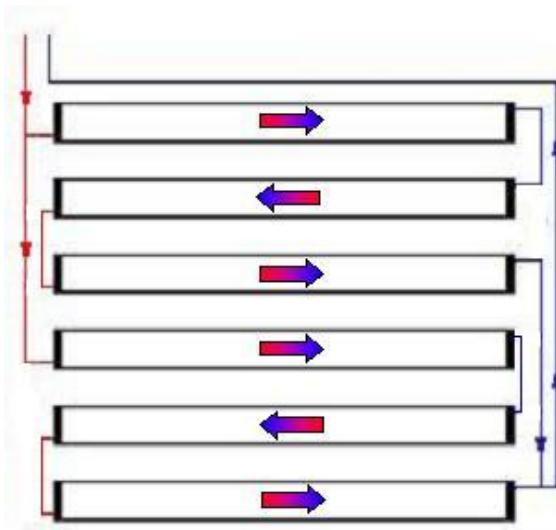
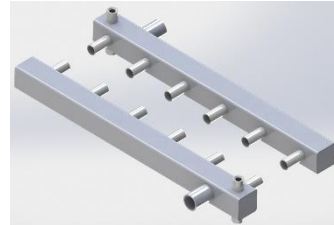


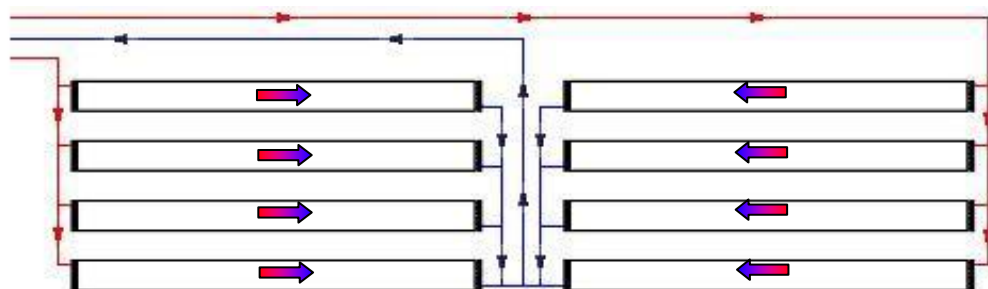
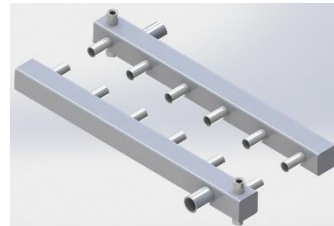
Fig. 3.6 Examples of compensated type circuits with STANDARD headers



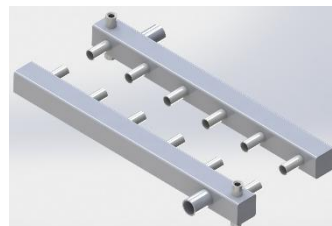
Inlet and outlet on opposite sides  
-  
1 panel  
Serial fed  
-  
With **STANDARD** headers



Inlet and outlet on opposite sides  
-  
3 panels  
Serial fed  
-  
With **STANDARD** headers



Inlet and outlet on opposite sides  
-  
1 panel  
Serial fed  
-  
With **STANDARD** headers



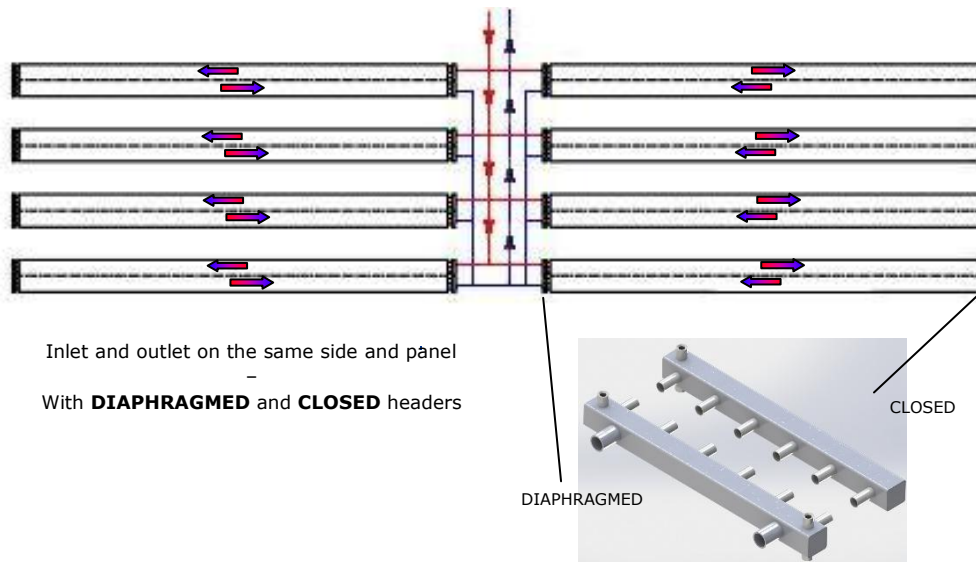
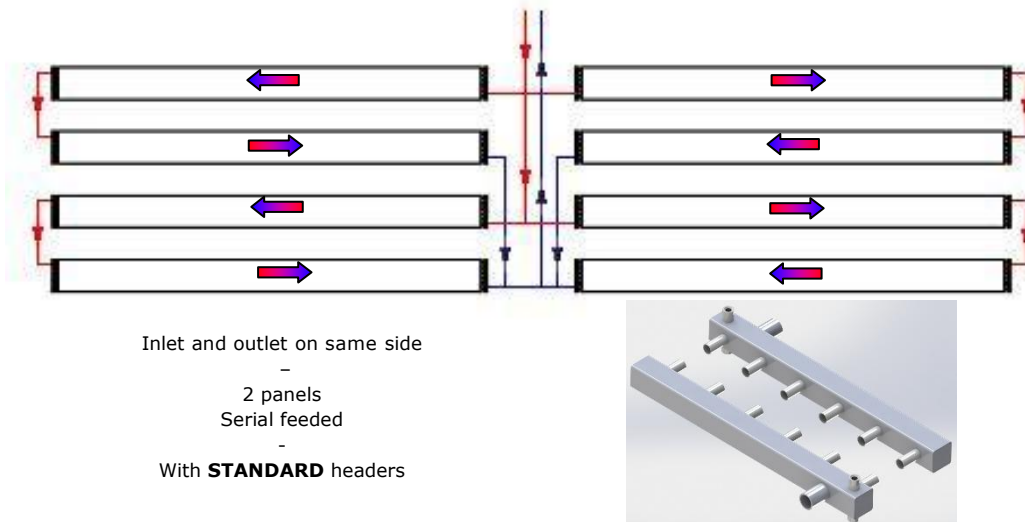


Fig. 3.7 Examples of compensated type circuits with DIAPHRAGMED and CLOSED headers

In the choice of type of circuit and system layout, it is necessary to pay attention to the following points:

- the hydraulic circuit must be balanced in the best way; this avoid the installation and the balancing through valves and/or holders;
- for the disposal of the panels, must be considered the supply net (sometimes the supply nets cost more than the ceiling radiant panels);
- for reasons of transversal temperature of the panel, it is recommended to use the diaphragmed headers only where really necessary.

### 3.3 Connection of headers

The connection of the headers to the tubes of the ceiling radiant panels is made with sleeves to press in carbon galvanized steel. These sleeves with bore, ext. diameter 22.0 mm, are equipped with o-rings in EPDM.

If the system will work with superheated water, it must be used special o-rings, suitable for the operation with steam, produced by firms which provide guarantees on the seals of the tubes.

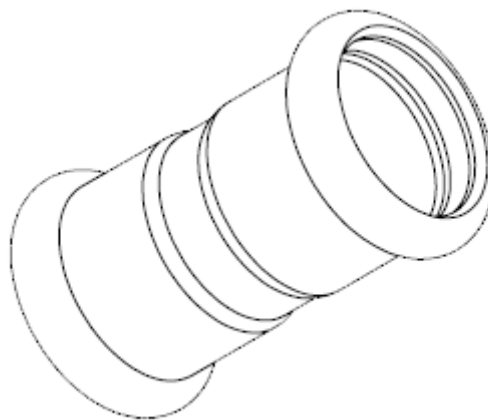
If the insertion of the tube on the sleeve is difficult, because of the restricted tolerance, **can be used lubricating like water or soap water.**



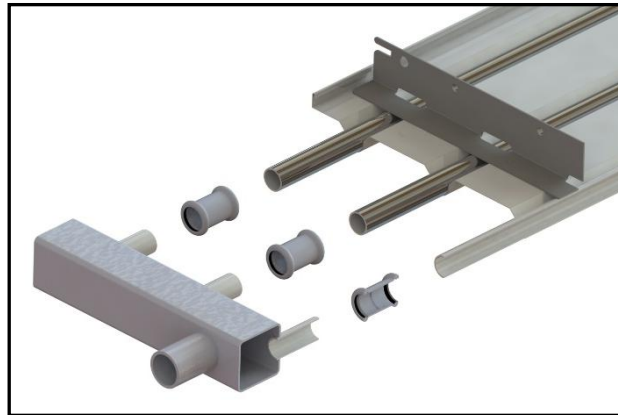
**ATTENTION:**

**Never use OILS, GREASES, SILICONE SPRAYS or any other LUBRICANT for this purpose!**

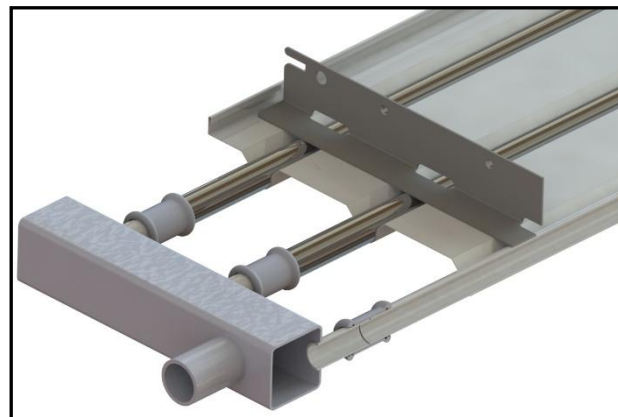
For a perfect connection, it is recommended to use sleeves with central beat, made for pipes with a 22.0 mm diameter. It is also recommended to use a pressing machine equipped with one-piece adjustable jaws, **"M" type** profile, compatible with the provided sleeves.



*Fig. 3.8 Example with used sleeve*



*Fig. 3.9 Connection between the header and the pipeline with sleeves to press*



*Fig. 3.9b Insert of the header*

Make the connection between the smooth cut pipes of the header and the pipes of the radiant panel using the proper sleeves, being careful to insert them till the beat.



Fig. 3.9c Pinch the sleeve with the suitable tool

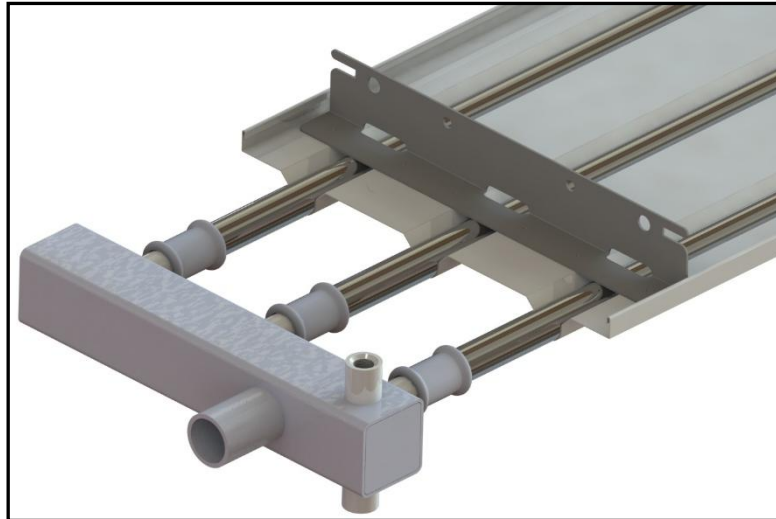


Fig. 3.9e Example of a header connected to the panel

### 3.4 Installation of header covers (accessory supplied on request)

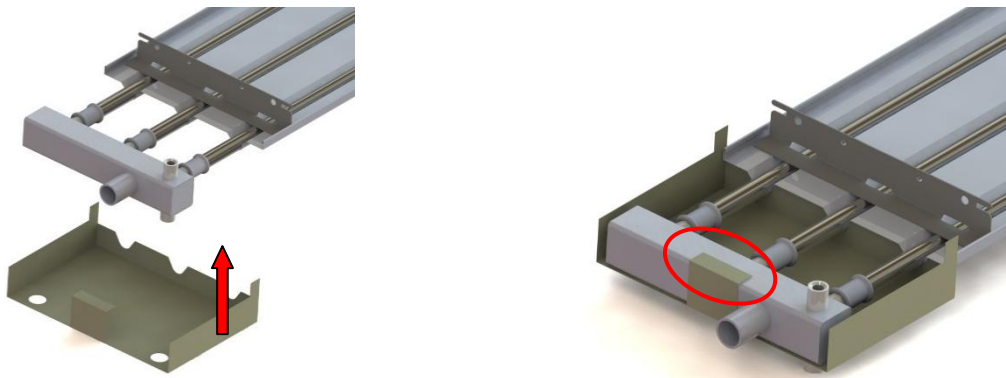


Fig. 3.10 Apply the header cover as shown in the picture below

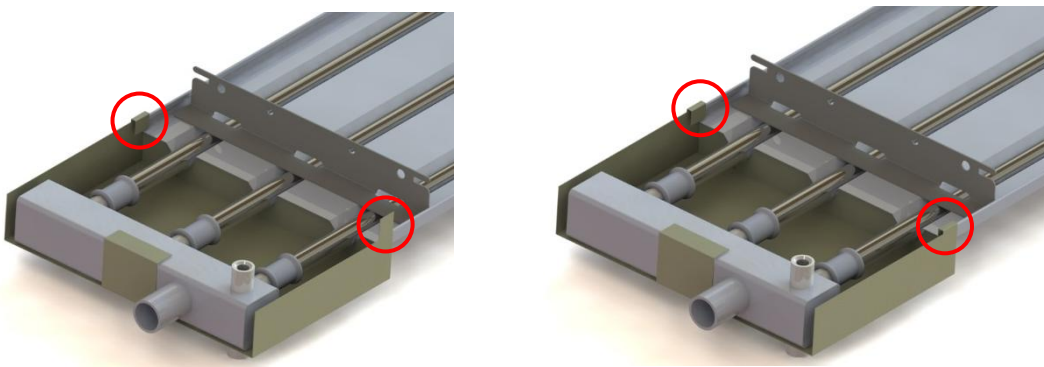


Fig.3.10a Fix the header cover to the panel, bending the special winglet

### 3.5 Lifting the ceiling radiant panels

The ceiling radiant panels are lifted and the anchors are hooked onto the special brackets on the frame. To vent air and discharge water, when placing the system at the desired height is advisable to tilt the radiant panel slightly, both along the transversal axis and along its longitudinal axis, as shown in Figures 3.11 and 3.12. It is important that the inlet point of the heating fluid, where the air vent valve is located, is positioned at the highest point of the system, and the outlet connection, where the water discharge is housed, is always at the lowest point.

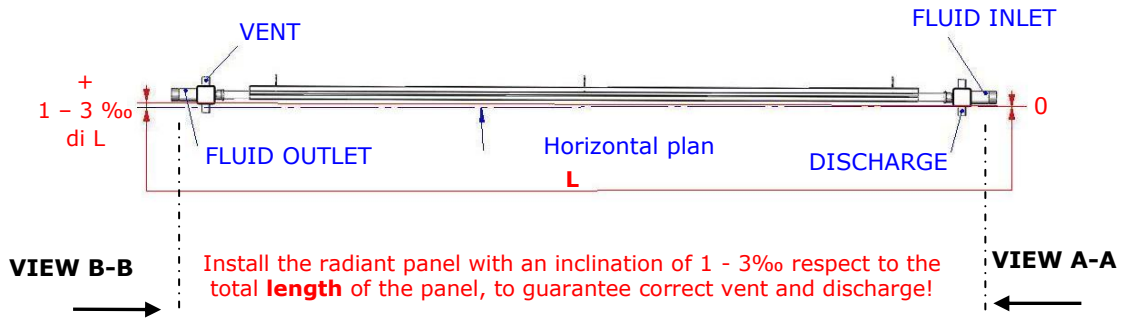


Fig. 3.11 Slight tilting of the radiant panel along the longitudinal plan

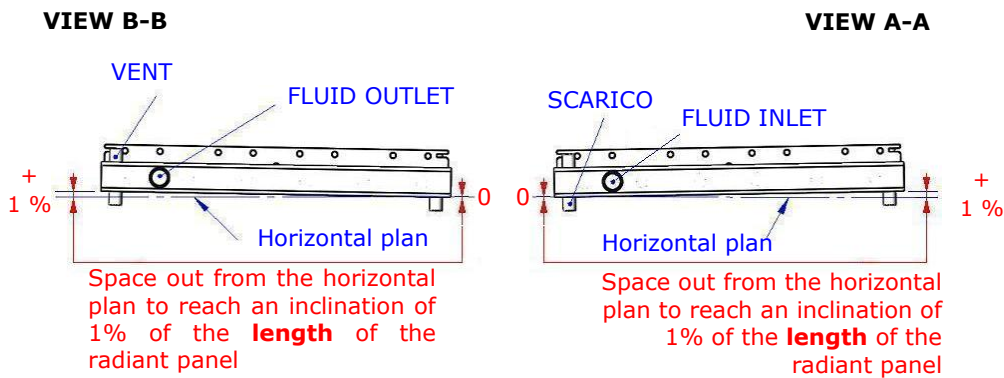
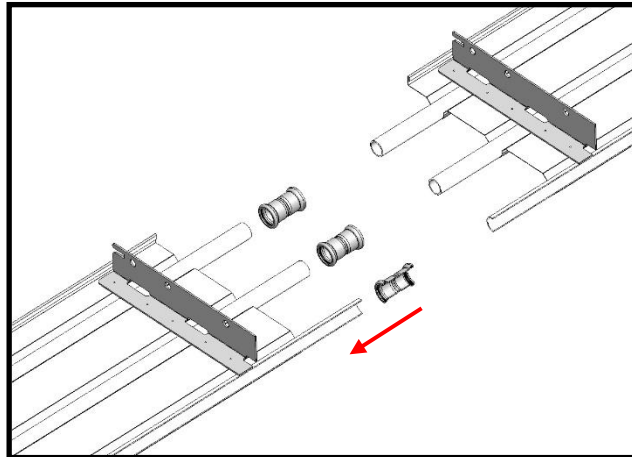


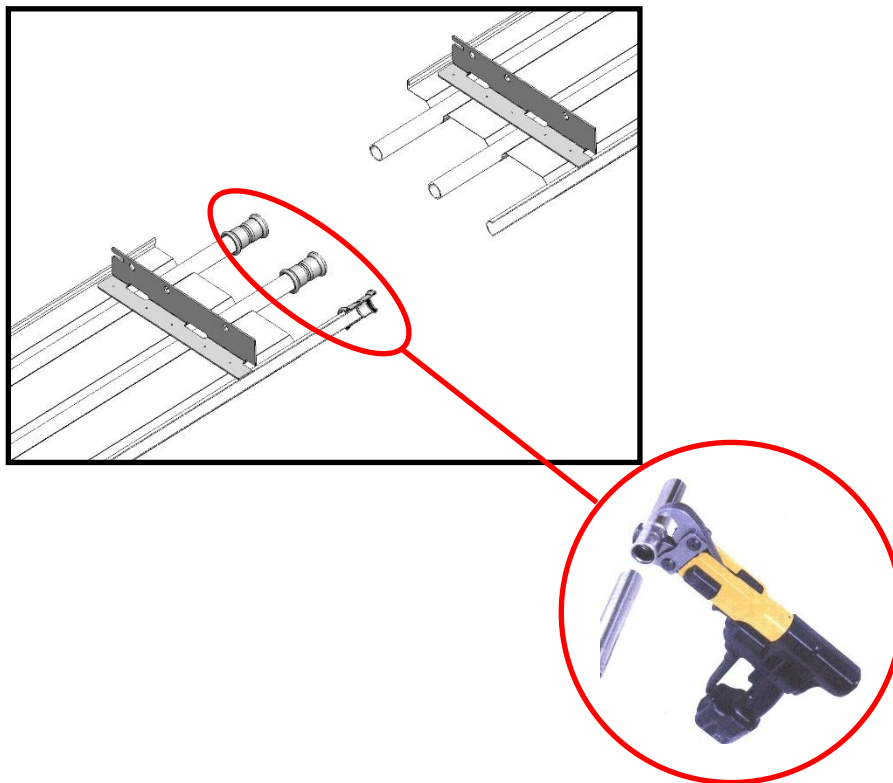
Fig. 3.12 Slight tilting of the radiant panel along the transversal plan

### 3.6 Connection between ceiling radiant panels

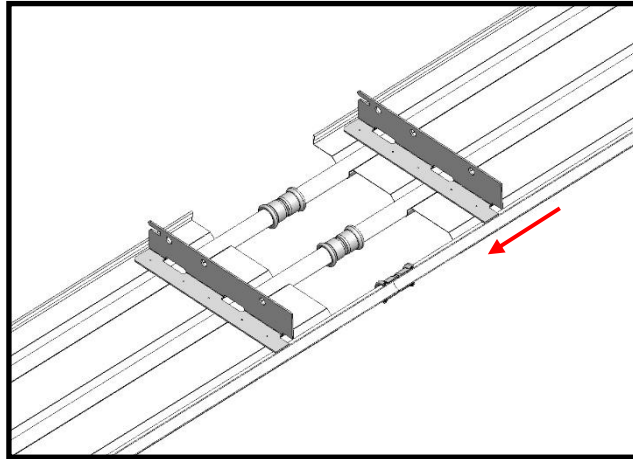
The connection between the tubes of the ceiling radiant panels is performed with galvanized carbon steel pincer-closed sleeves. It is necessary to use sleeves with a bore of an external diameter of 22 mm and special O-rings in EPDM (for superheated water systems use suitable O-rings), produced by firms which provide suitable guarantees on the seals of the tubes.



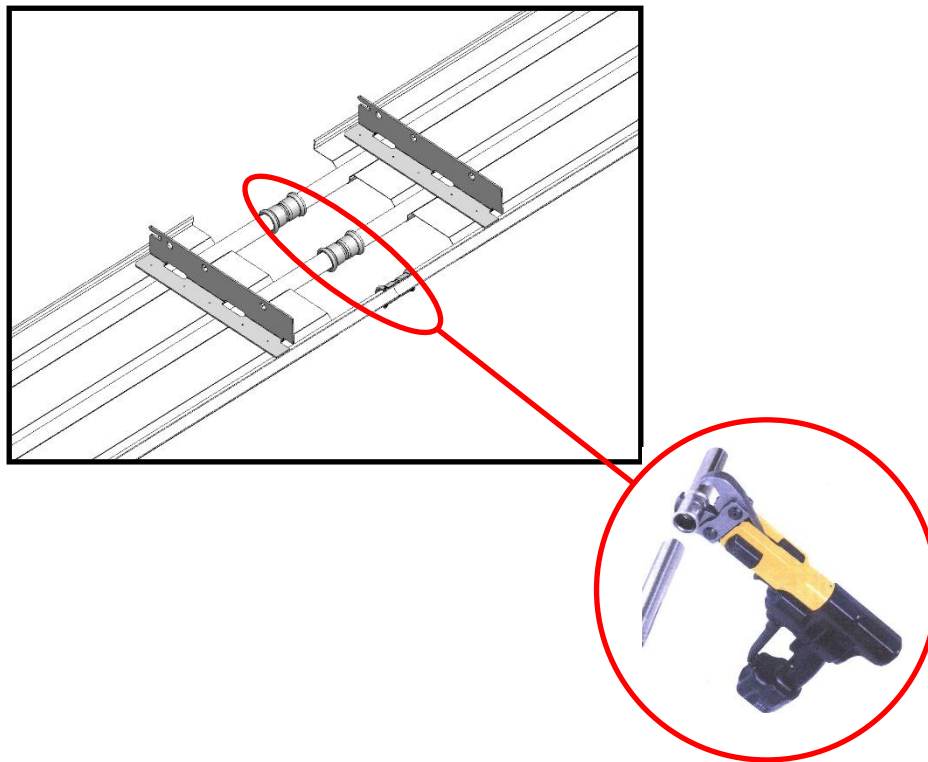
*Fig. 3.13 Insert the tubes in the sleeves till reach the bore*



*Fig. 3.13a Pinch the sleeve with the suitable tool*



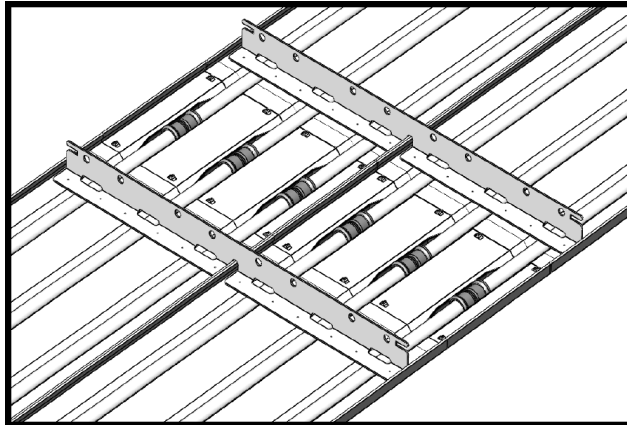
*Fig. 3.13b Insert the tubes of the next panels in the sleeves till reach the bore.*



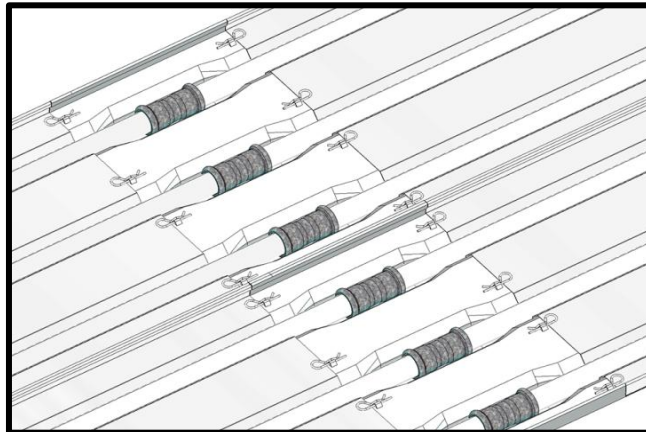
*Fig. 3.13c Pinch the sleeve with the suitable tool*

### 3.7 Assembly of joint covers

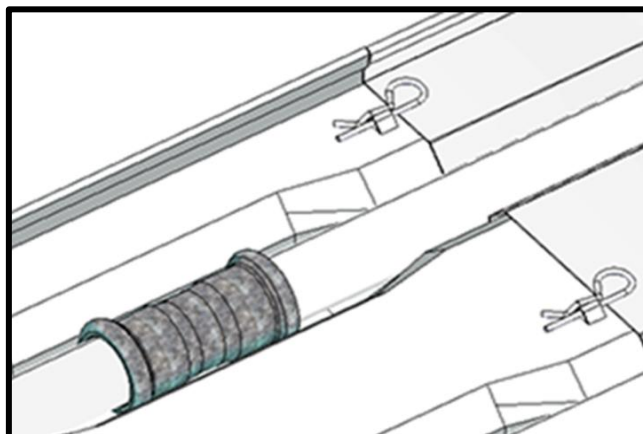
Place the joint covers and attach them with the hooks provided for this purpose.



*Fig. 3.14 Application of joint cover*



*Fig. 3.15 Fastening of joint cover*



*Fig. 3.16 Detail of fastening of joint cover*

### 3.8 Installation of the insulating mat on standard panels

Apply the side slats for the containment of the wool, inserting them from an end of the radiant panel.

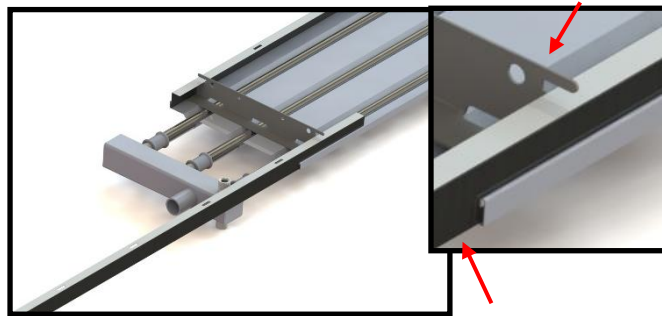


Fig. 3.17 Positioning of the side slats for the containment of the wool

After positioning the side slats, lay down the insulating mat with the paper side up, paying attention to do cuts near the angulars, where are the fixing points. Insert the mat under the side slats.

**Attention:** the insulating mats we provide have a width of 300, 600 and 900 mm. For panels of a 1200 mm width, use two mats of 600 mm.

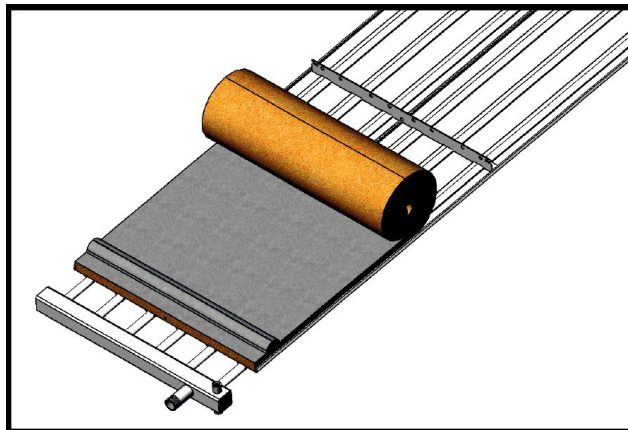


Fig. 3.18 Application of the insulating mat with the paper side up.

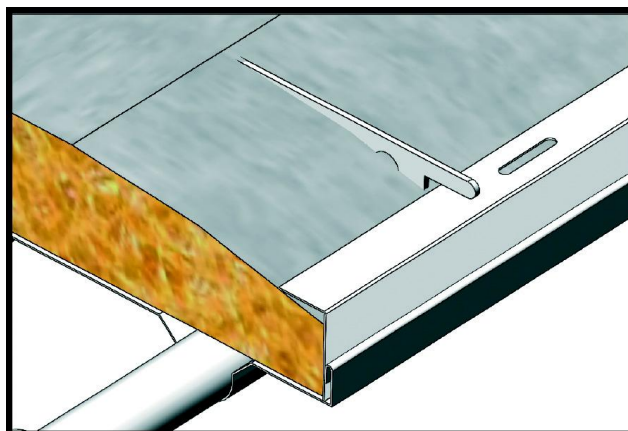
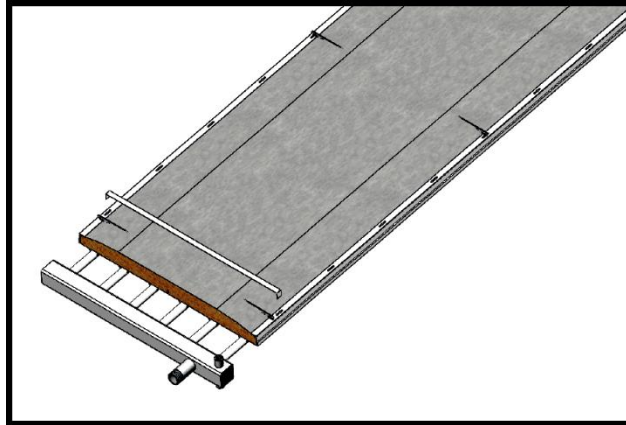
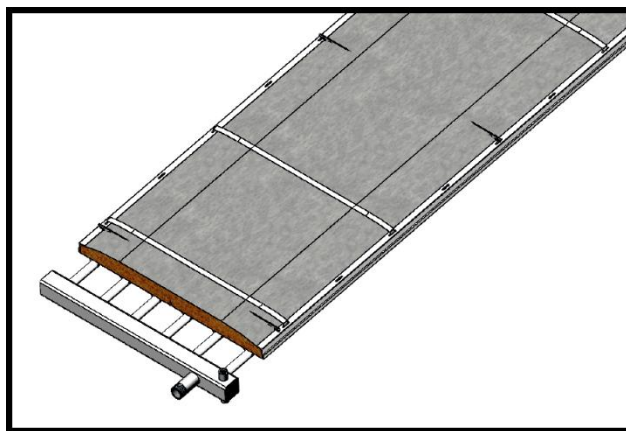


Fig. 3.19 Correct position of the insulating mat after cutting the mat nearby the fixing points and after inserting the mat under the side slats.

Finish the installation hooking the insulating straps (one per each meter).



*Fig. 3.20 Insertion of fiberglass holding straps*



*Fig. 3.21 Quantity and positioning of fiberglass holding straps*

**Radiant panel - length 2m:**

3 fiberglass holding straps are necessary;

- 1 at the beginning of the radiant panel
- 1 in the middle of the radiant panel
- 1 at the end of the radiant panel

**Radiant panel - length 4m:**

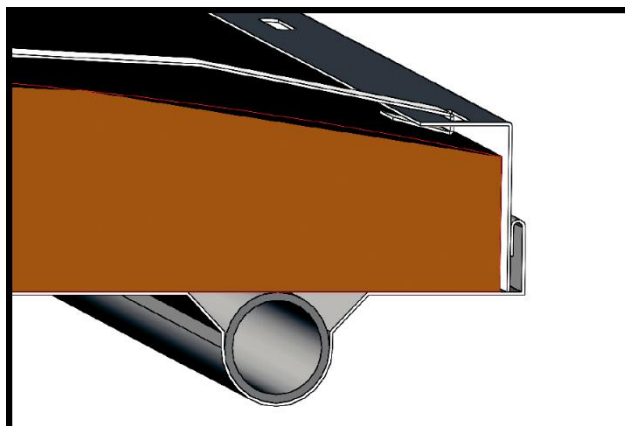
5 fiberglass holding straps are necessary;

- 1 at the beginning of the radiant panel
- 3 distributed in the middle (1 each meter)
- 1 at the end of the radiant panel

**Radiant panel - length 6m:**

7 fiberglass holding straps are necessary;

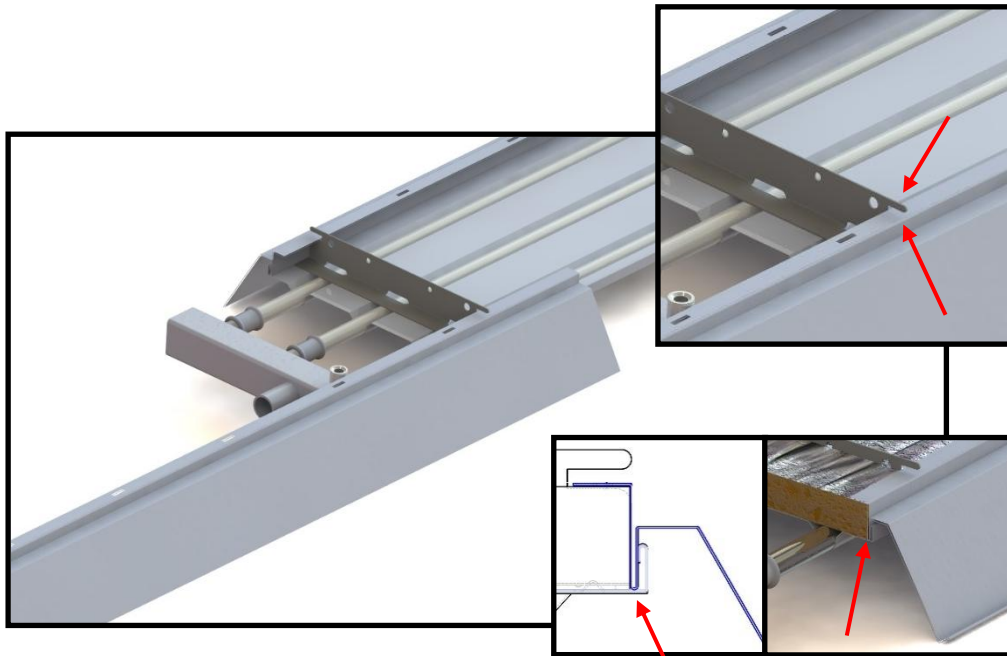
- 1 at the beginning of the radiant panel
- 5 distributed in the middle (1 each meter)
- 1 at the end of the radiant panel



*Fig. 3.22 Detail of fastening of fiberglass holding strap*

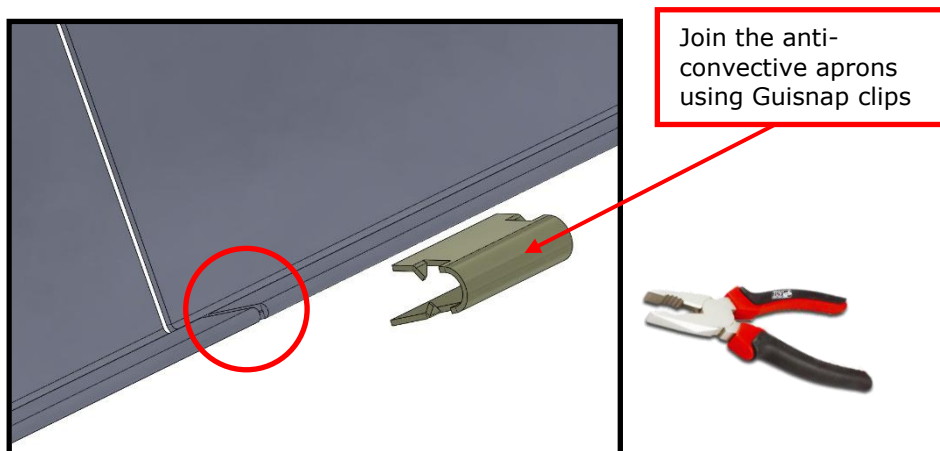
### 3.9 Installation of the insulating mat on panels with anti-convective aprons (optional)

Apply the lateral profiles to contain the wool, inserting them from one end of the radiant panel.

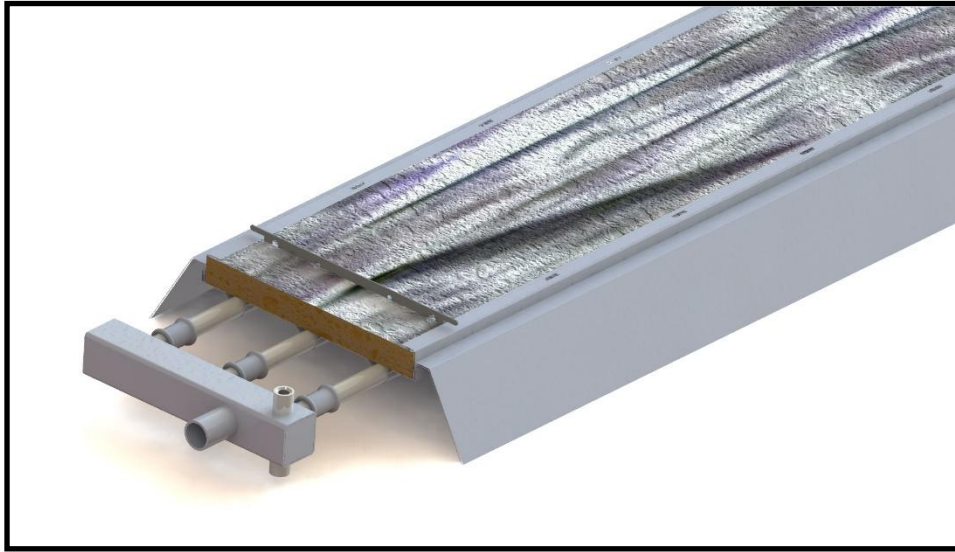


*Fig. 3.23 Insertion of the anti-convective aprons.*

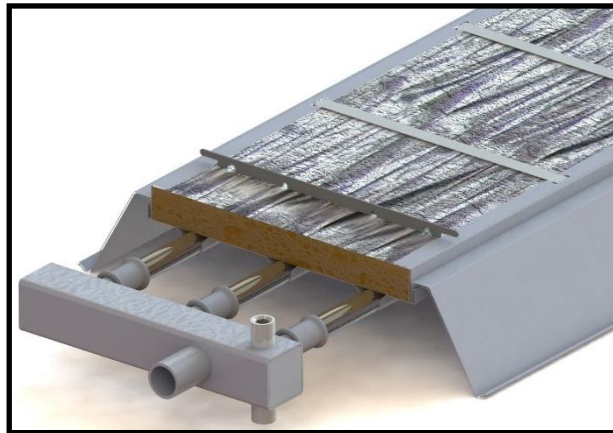
The insertion of the lateral anti-convective aprons must be done following the previous images.



*Fig. 3.24 Junction of anti-convective aprons.*



*Fig. 3.25 Apply the insulating mat with the paper layer upwards*



*Fig. 3.26 Fixing of the insulating mat with holding straps.*

### 3.10 Installation of cover for gyms (optional) on standard panels

After laying the insulating mat and the side holding profiles, insert the cover for gyms.

**Attention:** when using covers for gyms, the holding straps are not necessary.

These protections are installed over the radiant panels to avoid the formation of dust or the block of balls of different kind. The covers are especially useful for the installation in gyms, sport halls or dusty environments. There are two different kinds of covers, one for panels of 300, 600 and 900 mm width, the other for panel of 1200 mm.

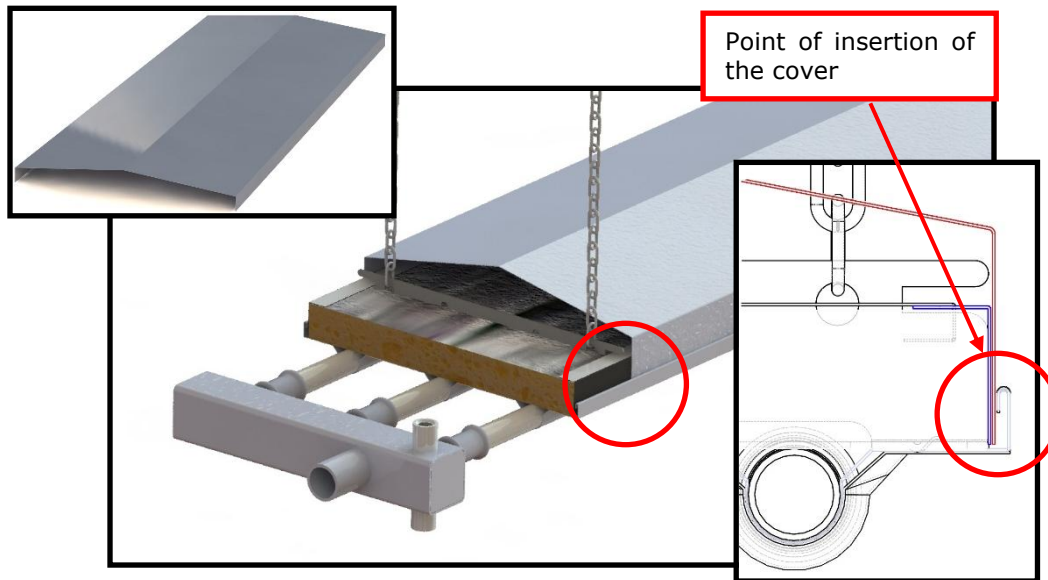


Fig.3.27 Covers for panels of 300, 600 and 900 mm.

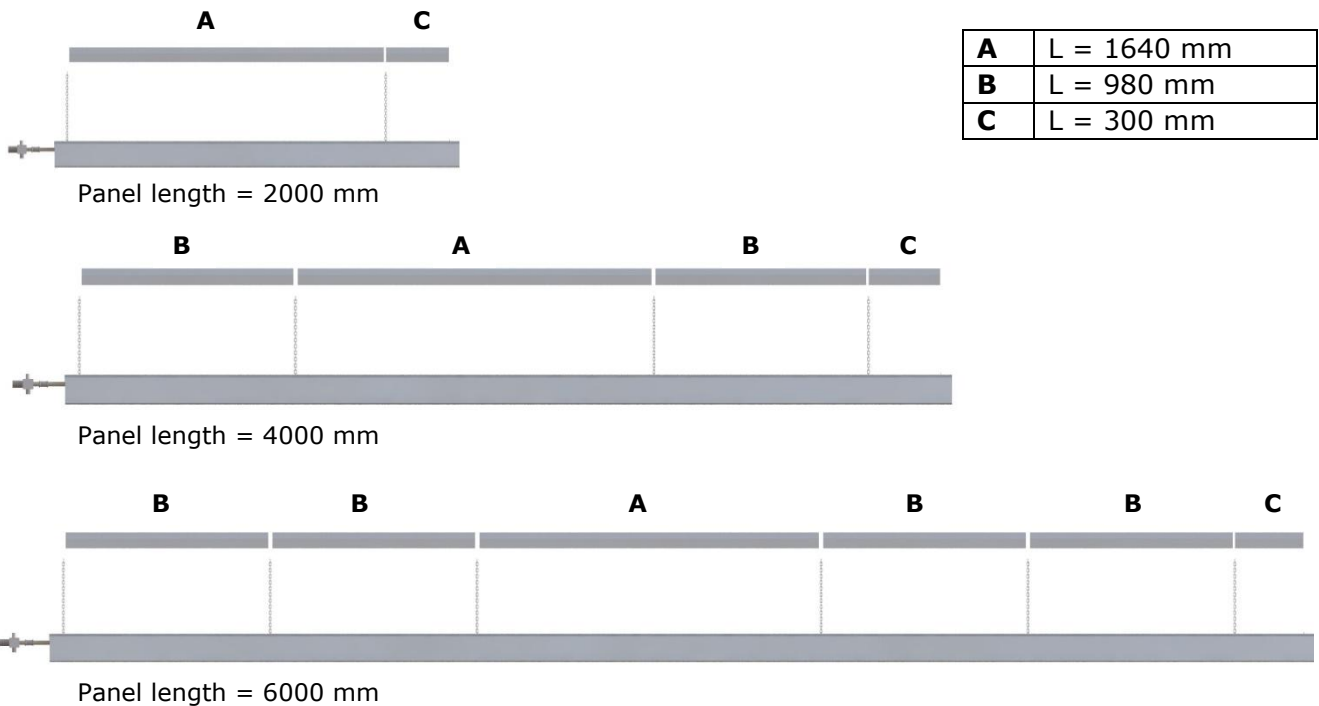


Fig. 3.28 Positioning of the covers

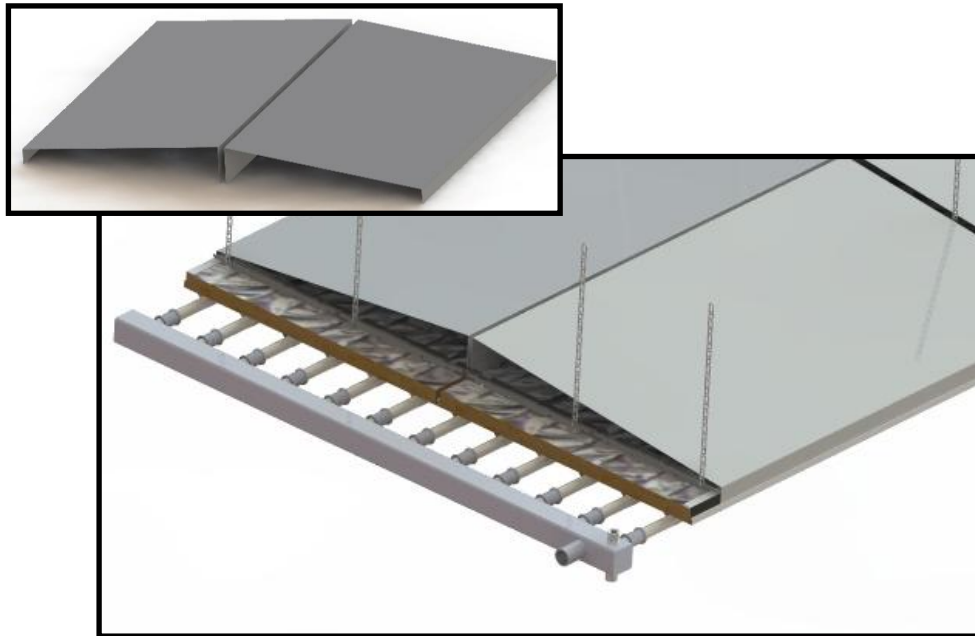


Fig. 3.29 Covers for panels of 1200 mm width.

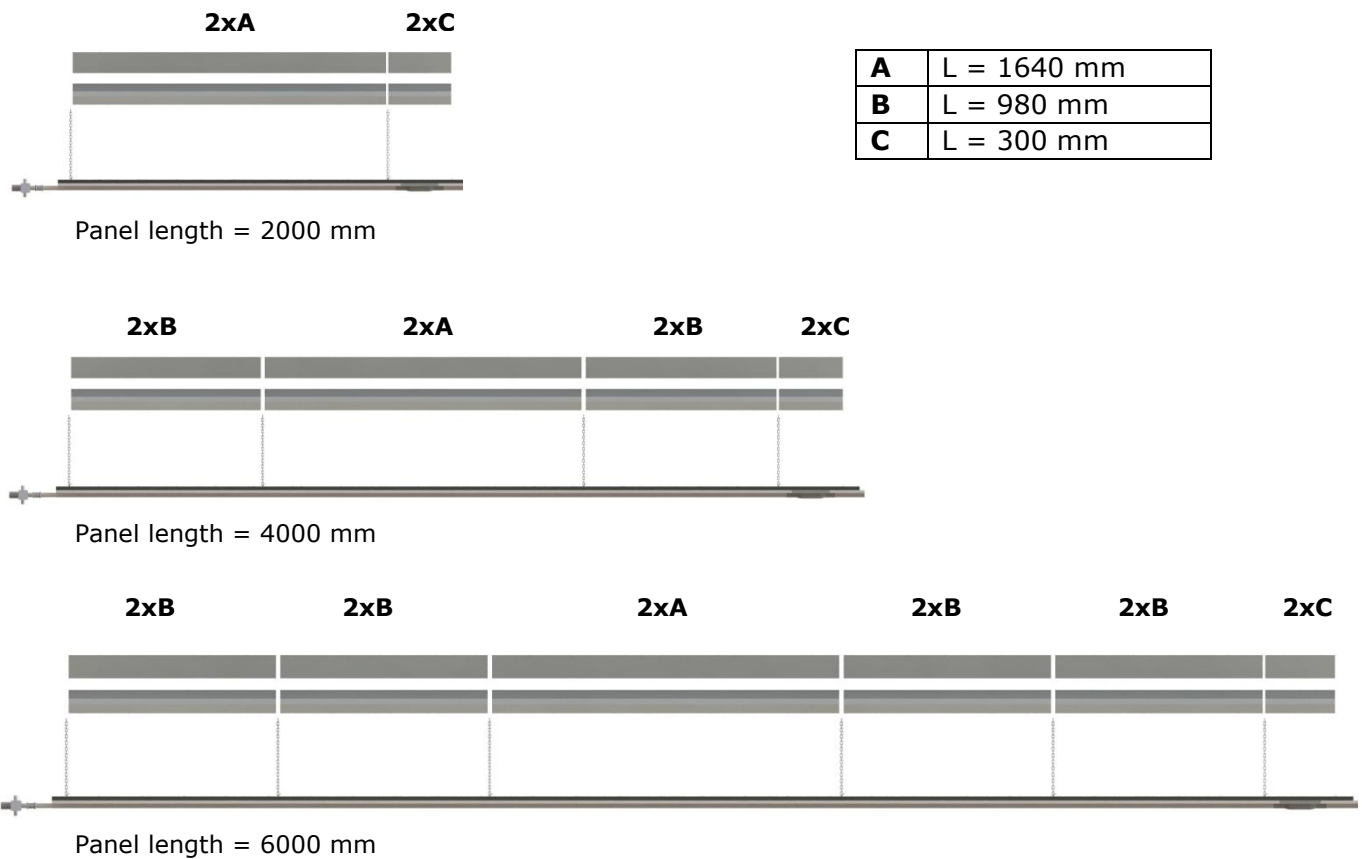


Fig. 3.30 Positioning of the covers

### 3.11 Installation of cover for gyms (optional) on panels with anti-convective aprons

After laying the insulating mat and the side holding profiles, insert the cover for gyms.

**Attention:** when using covers for gyms, the holding straps are not necessary.

These protections are installed over the radiant panels to avoid the formation of dust or the block of balls of different kind. The covers are especially useful for the installation in gyms, sport halls or dusty environments.

There are two different kinds of covers, one for panels of 300, 600 and 900 mm width, the other for panel of 1200 mm.

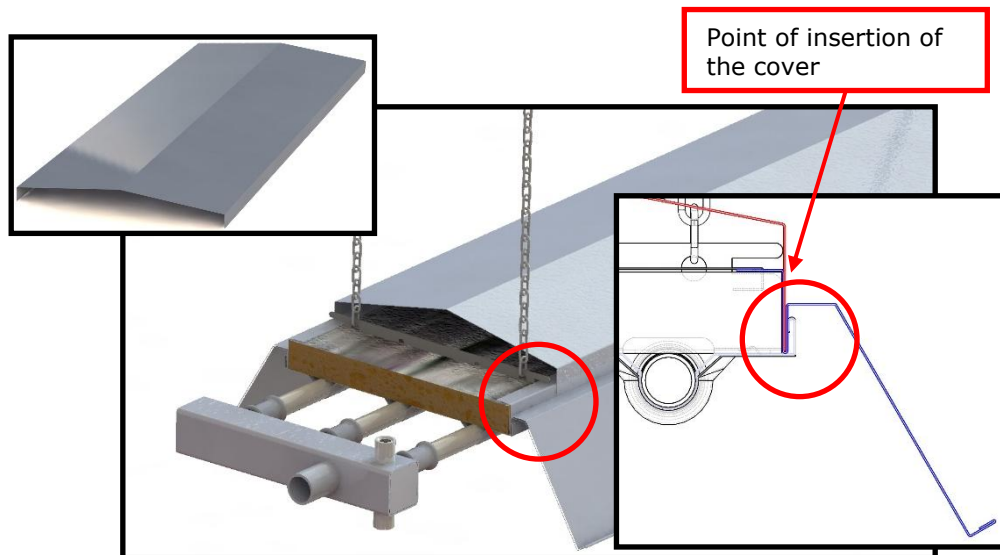


Fig. 3.31 Covers for panels of 300, 600 and 900 mm width, with anti-convective aprons.

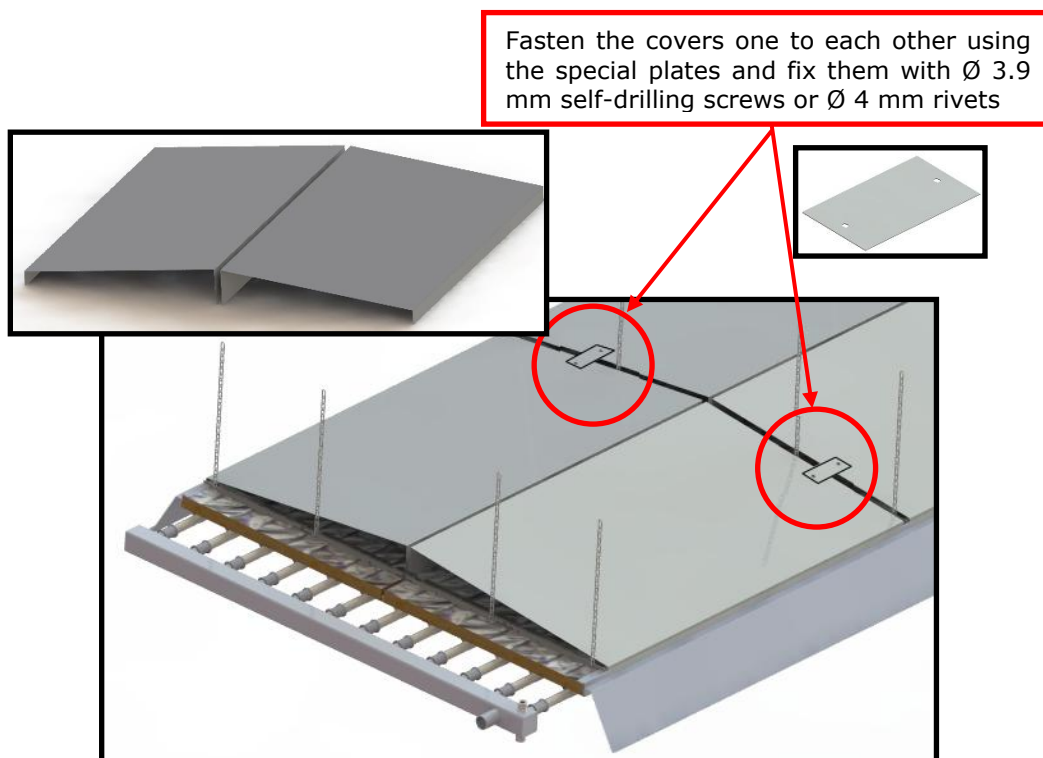


Fig. 3.32 Covers for panels of 1200 mm width.

## 3.12 Charging and discharging the system

Once the installation of the system is terminated and the discharges of the headers are closed with the suitable plugs, is it possible to proceed with the charging of the system with the thermal carrier (hot water).



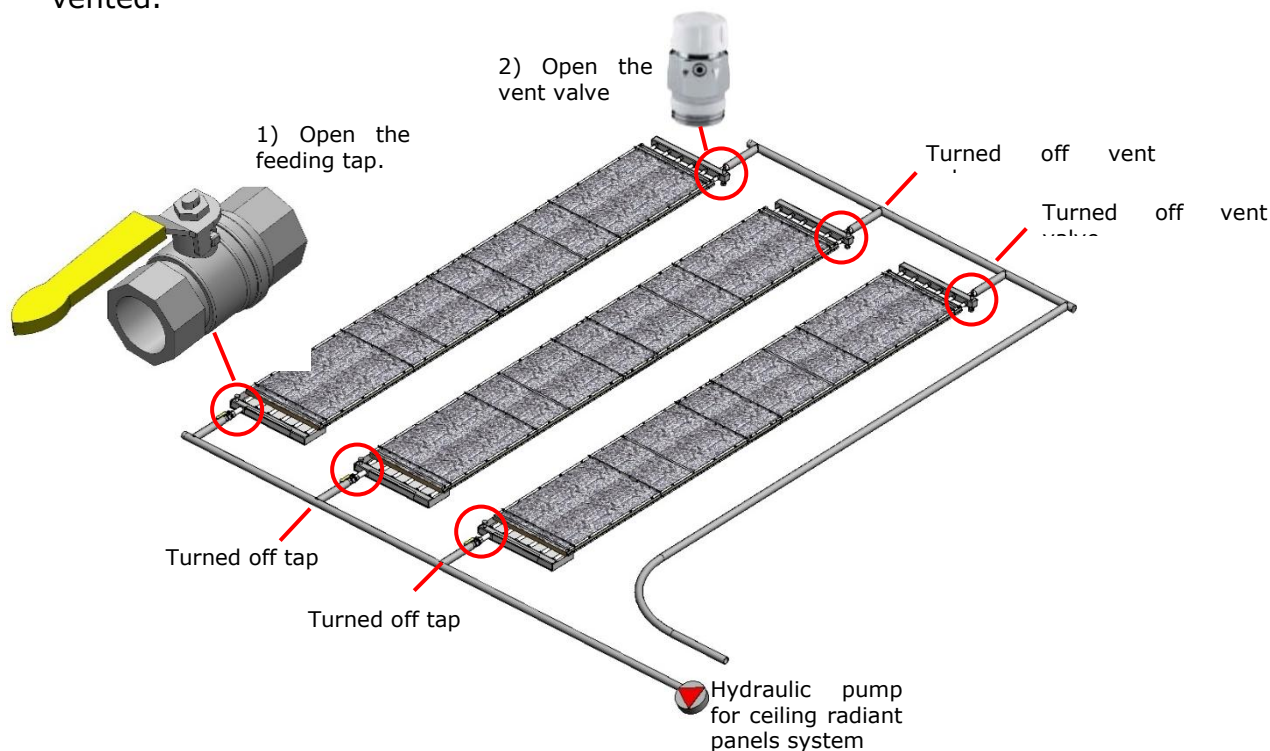
**ATTENTION:**

**Max. operating pressure is 6 bar.**

**For a correct operation, there must be no air into the system.**

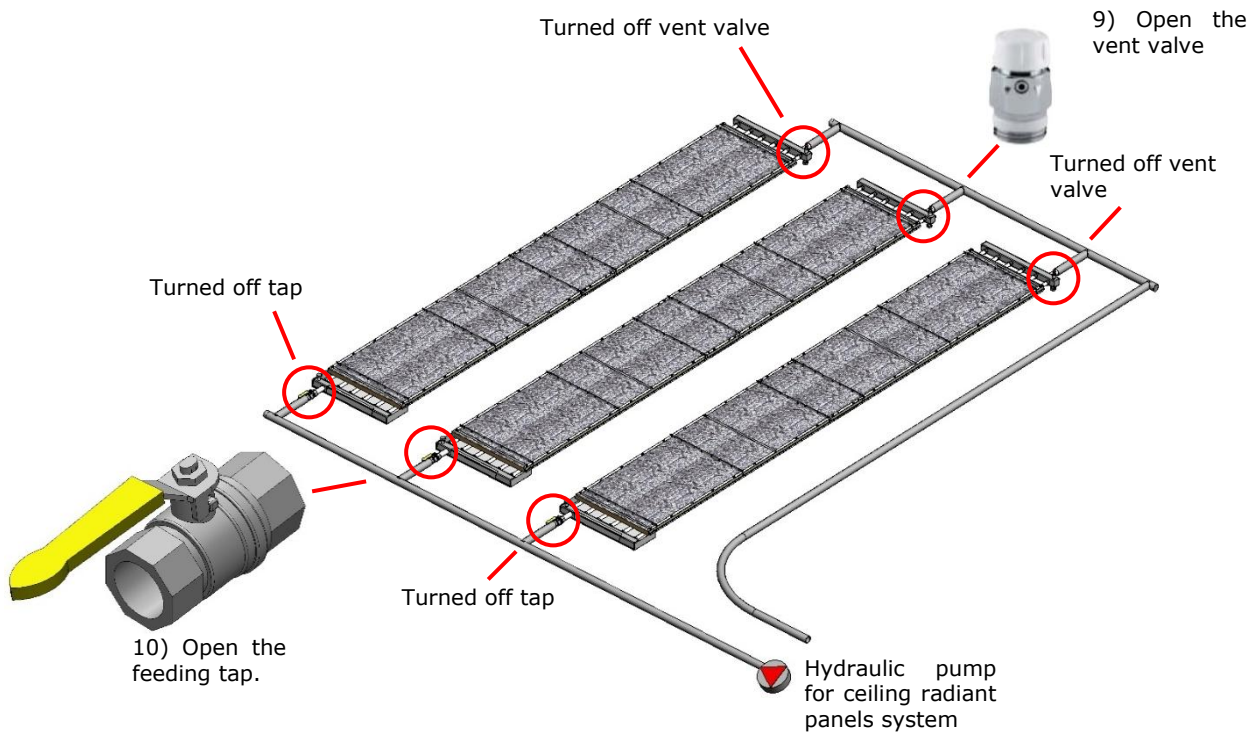
### 3.12.1 Instructions for charging and discharging the system.

- 1) Open the fluid feeding tap of the radiant panel, that is located on the most distant point respect to the hydraulic pump.
- 2) Open the vent valve of the selected radiant panel.
- 3) Turn on the hydraulic pump to fill and to vent the radiant panel.
- 4) Wait until the air has completely been vented from the valve.
- 5) When from the vent valve will come out water, the radiant panel can be considered vented.



- 6) After charging and vent the first radiant panel, turn off its vent valve.
- 7) After charging the first radiant panel, turn off its feeding tap.

- 8) Move to the previous radiant panel.
- 9) Open the vent valve.
- 10) Open the feeding tap of this last radiant panel to charge and discharge the panel.



- 11) Repeat points 6,7,8,9, 10 till reach the radiant panel that is closed to the hydraulic pump dedicated to the system.
- 12) At this point the system can be considered charged and vented and all the feeding taps of the single radiant panels can be turned on.

**The system is at capacity and is ready to work**

## 4 TECHNICAL SPECIFICATIONS

### The component of the ceiling radiant panels EUTERM are:

- Prepainted galvanized steel radiant panel 0.6 mm thick, cold profiled, of width 300, 600, 900 and 1200 mm and length of 2000, 4000, 6000 mm. The special semicircular shape with distance between centres 100 mm or 200 mm depending on the model, allows to place the tubes for the thermal carrier fluid.

#### **Radiant surface emissivity $\epsilon = 0.95$**

- Galvanized steel tubes with thickness 1.2 mm and external diameter of 22.0 mm directly placed in the semicircular seat of the radiant panels. The tubes are cold profiled, electronically welded, approved for **pressures until 6 bars** and a maximum carrier temperature of 120°C.
- galvanized steel angular for a quick fastening to the building structure.
- Headers made with galvanized steel squared tubes measuring 50 x 50 mm, with, on one side 1" threaded attachment (on request 1"1/4) for the connection to the heating circuit, on the other side, smooth cut pipes of a 22,0 mm diameter, fitted for the connection to the radiant panels by means of pressfittings. There is also a hole for air venting, and one which may be used for water discharge.
- Fibreglass insulating mat with aluminium foil on one side, thickness of 40 mm, with width 300, 600, 900 mm. The thermal characteristics are in according to DIN 52612.
- Side profile in prepainted galvanized steel containing the insulating mat (length 2050 mm) placed on the sides of the panel.
- Anti-convective side slats made of prepainted galvanized steel, for a higher emissivity towards the ground and for the reduction of convective motions of air towards the ceiling.
- Cover for gyms made of galvanized steel to avoid the storing of dust and to prevent balls to get stuck on top of the panels.
- Transversal straps in prepainted galvanized steel containing the insulating mat (one each meter).
- Prepainted galvanized steel joint covers to hide the connections between ceiling radiant panels.

## 5 DECLARATION OF CONFORMITY



### DICHIARAZIONE DI CONFORMITA' *Declaration of Conformity*



Il produttore / *the producer:*



con sede in / *with location in:* Via Fossaluzza, 12 - 33074 FONTANAFREDDA (PN) - ITALY

in qualità di Produttore dei pannelli radianti modello  
*in quality of producer of radiant panels model:*

**EUTERM**

**AVH 300 ; AVH 600 ; AVH 900 ; AVH 1200 ;**

dichiara che i suddetti prodotti sono stati testati presso l'istituto autorizzato  
*declare that the above mentioned products are be tested by the authorized institute*

**HLK Stuttgart - Institut für Gebäudeenergetik  
Universität Stuttgart**

secondo le norme europee / *in according with the European conformities*

per il riscaldamento / *for heating*

**EN 14037-1: 2003** Ceiling mounted radiant panels

e sono conformi alle richieste essenziali del Regolamento per i prodotti da costruzione  
*and are comply with the essential requirements of Construction Products Regulation (CPR)*

**(EU) 305/2011 'CPR'**

Luogo e data / *Place and date*  
Fontanafredda, li 05/12/18

CARLIEUKLIMA Srl  
l'amministratore delegato  
*the managing director*

*Carlo Alberto*  
Via Fossaluzza, 12 - Z.I. CASU1  
33074 FONTANAFREDDA (PN)  
Part. IVA 01265170934  
Cod. Fisc. 03418170934

Firma e timbro / *signature and stamp*





## **CARLIEUKLIMA Srl**

Via Fossaluzza, 12  
33074 Fontanafredda (PN)  
ITALY

Tel. (+39) 0434 599311

Fax (+39) 0434 599320

[info@carlieuklima.it](mailto:info@carlieuklima.it)

[www.carlieuklima.it](http://www.carlieuklima.it)

